

DATA SHEET

CSE MIX G60 1M Pump Station



Main Features

Application	Providing circulation and mixing of a heating circuit or solid fuel fired source circuit. Switching of the circulation pump and control of the mixing valve is realized from an external controller.
Description	Consist of Grundfos UPM3 AUTO 25-60 pump, LK 840 3-way mixing valve w. AVC actuator, insulation.
Working fluid	Water; water-glycol mixture (max. 1:1) or water-glycerine mixture (max. 2:1).
Installation	Flow pipe to heating circuit / on solid fuel boiler return pipe, min. pipe centre distance from wall is 100 mm.
Code	19110

Data for CSE MIX G60 1F Pump Station

Fluid working temperature	5–95 °C
Max. working pressure	10 bar
Min. working pressure	0.5 bar
Ambient temperature	5–40 °C
Max. relative humidity	80 % non condensing
Pump station power supply	230 V, 50 Hz
Pump station max. power input	42 W
Min./max. current to pump	0.04/0.44 A
Actuator torque	5 Nm
Actuator angle of rotation	90°
Actuator shift time	120 s
Actuator control	3-point
Mixing valve Kvs	6.3 m ³ /h
Max. pressure difference	5 mH ₂ O (at mixing valve inlets)
Leak rate	< 1 % Kvs at 5 mH ₂ O pressure difference (at mixing valve inlets)
Insulation material	EPP RG 60 g/l
Overall dimensions	305 x 140 x 220 mm
Total weight	3.9 kg
Connections	2 x G 1" M, 1 x G 1" F

Pump Performance Curves

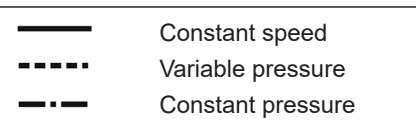
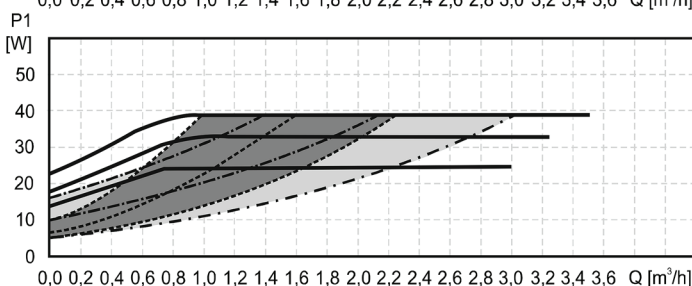
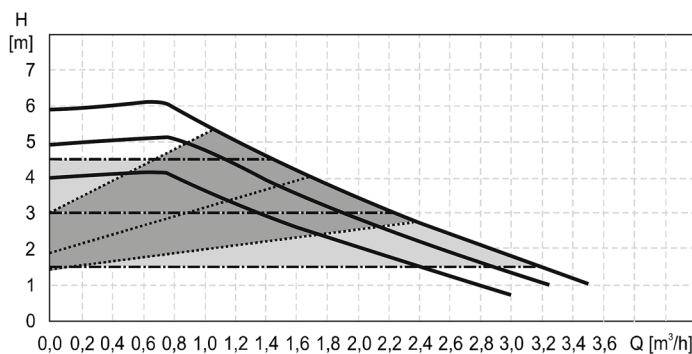

Selected profile signaling*



curve 1 (4 m)



curve 2 (5 m)



curve 3 (6 m)

* example for proportional pressure mode, for more see manual

Curve	Max. H (upper graph)	Max. P ₁ (lower graph)
1	4 m	25 W
2	5 m	33 W
3	6 m	39 W

for constant speed mode

DATA SHEET

CSE MIX G60 1M Pump Station

Pump Station Pressure Drop

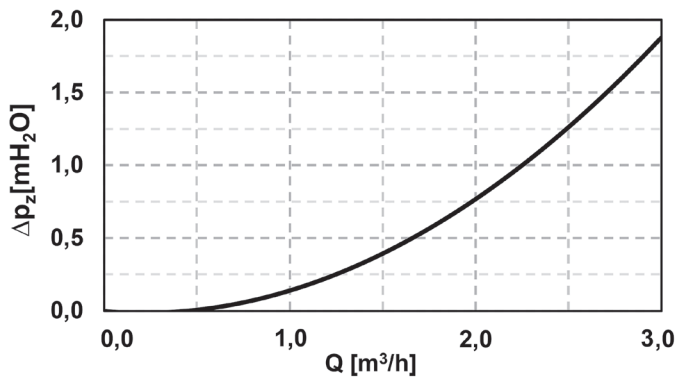

Pressure drop in straight direction.

Pump Electrical Wiring

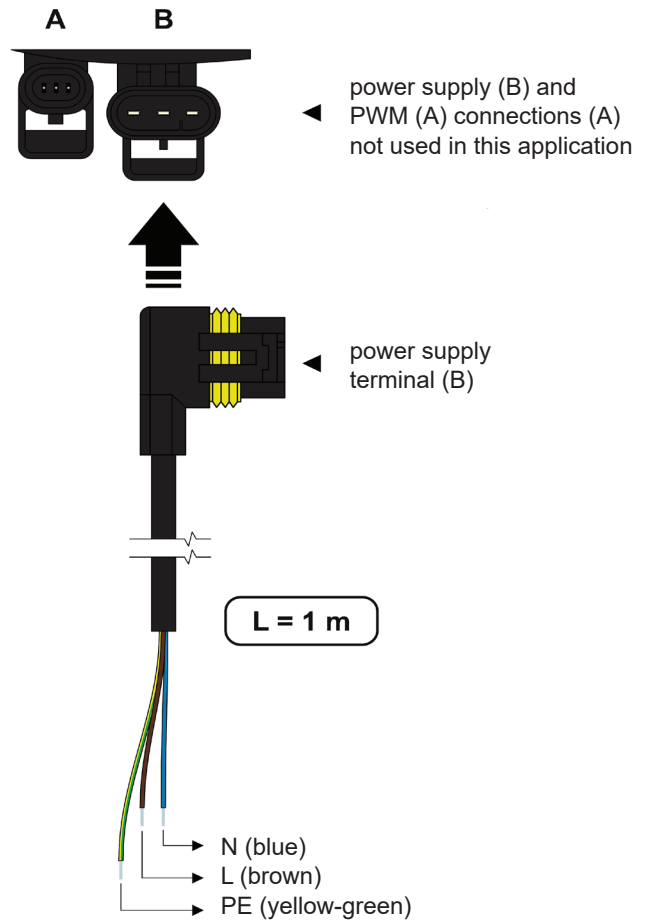

Actuator electrical wiring

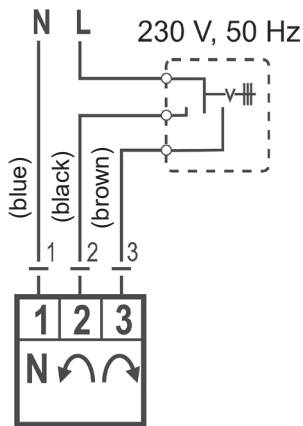

Example of possible connection I

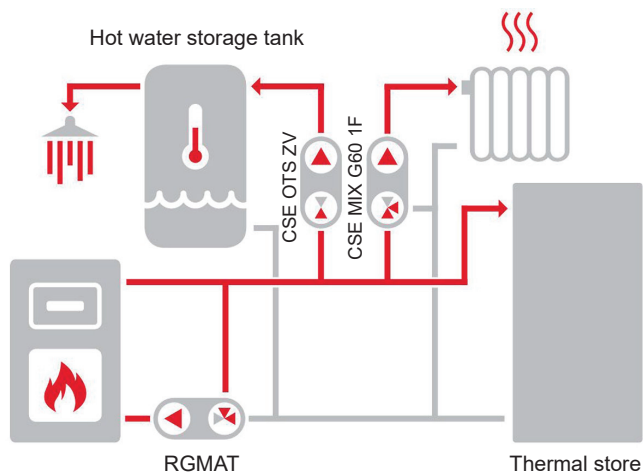

The diagram shows a typical connection of a solid fuel boiler (with the recommended RGMAT pump station – not included in supply), thermal store and heating circuit. If the boiler is used also for hot water heating, it is recommended to install a CSE OTS ZV W pump station (not included in supply).

Example of possible connection II

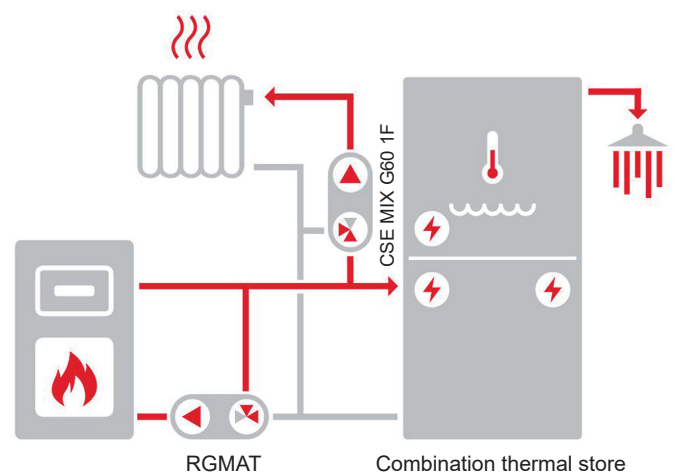

The diagram shows a typical connection of a solid fuel boiler (with the recommended RGMAT pump station – not included in supply), combination thermal store and heating circuit.