

# Installation and Operation Instructions

## STORAGE WATER HEATERS RGC 300/SOL1 STDC and RGC 300/SOL2 SRS3



Date of Manufacture: .....

Serial number: .....

Checked by: .....



EN  
v. 1.2



# CONTENTS

<b>1 Description .....</b>	<b>3</b>
1.1 Models .....	3
1.2 Tank protection .....	3
1.3 Thermal insulation .....	3
1.4 Connection points on the tank .....	3
1.5 Packing .....	3
<b>2 General Information .....</b>	<b>3</b>
<b>3 Technical Data and Dimensions .....</b>	<b>4</b>
<b>4 Operation .....</b>	<b>5</b>
<b>5 Examples of Assigning Connection Points .....</b>	<b>5</b>
<b>6 Installation and Commissioning .....</b>	<b>7</b>
6.1 Connection to a solar system .....	7
6.2 Heating rod installation .....	7
6.3 Connection to water mains .....	7
6.4 Electronic anode rod installation .....	7
6.5 Commissioning .....	8
<b>7 Maintenance, Replacement of Magnesium Anode Bar .....</b>	<b>8</b>
<b>8 Disposal .....</b>	<b>8</b>
<b>9 Warranty .....</b>	<b>8</b>

# 1 - Description

RGC 300/SOL1 STDC and RGC 300/SOL2 SRS3 Storage Water Heaters are intended for domestic hot water (DHW) accumulation. Water is heated via a heat exchanger (a heating coil) placed inside that can be connected to a heat source (e.g. a boiler). How fast DHW is being heated to the desired temperature depends first of all on the temperature of the heat carrying fluid entering the heat exchanger. The hotter the incoming heat carrier, the faster the tank heats up. Should the heat exchanger show insufficient performance in some applications, an electric heating element can be installed into the tank. In order to reach proper working of the tank, it is necessary to design optimum hydraulics of the whole system, i.e. position of circulation pumps for sources and heating circuits, valves, non-return valves etc.

In order to reduce heat loss, the tank is insulated with soft polyurethane foam.

## 1.1 - Models

These Storage Water Heaters are supplied in 300l capacity either with a single-pipe pump station and STDC solar controller, or a twin-pipe pump station and SRS3 solar controller.

## 1.2 - Tank protection

The tank is made of steel, treated from outside with ecologic powder coating. For its anti-corrosion properties the inner surface is completely enameled which ensures a long service life in combination with a magnesium anode rod. The condition of the magnesium anode rod shall be checked at regular intervals - see section 7. Maintenance, Replacement of Magnesium Anode Bar. This tank can be fitted with an electronic anode rod that requires no maintenance/replacement if checked regularly.

## 1.3 - Thermal insulation

The tank is insulated with ecologic polyurethane foam, 75 mm thick, that reduces heat loss to minimum.

## 1.4 - Connection points on the tank

2 side ports with G 1" F for solar circuit

2 side ports with G 1" F for cold water inlet and hot water outlet

2 sheaths for temperature sensors,  $\varnothing$  17x2

1 side port with G 3/4" F for circulation

1 top port G 5/4" for magnesium anode rod

1 side port with G 6/4" F for el. heating element

## 1.5 - Packing

Tanks are delivered standing, each screwed to its pallet, packed in bubble wrap. They shall not be transported/stored in a horizontal position..

# 2 - General Information

The appliance shall be installed by a qualified person according to valid rules and Manufacturer's Instructions.

This Owners Manual is an integral and important part of the product and must be handed over to the User. Read carefully the instructions in this Manual as they contain important information concerning safety, installation, operation and maintenance. Keep this Manual for later reference.

Using the tank for other purposes than stated above is forbidden and the manufacturer accepts no responsibility for damage caused by improper or wrong use.

### 3 - Technical Data and Dimensions

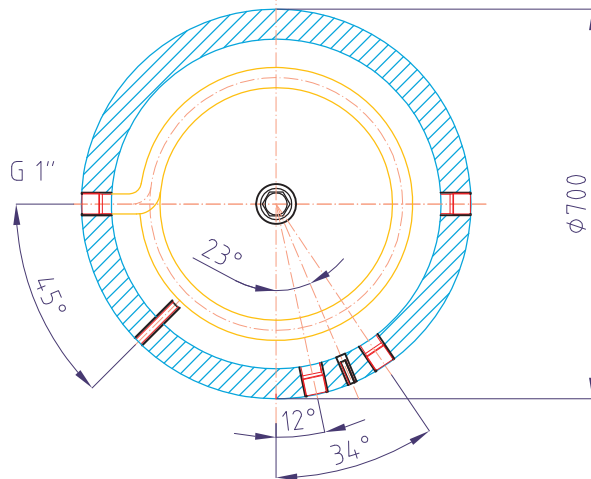
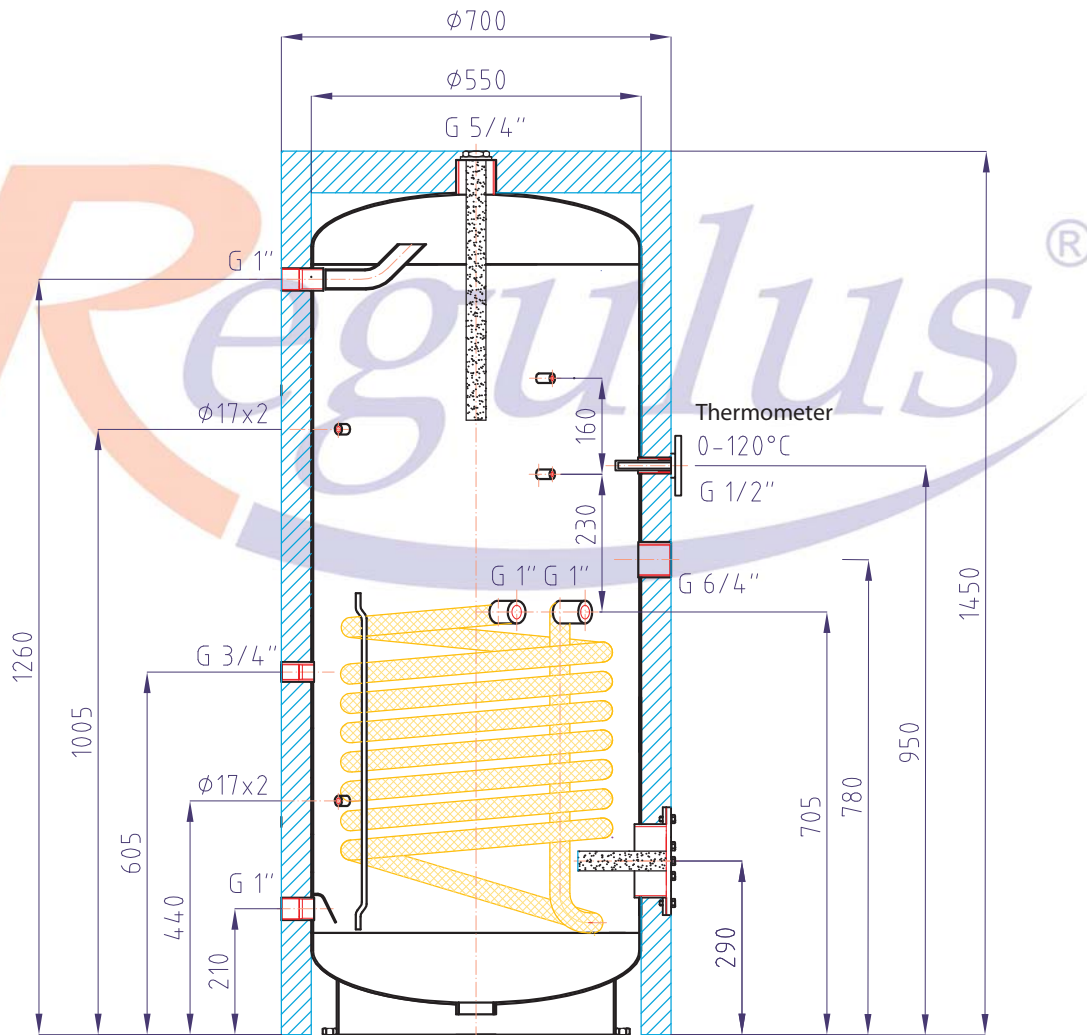

Total tank volume: .....	300 l
Lower heating coil volume: .....	8.6 l
Lower heating coil surface area: .....	1.4 m <sup>2</sup>
Max. working temperature - tank: .....	100 °C
Max. working temperature - heating coil: .....	100 °C
Max. working pressure - tank: .....	6 bar
Max. working pressure - heating coil: .....	10 bar
DHW heating at $\Delta t=35\text{ °C}$ (80/60 - 10/45) - lower coil: .....	1190 l/h (48.5 kW)
Empty weight: .....	122 kg

## 4 - Operation

This tank is designed for operation in closed pressure circuits. Hot water is heated in the integrated hot-water heat exchanger (heating coil) inside the tank from solar collectors. An electric heating rod can be installed into the tank for DHW backup heating.

Hot water temperature should be set to 60-65°C. This temperature guarantees the best operation and at the same time, it prevents formation of Legionella bacteria.

## 5 - Examples of Assigning Connection Points

### Example I.

RGC 300/SOL1 STDC

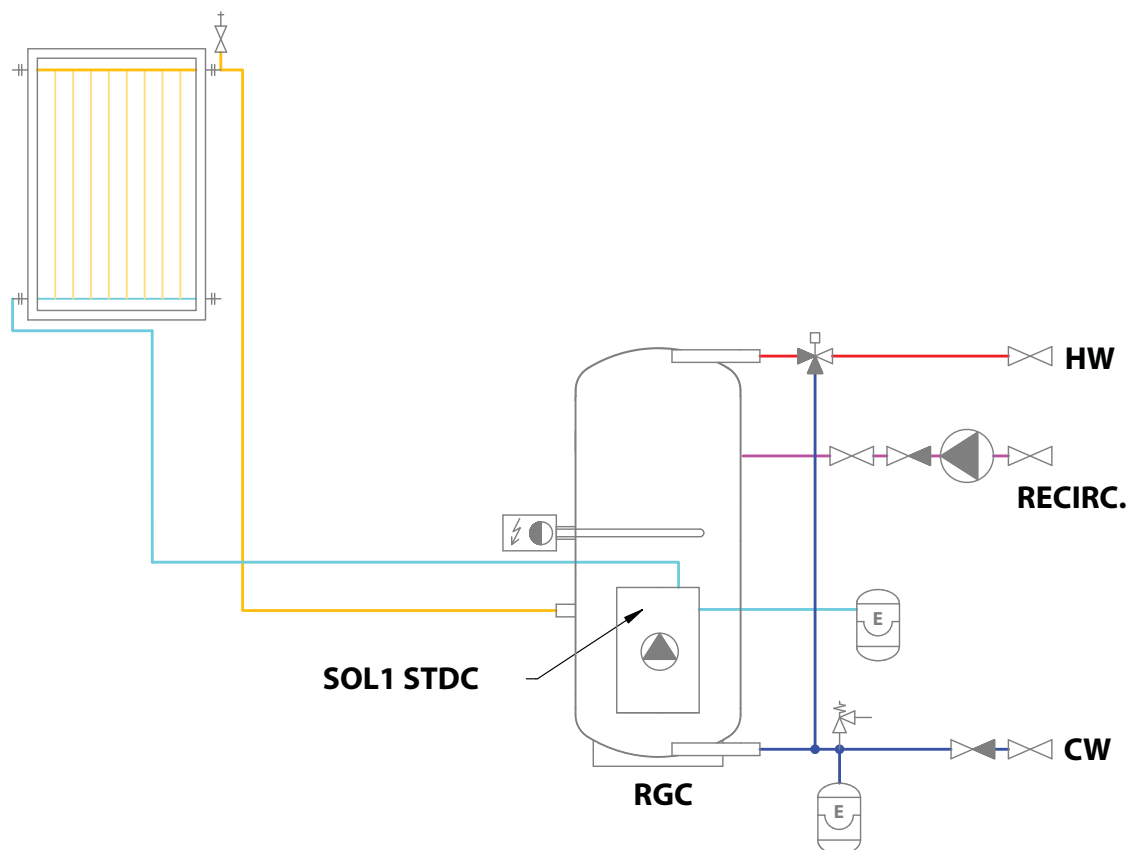

**Example II.**  
RGC 300/SOL2 SRS3

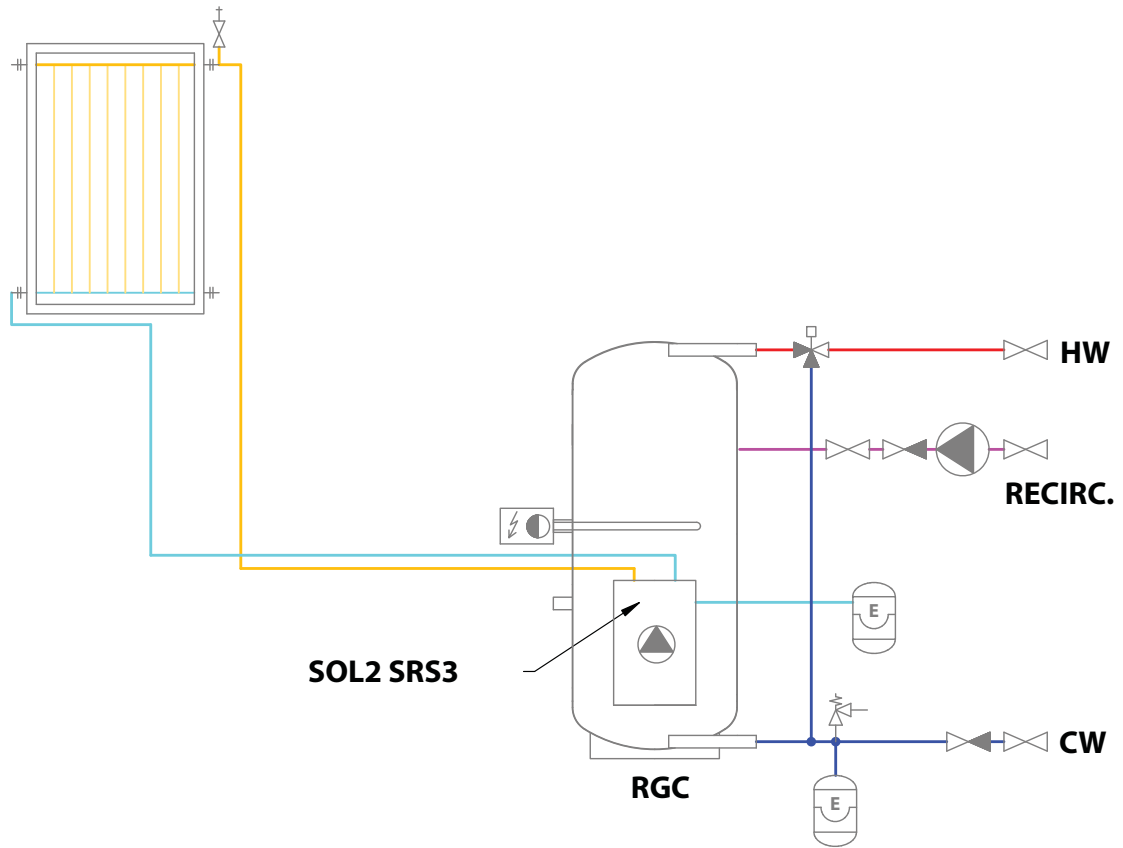

Table of limit values for total dissolved solids in hot water

Description	pH	Total dissolved solids (TDS)	Ca	Chlorides	Mg	Na	Fe
max. value	6.5 - 9.5	600 mg/l	40 mg/l	100 mg/l	20 mg/l	200 mg/l	0.2 mg/l

# 6 - Installation and Commissioning

Installation must meet valid rules and may be done only by qualified staff. The tank shall be placed on the floor, as close to the heat source as possible..

**Warning: Defects caused by improper installation, use or handling are not covered by warranty.**

## 6.1 - Connection to a solar system

The inlet for hot heat-carrying liquid coming from the solar system shall be connected to the left G1" port of solar coil and the right G 1" port connects to the return piping to the solar system. Insulate all the piping between the tank and the solar system.

## 6.2 - Heating element installation

The G 6/4" side sleeve is designed to accommodate an electric heating rod. Heating rods of output up to 6 kW can be used (depending on the tank diameter and rod length), connected either directly to the mains (thermostat-equipped rods), or to a heating system controller. The installation may be done by qualified staff only.

**Warning: Electric heating elements shall be protected by a safety thermostat.**

## 6.3 - Connection to water mains

DHW piping shall be done according to valid rules. G 1" threaded couplers are used to connect the tank to a cold water inlet and hot water outlet . A 6 bar safety valve shall be installed at the cold water inlet. Installation of a reducing valve to the tank inlet is recommended. If the pressure from water mains exceeds 6 bar, a reducing valve is necessary. In order to prevent water loss, an expansion tank should be installed at the cold water inlet as well (min. volume of 12 l).

Should the water be too hard, install a water softener before the tank. In case the water contains mechanical impurities, install a strainer.

Should the water be too hard, install a water softener before the tank. In case the water contains mechanical impurities, install a strainer.

Install a drain valve to the lowest point of the tank.

Complete DHW piping shall be properly insulated.

## 6.4 - Electronic anode rod installation

A so called electronic anode rod can be used instead of the magnesium one. Its principle advantage is that its proper function is signaled by an indication lamp while a magnesium anode rod needs to be taken out for check. In such a case, just visual check of the indication lamp is sufficient.

Please use a G 5/4" to G 1/2" reducing coupler when installing an electronic anode. A space of circa 0.5m is needed between the tank top and ceiling to install the electronic anode rod (replace the magnesium one). In order to protect the tank properly and meet its warranty conditions, use the electronic anode rod shown in the table below.

### Kit for RGC storage water heaters

Code	Anode rod length [mm]	For storage water heaters
9177	500 (350/150)	RGC 300/SOL

## 6.5 - Commissioning

Fill the heating circuits with the appropriate fluids and air-bleed the entire system. Check all connections for leaks and verify the system pressure.

The quality of top-up and heating water is set by ČSN 07 7401:1992. **Hot water quality must meet the conditions shown in the Table of limit values for total dissolved solids in hot water, page 6 of this Manual.**

Fill the heating circuits with the appropriate fluids and air-bleed the entire system. Check all connections for leaks and verify the system pressure. Set the heating controller in compliance with the documentation and manufacturer's recommendations. Check regularly a proper function of all control and adjusting elements.

## 7 - Maintenance, Replacement of Magnesium Anode Rod

If the tank is fitted with a heating element, disconnect it from the mains first. Clean the exterior of the tank with a soft cloth and a mild detergent. Never use abrasive cleaners or solvents.

Check all connections for leaks.

The tanks are equipped with an anti-corrosion sacrifice magnesium anode rod. The anode rod shall be checked within 12 months after commissioning and subsequently always not later than 12 months after the last check. In locations where water contains more ferrites or calcites, it is recommended to check the anode every 6 months. If more than 1/3 of its total volume is consumed, the anode shall be replaced with a new one. Disregarded of its state, the anode rod shall be replaced with a new one within 24 months from commissioning. In case an electronic anode is used, the above described procedures are not necessary. Then only a visual check of the indication lamp is necessary every 3 months. Proper working of the Electronic Anode is described in its User's Manual.

If damage to a tank occurs due to a neglected substitution of a magnesium anode rod or a non-working electronic anode, the warranty cannot be claimed.

## 8 - Disposal

Packing shall be disposed of in compliance with the valid rules. When the product reaches the end of its life, it shall not be disposed of as household waste. It shall be dropped off at a Local Waste Recycling Center. Insulation shall be recycled as plastic and the steel vessel as scrap iron.

## 9 - Warranty

This product is covered by warranty according to the conditions described in this Manual and according to the Warranty Certificate. A Warranty Certificate is an integral part of the supply. Tank transport or storing in a horizontal position is considered a warranty violation!

05/2012



**REGULUS spol. s r.o.**

Do Koutů 1897/3

143 00 Praha 4

<http://www.regulus.eu>

E-mail: [sales@regulus.cz](mailto:sales@regulus.cz)