



[www.regulus.eu](http://www.regulus.eu)



CSE MIX-BP G75 5/4F

Installation and Operation Manual  
**CSE MIX-BP G75 5/4F PUMP STATION**  
with mixing valve

**EN**

**CSE MIX-BP G75 5/4F**

# 1. Introduction

CSE MIX-BP G75 5/4 F pump station is designed to be installed in heating circuits where it provides heating water mixing and circulation through the circuit. Its typical application is in mixed heating circuits in buildings where it provides circulation and mixing of heating water to a desired temperature. It can be also used for solid-fuel boiler circuits where it provides circulation and mixing to a min. temperature of return water to the boiler as a protection against low-temperature corrosion. The circulation pump is switched from an external controller by 230VAC output. The controller is not included in supply.

## 2. Description of the pump station

| Základní charakteristika |   |
|--------------------------|---|
| Application              | Providing circulation and mixing of a heating circuit or solid-fuel fired heat source circuit. Switching of the circulation pump and control of the mixing valve is performed by an external controller that is not included in supply. When necessary, an actuator can be purchased for the mixing valve, for codes see the Catalogue. |
| Description              | Consist of UPM3 Flex AS 25-75 130 pump, LK 840 3-way mixing valve, insulation   |
| Working fluid            | water, water-glycol mixture (max. 1:1) or water-glycerine mixture (max. 2:1)  |
| Installation             | Flow pipe to heating circuit / solid fuel boiler return pipe, min. pipe centre distance from wall is 100 mm.  |
| <b>Code</b>              | <b>18753</b>  |

| Technical data of CSE MIX-BP G75 5/4F pump station |   |
|--|---|
| Fluid working temperature                          | 5 - 95 °C   |
| Max. working pressure                              | 10 bar  |
| Min. working pressure                              | 0.5 bar   |
| Ambient temperature                                | 5 - 40 °C   |
| Max. rel. humidity                                 | 80 % non condensing                                 |
| Insulation material                                | EPP RG 60 g/l                                       |
| Mixing valve Kvs                                   | 16 m <sup>3</sup> /h                                |
| Mixing valve leak rate                             | < 1% Kvs at 5 mH <sub>2</sub> O pressure difference |
| Overall dimensions                                 | 325 x 140 x 160 mm                                  |
| Total weight                                       | 4 kg  |
| Connections  | 3 x G 5/4" F  |

### 3. Pump Station Connection

The diagram shows a typical connection of a solid fuel boiler, thermal store and heating circuit. If there is also the indicated hot water circuit, install the CSE OTS ZV pump station (not included in the supply).

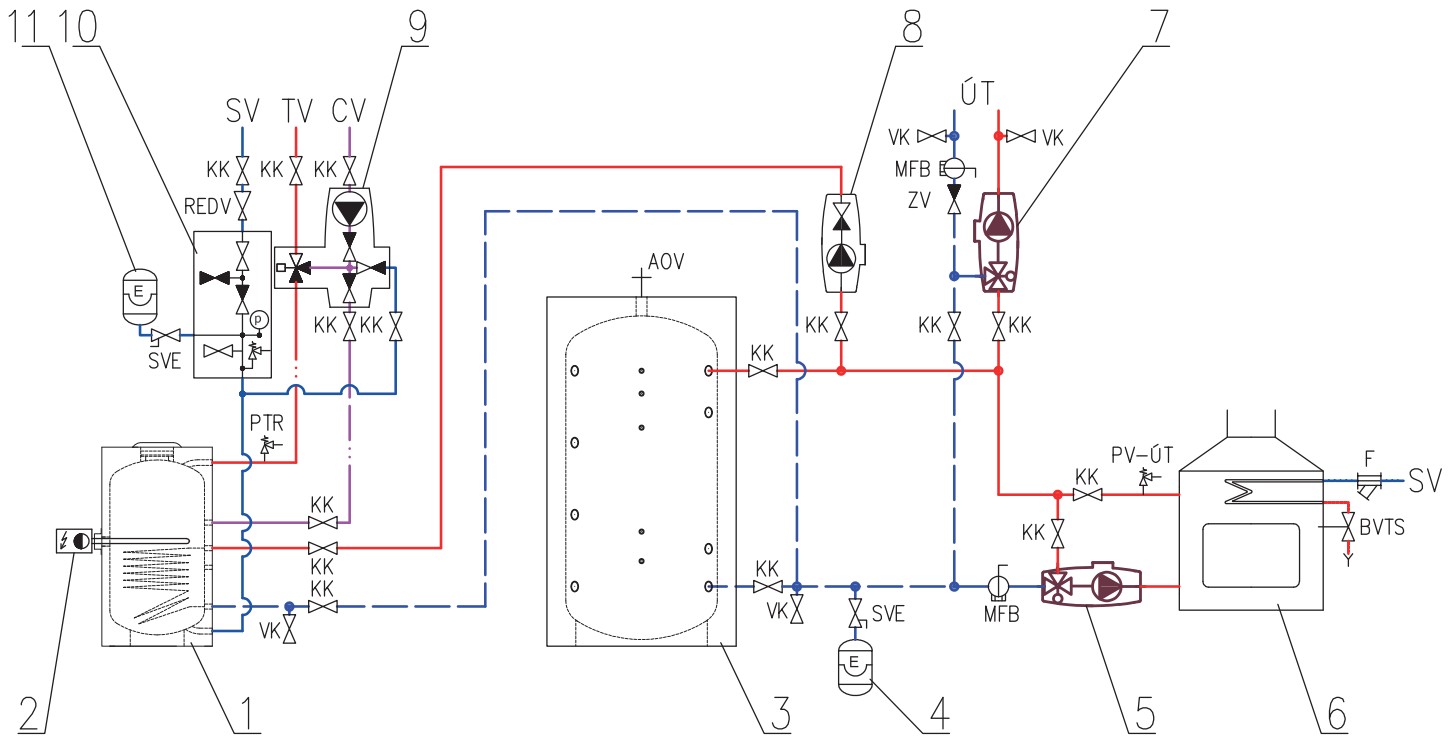

#### KEY

- 1 hot water storage tank
- 2 electric heating element w. thermostat
- 3 thermal store for heating system
- 4 expansion vessel for heating system
- 5 pump station for boiler – CSE MIX**
- 6 biomass boiler (fireplace insert/stove)
- 7 pump station for heating system – CSE MIX**
- 8 pump station for DHW heating – CSE OTS ZV
- 9 pump station for DHW recirculation – CSE TVMIX ZV
- 10 safety kit for HW storage tank
- 11 expansion vessel for DHW

- SV cold water
- TV hot water
- CV hot water recirculation
- ÚT central heating (heating system)

- KK ball valve
- ZV check valve
- AOV automatic air vent valve
- PTR pressure temperature relief valve
- REDV pressure reducing valve (optional)
- VK drain valve
- SVE expansion vessel service valve
- PV-ÚT central heating safety valve
- MFB Magnet Filterball
- F filter
- BVTs thermal safety relief valve for boiler

## 4. UPM3 FLEX AS 25-75 130 mm Pump

Wet-running circulation pump with G 6/4" M connection.

### Pump Wiring

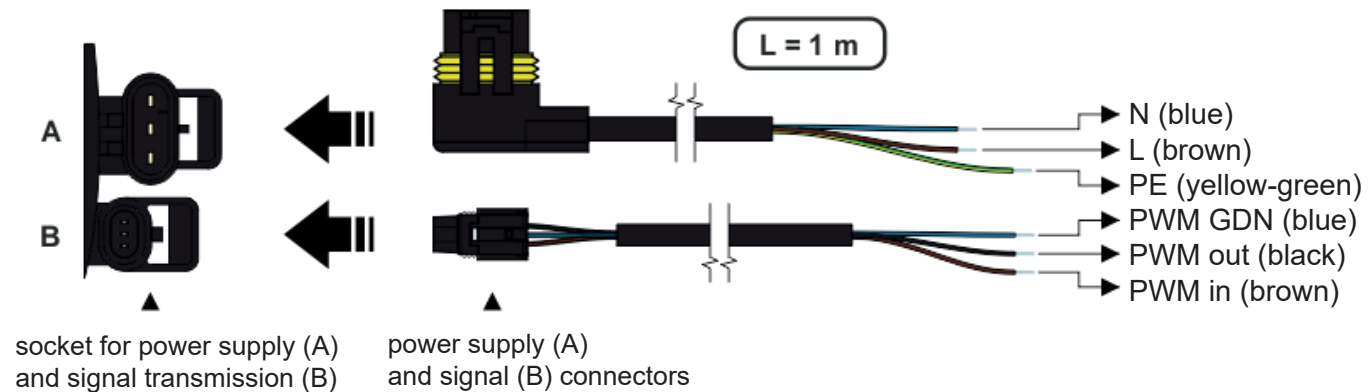

### Pump control

The circulation pump can be controlled by an external PWM signal (profile for use in heating systems) or without a PWM signal by selecting a pump performance curve.

A maximum curve of a pump working range can be defined.

- with PWM signal the pump speed changes with the signal value up to the maximum of the selected curve
- without PWM signal the pump runs at the max. speed according to the selected curve

### Performance curves

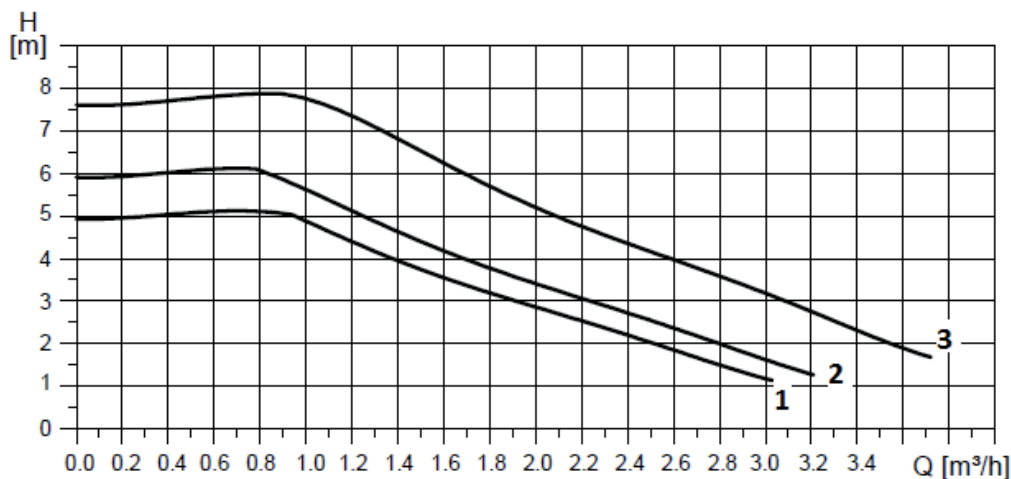

| Curve | Max. H<br>(upper graph) | Max. P <sub>1</sub><br>(lower graph) |
|-------|-------------------------|--------------------------------------|
| 1     | 5 m                     | 33 W                                 |
| 2     | 6 m                     | 39 W                                 |
| 3     | 7.5 m                   | 60 W                                 |

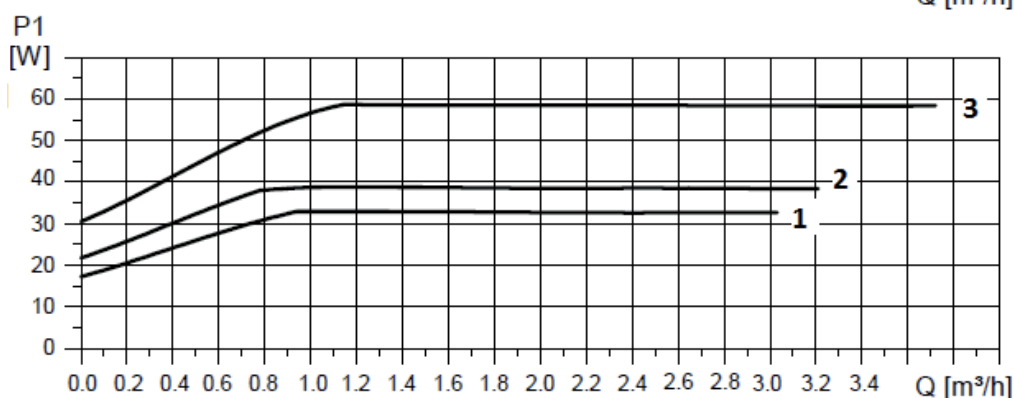

## Performance Display



The LED marking is further omitted for better clarity.

| DISPLAY | PERFORMANCE CURVE | STATUS             | Max. H (upper graph) |
|---------|-------------------|--------------------|----------------------|
|         | 1                 | LOW PERFORMANCE    | 5 m                  |
|         | 2                 | MEDIUM PERFORMANCE | 6 m                  |
|         | 3                 | HIGH PERFORMANCE   | 7.5 m                |

**WARNING:** LEDs may be turned by 90° or 180°, or mirrored, depending on the specific pump type.

| GREEN LED FLASHING FREQUENCY | PWM SIGNAL RECEPTION |
|------------------------------|----------------------|
| 1 flash per second           | NO                   |
| 8 flashes per second         | YES                  |

When switched on, the pump runs at factory settings or the last setting. The display shows the current pump performance.

## Setting Selection for UPM3

To select your desired setting, press the button repeatedly until you find the setting you need (see the table above). If you pass the desired setting, you have to go one more round until it appears again.

## Error Display

| DISPLAY | CONTROL MODE                 |
|---------|------------------------------|
|         | Seized pump                  |
|         | Too low power supply voltage |
|         | Electric fault               |

## 5. Permissible and Prohibited Pump Station Positions

The pump station may be installed either horizontally or vertically.



## 6. Pump Station Pressure Drop Graph

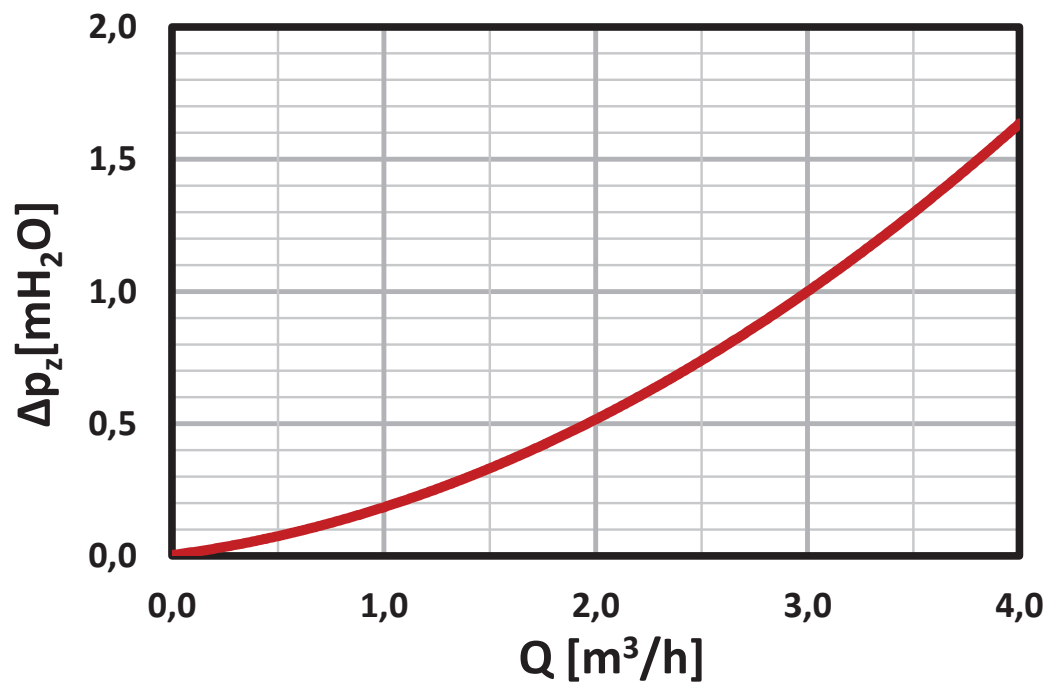



## 7. Installation options

The pump station comes with a mixing valve in the left-hand position (see Fig. 1). If this installation position is convenient, there is no need to make any adjustments. When needed, the mixing valve can be rotated to the right-hand position (see Fig. 2).

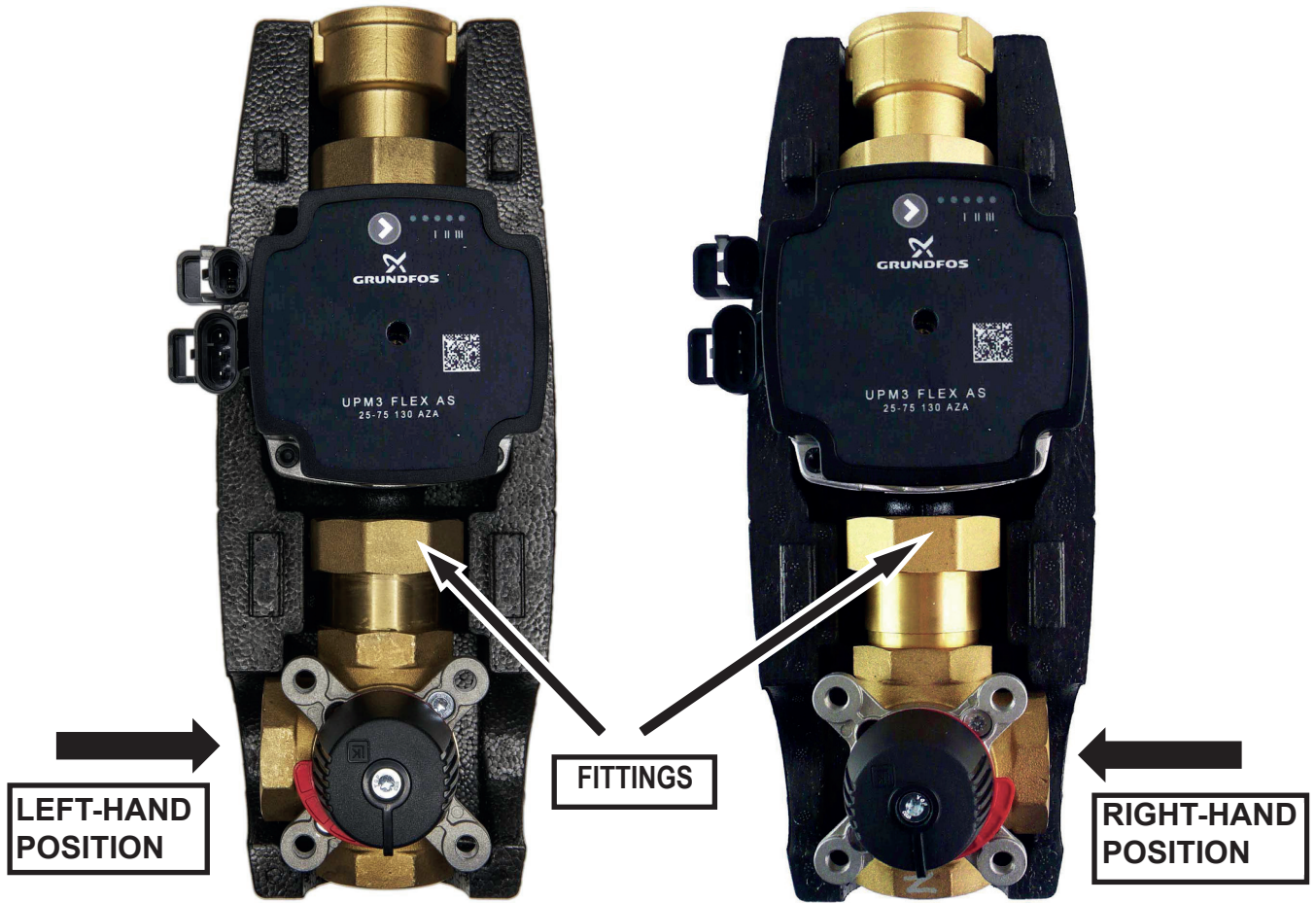
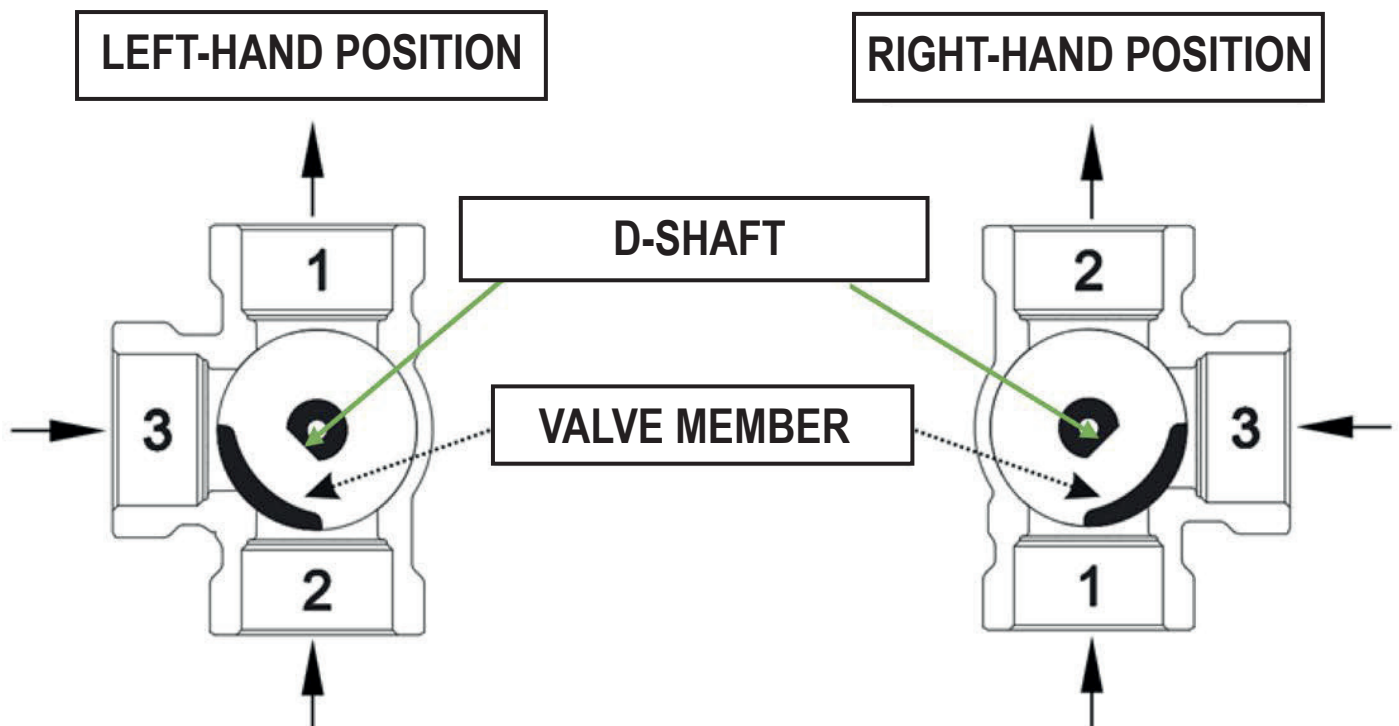

Fig. 1

Fig. 2

### Turning the valve to the right-hand position



**(Italics in bold** indicate the changes in procedure for re-positioning the valve back to the **left-hand position** from the right-hand position.)

|          |  |
|----------|--|
| <b>1</b> | Loosen the fittings, turn the valve by 180° into the right-hand ( <b>left-hand</b> ) position, tighten the fittings.   |
| <b>2</b> | Remove the rotating knob.  |
| <b>3</b> | Remove the red plastic wheel and fit it in the opposite position so that the letter L ( <b>R</b> ) points to the right ( <b>left</b> ) - in the direction of inlet 3.                            |
| <b>4</b> | Turn the D-shaft in such a manner that its flat edge is located between inlets 1 and 3 ( <b>2 and 3</b> ).<br><b>The flat edge of the shaft is located at the same side as the valve member!</b> |
| <b>5</b> | Refit the rotating knob. Its arrow (protrusion) shall point also between inlets 1 and 3 ( <b>2 and 3</b> ). Only in this position the knob will fit onto the shaft. Fix the knob by screw.       |