

Installation and Operation Instructions

HEAT ACCUMULATION TANKS PSW 200 N, PSWF 300 N, PSWF 500 N, PSWF 650 N, PSWF 800 N, PSWF 1000 N, PSWF 1500 N and PSWF 2000 N



CE

EN
v. 1.2

Regulus

CONTENTS

1 Description	3
1.1 Models	3
1.2 Tank protection	3
1.3 Thermal insulation	3
1.4 Connection points on the tank	3
1.5 Packing	3
2 General Information	3
3 Technical Data and Dimensions	4
4 Operation	5
5 Examples of ports allocation	5
6 Installation and Commissioning	7
7 Installing Insulation on the Tank	8
8 Maintenance	10
9 Disposal	10
10 Warranty	10

1 - Description

PSWF Accumulation Tanks are intended for accumulation and subsequent distribution of thermal energy from solid-fuel fired boilers, heat pumps, solar collectors, electric boilers etc. This accumulation tank shall be always connected to a sealed heating circuit. It is fitted with one upper flange ready to receive a suitably sized tube heat exchanger. A heat exchanger with 1" connections is installed in the bottom part. Mating flanges for heat exchangers with either G 1" or G 3/4" connections are available as an option. When no heat exchanger is installed, a blind flange shall be used (option). These heat exchangers are made of finned copper tubes that feature larger surface area and better heat transfer. The lower heat exchanger usually connects to a solar system and the upper one is used for DHW heating (continuous) which limits significantly the risk of Legionella bacteria formation. The tanks are also fitted with nine G 6/4" side sleeves to connect heat sources, four G 1/2" ones for sensor sheaths and one G 1/2" sleeve for a safety valve. EI. heating elements can be installed directly into the 6/4" sleeves.

In order to reach proper working of the tank, it is necessary to design optimum hydraulics of the whole system, i.e. position of circulation pumps for sources and heating circuits, valves, non-return valves etc. When more heat sources shall be combined, it is recommended to use an intelligent controller, e.g. Regulus IR, for both the source and load sides of a heating circuit, i.e. also for charging and discharging the accumulation tank.

1.1 - Models

Eight models of 182, 280, 472, 654, 807, 930, 1498 and 1997 l capacity.

1.2 - Tank protection

The inner surface has no finish, no anticorrosion protection, the outer surface is lacquered in gray.

1.3 - Thermal insulation

Tank insulation is available as a separate item, installed on the tank on the spot for easier handling. The insulation is made of 100 mm thick flexible polyurethane foam and fitted with a zippered PVC surface layer.

1.4 - Connection points on the tank

1 flange with 210 mm inner diam. (except for PSW 200 N)
8 side sleeves in a 90° sector, G 6/4" F thread
1 top sleeve, G 6/4" F thread
4 side sleeves for sensor sheaths, G 1/2" F thread
1 side sleeve for a 3 bar safety valve (included), G 1/2" F thread
2 side sleeves for a heat exchanger, G 1" F thread

1.5 - Packing

Tanks are delivered standing, each screwed to its pallet, packed in bubble wrap. Included in the package are gaskets, bolts for the flange and a 3 bar safety valve with G 1/2" F thread.

2 - General Information

This Owners Manual is an integral and important part of the product and must be handed over to the User. Read carefully the instructions in this Manual as they contain important information concerning safety, installation, operation and maintenance. Keep this Manual for later reference. The appliance shall be installed by a qualified person according to valid rules and Manufacturer's Instructions.

This appliance is designed to accumulate heating water and distribute it subsequently. It shall be connected to a heating system and heat sources. The equipment is suitable also for continuous water heating. In such a case, the customer needs to buy a suitably sized heat exchanger (available as accessory) and have it installed into the flange (not for PSW 200 N).

Using the accumulation tank for other purposes than above described (e.g. as a DHW tank) is forbidden and the manufacturer accepts no responsibility for damage caused by improper or wrong use.

3 - Technical Data and Dimensions

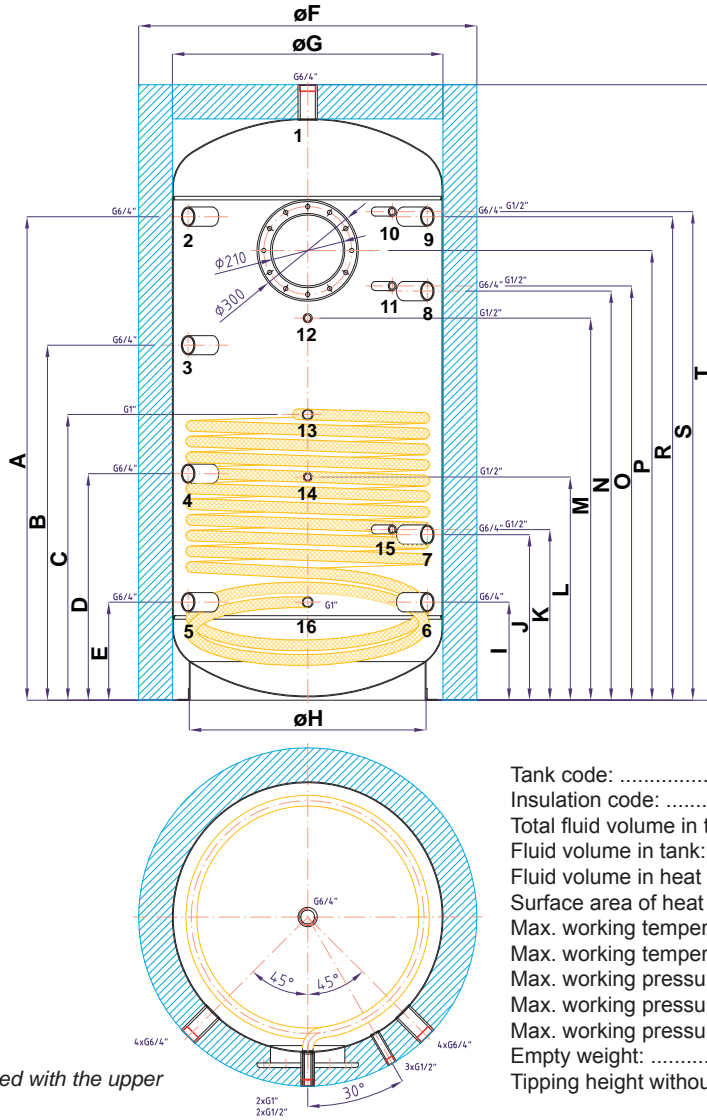

- Tank code: a
- Insulation code: b
- Total fluid volume in tank: c
- Fluid volume in tank: d
- Fluid volume in heat exchanger: e
- Surface area of heat exchanger: f
- Max. working temperature in tank: 95 °C
- Max. working temperature in heat exchanger: 110 °C
- Max. working pressure in tank PSW 200 N ÷ PSWF 1000 N: 4 bar
- Max. working pressure in tank PSWF 1500 N ÷ PSWF 2000 N: 3 bar
- Max. working pressure in heat exchanger: 10 bar
- Empty weight: g
- Tipping height without insulation: h

* PSW 200 N is not fitted with the upper flange.

Type - model		PSW 200 N*	PSWF 300 N	PSWF 500 N	PSWF 650 N	PSWF 800 N	PSWF 1000 N	PSWF 1500 N	PSWF 2000 N
Tank code	a	10096	10097	10098	10099	10100	10101	10142	10143
Insulation code	b	10127	10128	10129	10130	10131	10132	10151	10152
Total fluid volume in tank [l]	c	182	280	472	654	807	930	1498	1997
Fluid volume in tank [l]	d	176	271	461	641	792	912	1476	1971
Fluid volume in heat exchanger [l]	e	6,0	8,4	11,1	12,1	15,0	18,0	22,1	25,0
Heat exchanger surface area [sqm]	f	1,0	1,5	2,0	2,2	2,7	3,2	4,0	4,5
Empty weight [kg]	g	65	86	117	134	159	179	263	309
Tipping height without insulation [mm]	h	-	-	1911	1985	1859	2105	1934	2016
Dimensions [mm]	A	1068	1095	1590	1610	1430	1680	1450	1485
	B	768	770	1130	1150	1050	940	1070	1105
	C	548	645	660	715	845	939	913	930
	D	468	495	560	680	670	750	690	725
	E	168	195	200	220	290	290	310	345
	ø F	650	750	800	900	1000	1000	1300	1450
	ø G	450	550	600	700	800	800	1100	1250
	ø H	340	450	500	600	700	700	1000	1100
	I	168	195	200	220	290	290	310	345
	J	308	335	410	430	490	500	510	545
	K	308	350	425	445	505	515	525	560
	L	420	495	740	555	660	730	710	1040
	M	818	805	1245	1265	1130	1335	900	1185
	N	868	855	1360	1380	1210	1450	1230	1265
	O	968	870	1375	1395	1225	1465	1245	1280
	P	-	985	1490	1510	1330	1595	1350	1385
	R	1068	1095	1590	1610	1430	1680	1450	1485
	S	1068	1110	1605	1625	1445	1695	1465	1500
	T	1326	1380	1890	1930	1820	2070	1860	1930

4 - Operation

This accumulation tank is designed to accumulate heat and heat water for space heating in domestic or industrial applications, however always in sealed pressure circuits with forced circulation. In the accumulation tank, heating water is heated up from several heat sources like various types of hot-water boilers, renewable energy sources (heat pumps, solar collectors), or electric heating elements.

The accumulation tank shall be connected to a heat source through G 6/4" threaded fittings. A solar system connects to the outlets of the inbuilt heat exchanger through G 1" threaded fittings.

Individual connection points are assigned according to the circuits to be connected. There is a wide choice of combinations, just some examples are described in the following chapter.

5 - Examples of ports allocation

Conn. point	Example I. Solar collectors + el. heating elements	Example II. Solar collectors + gas boiler	Example III. Solar collectors + solid fuel boiler + el. heating elements
1	outlet to heating system	outlet to heating system	outlet to heating system
2	plug (inlet from fireplace)	outlet to gas boiler	inlet from boiler
3	el. heating element	plug (inlet from heat pump)	el. heating element
4	plug (outlet from heat pump)	plug	plug
5	plug (outlet to fireplace, heat pump)	plug (outlet to fireplace, heat pump)	outlet to boiler (fireplace)
6	drain valve	drain valve	drain valve
7	inlet from heating system	inlet from heating system.	inlet from heating system
8	el. heating element	plug	el. heating element
9	plug	plug (inlet from fireplace), from heating system	plug (inlet from fireplace)
10	thermostats for heating elements (adjustable+limit)	temperature sensor to heating controller	thermostats for heating elements (adjustable+limit)
11	temperature sensor to heating controller	thermometer	temperature sensor to heating controller
12	thermometer	plug	thermometer
13	inlet from solar system	inlet from solar system	inlet from solar system
14	temperature sensor to solar controller	temperature sensor to solar controller	temperature sensor to solar controller
15	safety valve, G 1/2", 3 bar	safety valve, G 1/2", 3 bar	safety valve, G 1/2", 3 bar
16	outlet from solar system	outlet from solar system	outlet from solar system
upper flange	heat exchanger for preheating DHW tank	heat exchanger for preheating DHW tank	heat exchanger for preheating DHW tank

Connections depend on the circuit to be connected, the a.m. examples are informative only.

* possible variants with a fireplace and a heat pump shown in brackets

Example I.

Solar collectors and el. heating elements.

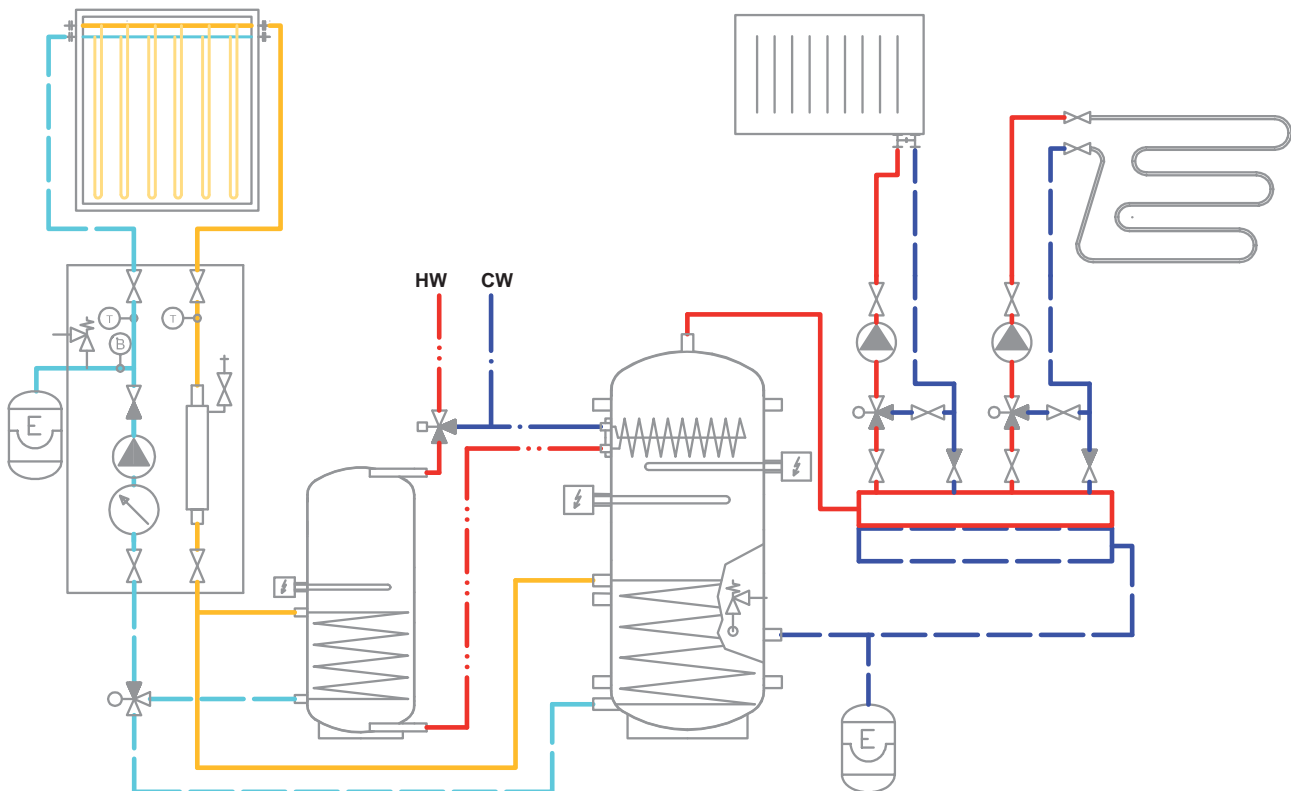

Example II.
Solar collectors and combi gas boiler.

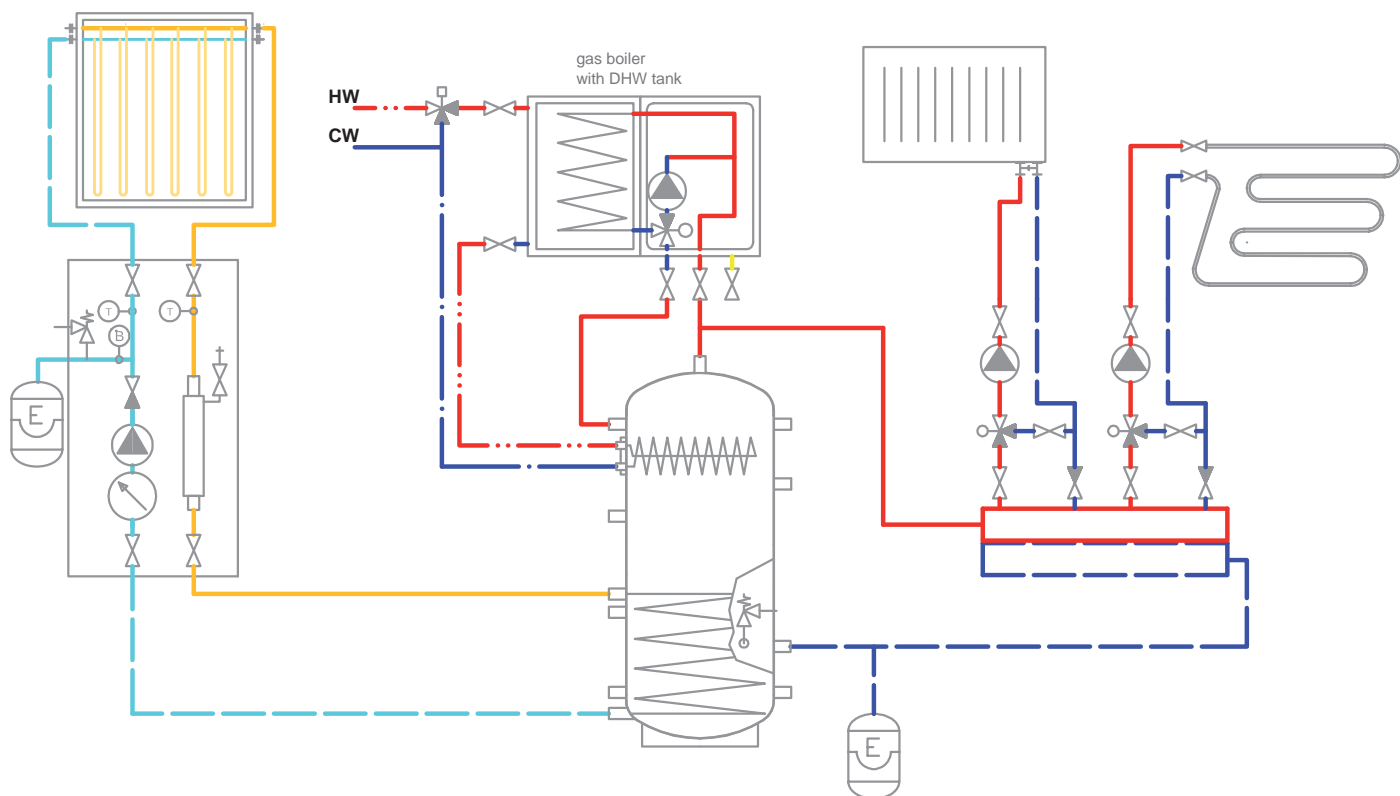

Example III.
Solar collectors, solid fuel boiler and el. heating elements.

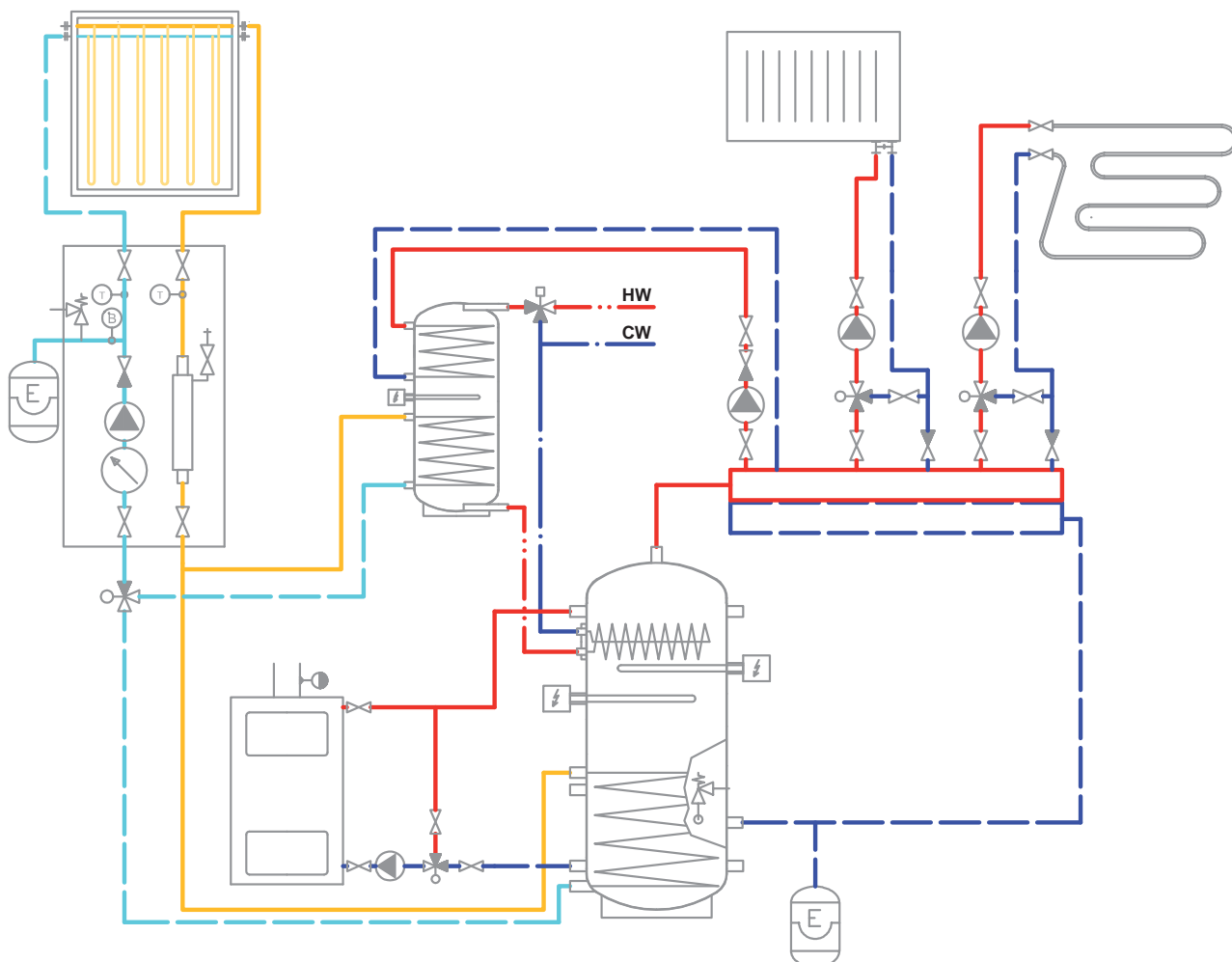

6 - Installation and Commissioning

Installation shall meet valid rules and may be done by qualified staff only.

Defects caused by improper installation, use or handling are not covered by warranty.

After the tank is installed and connected to an existing heating system, it is recommended to clean the entire heating system using a suitable cleaning agent, e.g. MR-501/R.

Anti-corrosion protective liquid should be also used, e.g. MR-501/F or F1.

6.1 - Connection to heat sources

Place the tank on the floor, as close to your heat source as possible. Mount the insulation, cf. Installing Insulation on the Tank. Connect the heating circuits to inlets and outlets respecting the thermal stratification in the tank. Install a drain valve at the lowest point of the tank. Install an air vent valve at the highest point of the system. Insulate all the connecting piping.

6.2 - Connection to a solar system

This tank is suitable for use with a solar system. In such a case the inlet of heated solar fluid from collectors connects to the G 1" upper sleeve of the heat exchanger and the return line from the solar system connects to its lower sleeve. Insulate meticulously all the piping between the tank and the solar system.

6.3 - El. heating element installation

The tank may be fitted with electric heating elements up to 12kW output. They can be power-supplied either directly (elements with built-in thermostat) or via a controller for the entire heating system.

All electric heating elements shall be protected by a safety thermostat.

Electric heating elements shall be installed by an authorized person only.

6.4 - Commissioning

The tank shall be filled up together with the heating system, respecting valid standards and rules. In order to minimize corrosion, special additives for heating systems should be used. The quality of heating water depends on the quality of filling water at commissioning, on the top-up water and on the frequency of topping up. This has a strong influence on the lifetime of heating systems. Poor quality of heating water may cause problems like corrosion or incrustation, esp. on heat transfer surfaces.

Fill the heating circuits with the appropriate fluids and air-bleed the entire system. Check all connections for leaks and verify the system pressure. Set the heating controller in compliance with the documentation and manufacturer's recommendations. Check regularly proper function of all control and adjustment elements.

7 - Installing Insulation on the Tank

Instructions

Product description

Thermal insulation of flexible polyurethane foam with a zippered PVC surface layer.

Warning

Insulation installation shall be done in two or three persons, depending on its size. The zippered, PVC coated flexible-foam insulation **must not be installed at temperatures below 20 °C**. If this cannot be avoided, the insulation shall be pre-warmed in another room to at least 20 °C. It is impossible to install insulation of lower temperature, there is a risk of damage, esp. to the zipper.

Do not use any tools for installation.

Keep away from open fire.

Installing Insulation

1. Fix the tank following installation instructions.
2. Wrap the insulation around the tank carefully. Check that the insulation adheres to its body perfectly. This can be reached by rubbing and patting the insulation by hand from its center evenly in both directions until the insulation adheres to the tank's surface completely and no bubbles are left.
3. Use the holes for sleeves as a rest during the insulation installation.
4. At least one person presses the insulation to the tank, pulling both ends together. The other person closes the zipper.
5. Put on the upper insulation and cover.
6. Push on the covering plastic rosettes depending on the size of sleeves, or put on the flange plug(s) with insulation.
7. Finish the tank installation in compliance with the respective instructions and valid standards and rules.

Warranty on insulation

The insulation is covered by a 24-month warranty. This period starts the next day after the insulation is sold.

□ Warranty shall become null and void if:

- the procedure described in the Installation Manual was not respected,
- the product was used for other purposes than intended.

□ Warranty does not cover:

- usual wear and tear,
- damage caused by fire, water, electricity or a natural disaster,
- defects caused by failure to use the product in compliance with its intended purpose, by improper use and insufficient maintenance,
- defects caused by mechanical damage to the product,
- defects caused by tampering or incompetent repair.



+ 20.0° C
+ 68.0° F

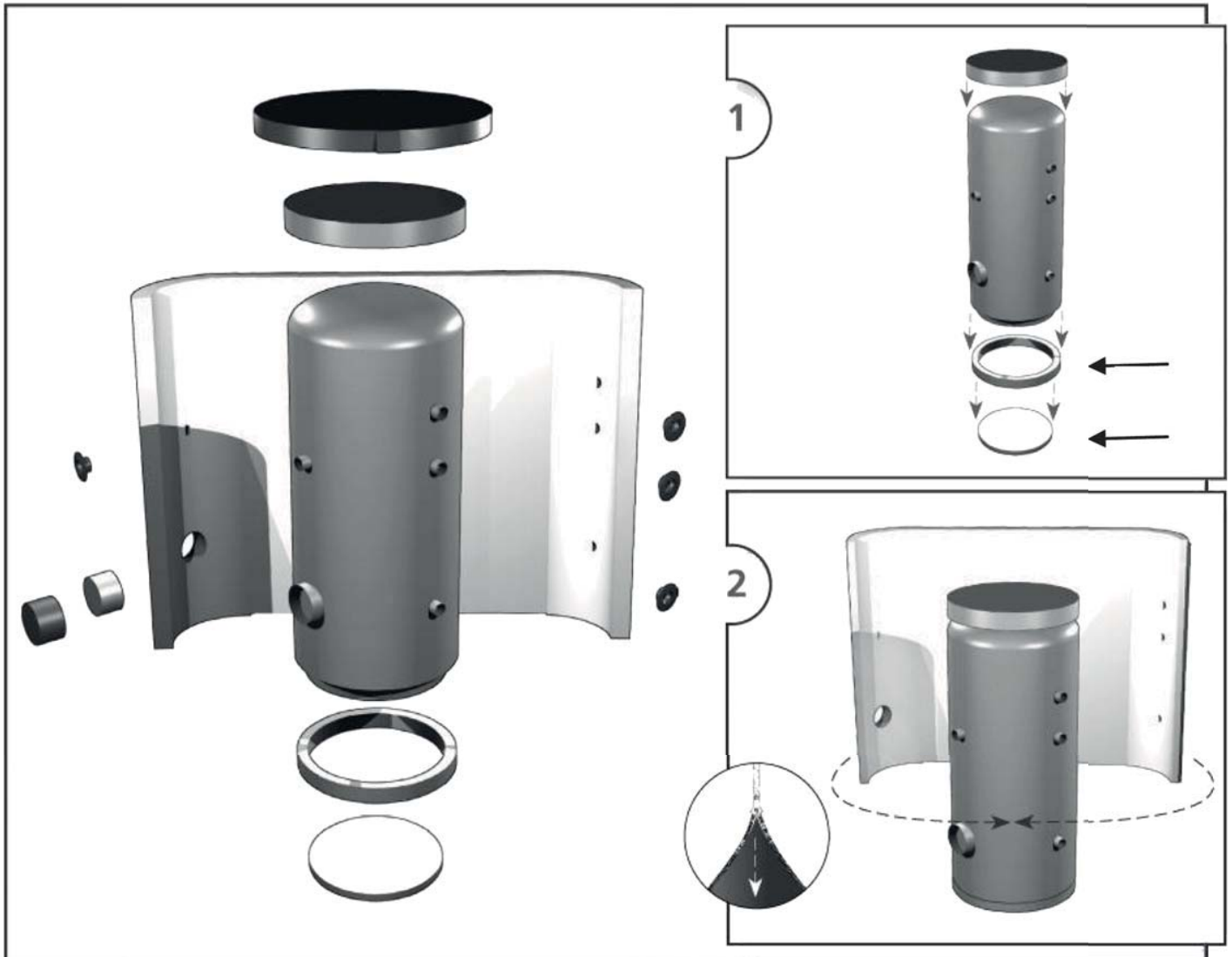

8 - Maintenance

If the tank is fitted with a heating element, disconnect it from the mains first. Clean the exterior of the tank with a soft cloth and a mild detergent. Never use abrasive cleaners or solvents. Check all connections for leaks.

9 - Disposal

Packing shall be disposed of in compliance with the valid rules. When the product reaches the end of its life, it shall not be disposed of as household waste. It shall be dropped off at a Local Waste Recycling Center. Insulation shall be recycled as plastic and the steel vessel as scrap iron.

10 - Warranty

This product is covered by warranty under the conditions listed in this Manual and in compliance with the Warranty Certificate. A Warranty Certificate is an integral part of this accumulation tank scope of supply.



REGULUS spol. s r.o.
Do Koutů 1897/3
143 00 Praha 4
CZECH REPUBLIC

<http://www.regulus.eu>
E-mail: sales@regulus.cz