

## Installation and Operation Instructions

THERMAL STORES PS2F 300 N, PS2F 500 N,  
PS2F 650 N, PS2F 800 N, PS2F 1000 N, PS2F  
1500 N and PS2F 2000 N



CE

EN  
v. 1.3

*Regulus*

# CONTENTS

<b>1 Description</b> .....	<b>3</b>
1.1 Models .....	3
1.2 Tank protection .....	3
1.3 Thermal insulation .....	3
1.4 Connection points on the tank .....	3
1.5 Packing .....	3
<b>2 General Information</b> .....	<b>3</b>
<b>3 Technical Data and Dimensions</b> .....	<b>4</b>
<b>4 Operation</b> .....	<b>5</b>
<b>5 Examples of ports allocation</b> .....	<b>5</b>
<b>6 Installation and Commissioning</b> .....	<b>7</b>
<b>7 Installing Insulation on the Tank</b> .....	<b>8</b>
<b>8 Maintenance</b> .....	<b>10</b>
<b>9 Disposal</b> .....	<b>10</b>
<b>10 Warranty</b> .....	<b>10</b>

## 1 - Description

PSWF Thermal Stores are intended for storing and subsequent distribution of thermal energy from solid-fuel fired boilers, heat pumps, solar collectors, electric boilers etc. This thermal store shall be always connected to a sealed heating circuit. It is fitted with two flanges ready to receive suitably sized tube heat exchangers. Mating flanges for heat exchangers with either G 1" or G ¾" connections are available as an option. When no heat exchanger is installed, a blind flange shall be used (option).

These heat exchangers are made of finned copper tubes that feature larger surface area and better heat transfer. The lower heat exchanger usually connects to a solar system and the upper one is used for DHW heating (continuous) which limits significantly the risk of Legionella bacteria formation. The tanks are also fitted with nine G 6/4" side sleeves to connect heat sources, four G ½" ones for sensor sheaths and one G ½" sleeve for a safety valve. EI heating elements can be installed directly into the 6/4" sleeves.

### 1.1 - Models

Seven models of 285, 479, 661, 809, 932, 1509 and 2010 l capacity.

### 1.2 - Tank protection

The inner surface has no finish, no anticorrosion protection, the outer surface is lacquered in gray.

### 1.3 - Thermal insulation

Tank insulation is available as a separate item, installed on the tank on the spot for easier handling. The insulation is made of 100 mm thick flexible polyurethane foam and fitted with a zippered PVC surface layer.

### 1.4 - Connection points on the tank

2 flanges with 210 mm inner diam.

8 side sleeves in a 90° sector, G 6/4" F thread

1 top sleeve, G 6/4" F thread

4 side sleeves for sensor sheaths, G ½" F thread

1 side sleeve for a 3 bar safety valve (included), G ½" F thread

### 1.5 - Packing

Tanks are delivered standing, each screwed to its pallet, packed in bubble wrap.

Included in the package are gaskets, bolts for the flange and a 3 bar safety valve with G ½" F thread.

## 2 - General Information

This Owners Manual is an integral and important part of the product and must be handed over to the User. Read carefully the instructions in this Manual as they contain important information concerning safety, installation, operation and maintenance. Keep this Manual for later reference. The appliance shall be installed by a qualified person according to valid rules and Manufacturer's Instructions.

This appliance is designed to accumulate heating water and distribute it subsequently. It shall be connected to a heating system and heat sources. The equipment is suitable also for continuous water heating. In such a case, the customer needs to buy a suitably sized heat exchanger (available as accessory) and have it installed into the upper flange.

**Using the thermal store for other purposes than above described (e.g. as a DHW tank) is forbidden and the manufacturer accepts no responsibility for damage caused by improper or wrong use.**

**The thermal store shall not be used as a DHW tank!**

### 3 - Technical Data and Dimensions

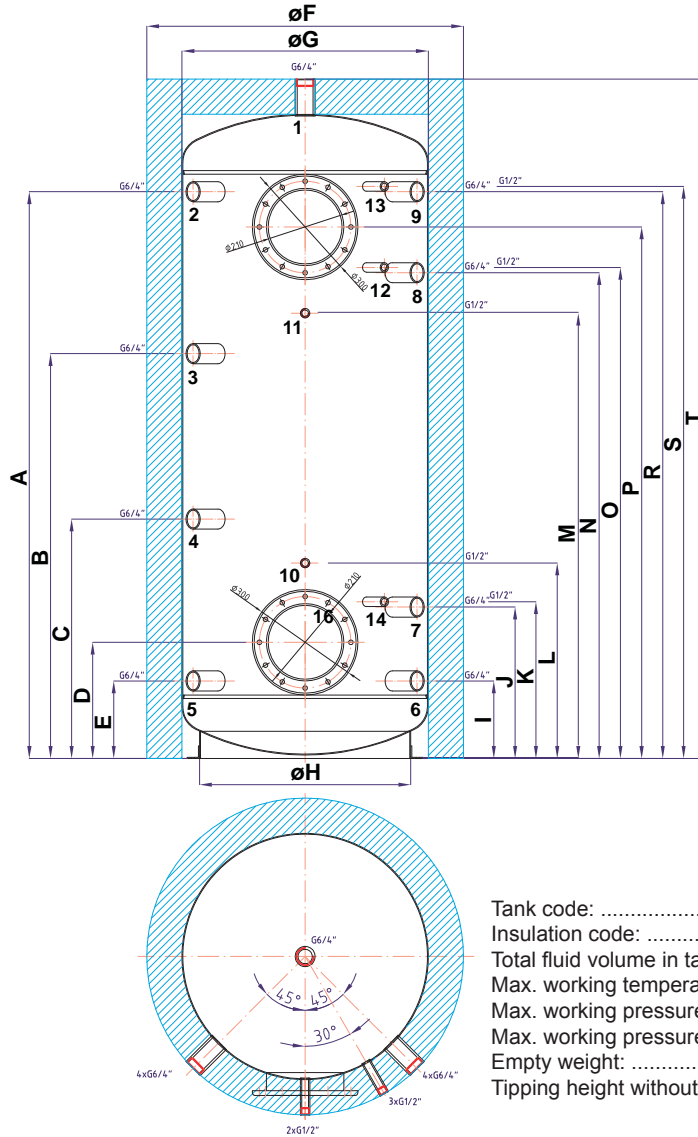

Tank code: ..... **a**  
 Insulation code: ..... **b**  
 Total fluid volume in tank: ..... **c**  
 Max. working temperature in tank: ..... **95 °C**  
 Max. working pressure in tank PS2F 300 N ÷ PS2F 1000 N: ..... **4 bar**  
 Max. working pressure in tank PS2F 1500 N ÷ PS2F 2000 N: ..... **3 bar**  
 Empty weight: ..... **d**  
 Tipping height without insulation: ..... **e**

Type - model		PS2F 300 N	PS2F 500 N	PS2F 650 N	PS2F 800 N	PS2F 1000 N	PS2F 1500 N	PS2F 2000 N
Tank code	<b>a</b>	10102	10103	10104	10105	10106	10144	10145
Insulation code	<b>b</b>	10133	10134	10135	10136	10137	10153	10154
Total fluid volume in tank [l]	<b>c</b>	285	479	661	809	932	1509	2010
Empty weight [kg]	<b>d</b>	57	77	90	104	114	180	214
Tipping height without insulation [mm]	<b>e</b>	-	1920	1970	1870	2110	1940	2020
Dimensions [mm]	<b>A</b>	1095	1590	1610	1430	1680	1450	1485
	<b>B</b>	770	1130	1150	1050	1220	1070	1105
	<b>C</b>	495	660	680	670	750	690	725
	<b>D</b>	305	310	330	400	400	420	455
	<b>E</b>	195	200	220	290	290	310	345
	<b>ø F</b>	750	800	900	1000	1000	1300	1450
	<b>ø G</b>	550	600	700	800	800	1100	1250
	<b>ø H</b>	450	500	600	700	700	1000	1100
	<b>I</b>	195	200	220	290	290	310	345
	<b>J</b>	335	410	430	490	500	510	545
	<b>K</b>	425	425	445	505	515	525	560
	<b>L</b>	495	536	550	580	625	600	635
	<b>M</b>	805	1245	1265	1130	1335	1150	1185
	<b>N</b>	855	1360	1380	1210	1450	1230	1265
	<b>O</b>	870	1375	1395	1225	1465	1245	1280
	<b>P</b>	985	1490	1510	1330	1580	1350	1385
	<b>R</b>	1095	1590	1610	1430	1680	1450	1485
	<b>S</b>	1110	1605	1625	1445	1695	1465	1500
	<b>T</b>	1380	1890	1930	1820	2070	1860	1930

## 4 - Operation

This thermal store is designed to accumulate heat and heat water for space heating in domestic or industrial applications, however always in sealed pressure circuits with forced circulation. In the thermal store, heating water is heated up from several heat sources like various types of hot-water boilers, renewable energy sources (heat pumps, solar collectors), or electric heating elements.

The thermal store shall be connected to a heat source through G 6/4" threaded fittings. Should it be connected to a solar system, too, this shall be done through a suitably sized heat exchanger installed into the lower flange.

## 5 - Examples of ports allocation

Conn. point	Example I. Solar collectors + el. heating elements	Example II. Solar collectors + gas boiler	Example III. Solar collectors + solid fuel boiler + el. heating elements
1	outlet to heating system	outlet to heating system	outlet to heating system
2	plug	inlet to boiler (gas-fired)	inlet from boiler (solid-fuel-fired)
3	el. heating element	plug	el. heating element
4	plug	plug	plug
5	plug	plug	outlet to boiler (solid-fuel-fired)
6	drain valve	drain valve	drain valve
7	inlet from heating system	inlet from heating system	inlet from heating system
8	el. heating element	plug	el. heating element
9	plug	inlet from heating system	plug
10	temperature sensor for solar system	temperature sensor for solar system	temperature sensor for solar system
11	thermometer	thermometer	thermometer
12	thermostats for heating elements (adjustable+limit)	temperature sensor to heating controller	thermostats for heating elements (adjustable+limit)
13	sensor for controller with OTC	sensor for controller with OTC	sensor for controller with OTC
14	safety valve, G 1/2", 3 bar	safety valve, G 1/2", 3 bar	safety valve, G 1/2", 3 bar
upper flange	heat exchanger for preheating DHW tank	heat exchanger for preheating DHW tank	heat exchanger for preheating DHW tank
lower flange	solar heat exchanger	solar heat exchanger	solar heat exchanger

Connections depend on the circuit to be connected, the a.m. examples are informative only.

### Example I.

Solar collectors and el. heating elements.

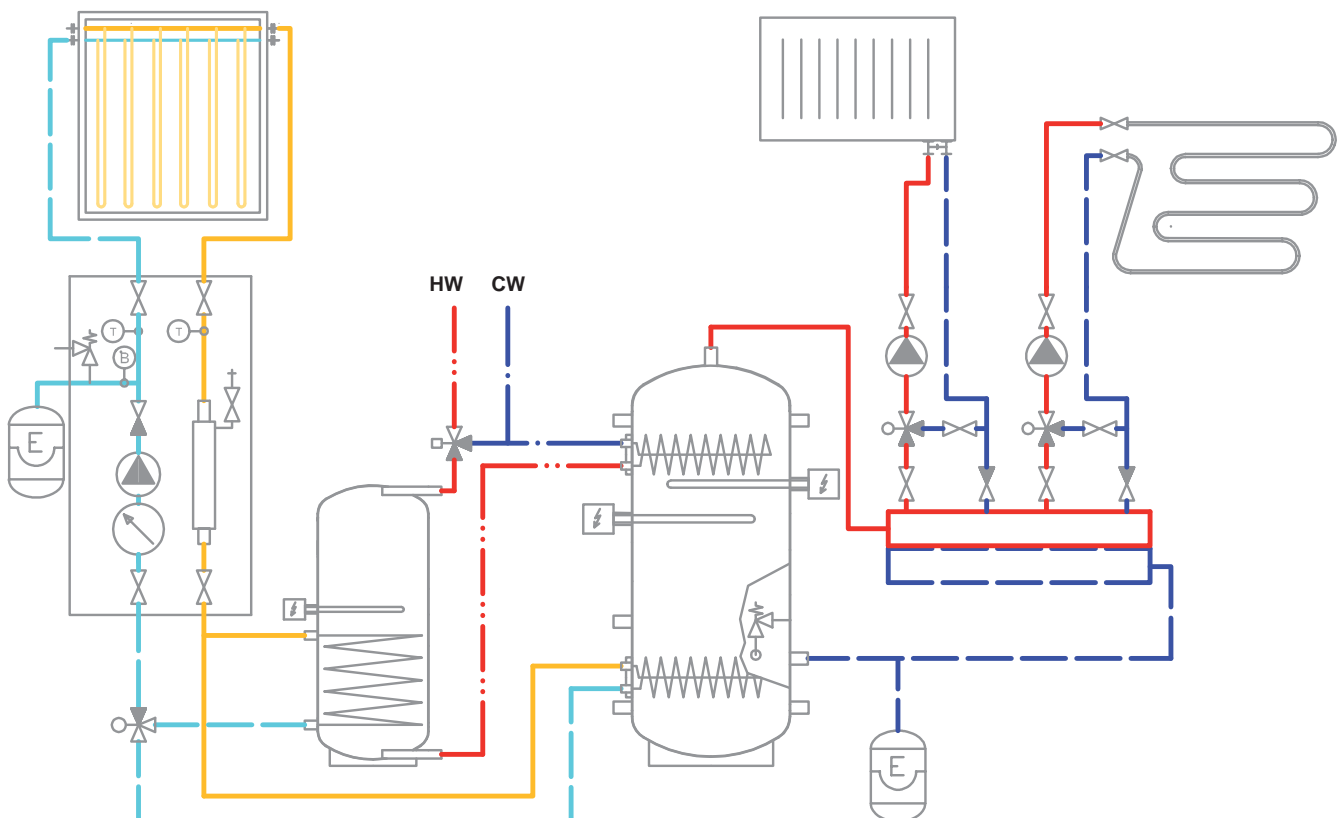

**Example II.**

Solar collectors and combi gas boiler.

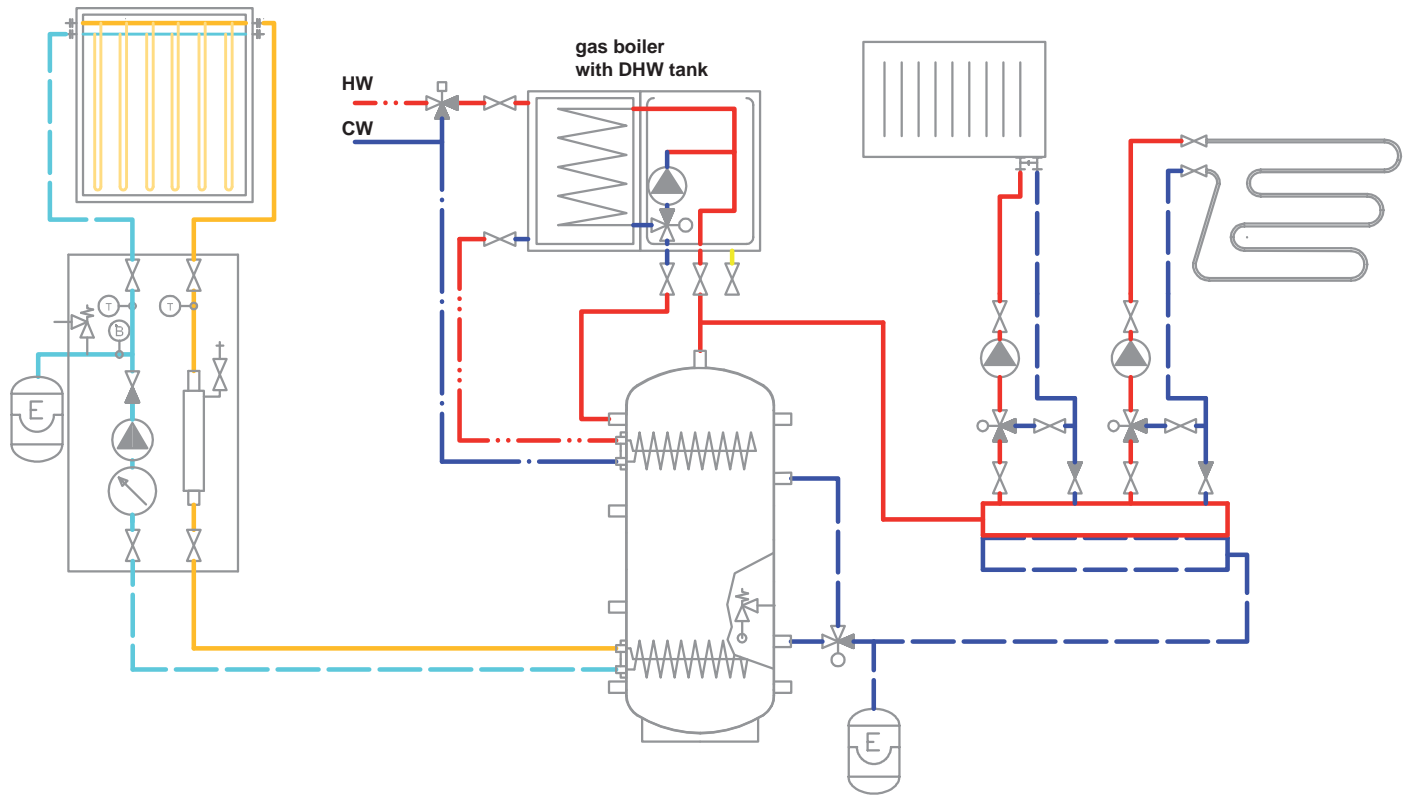

**Example III.**

Solar collectors, solid fuel boiler and el. heating elements.

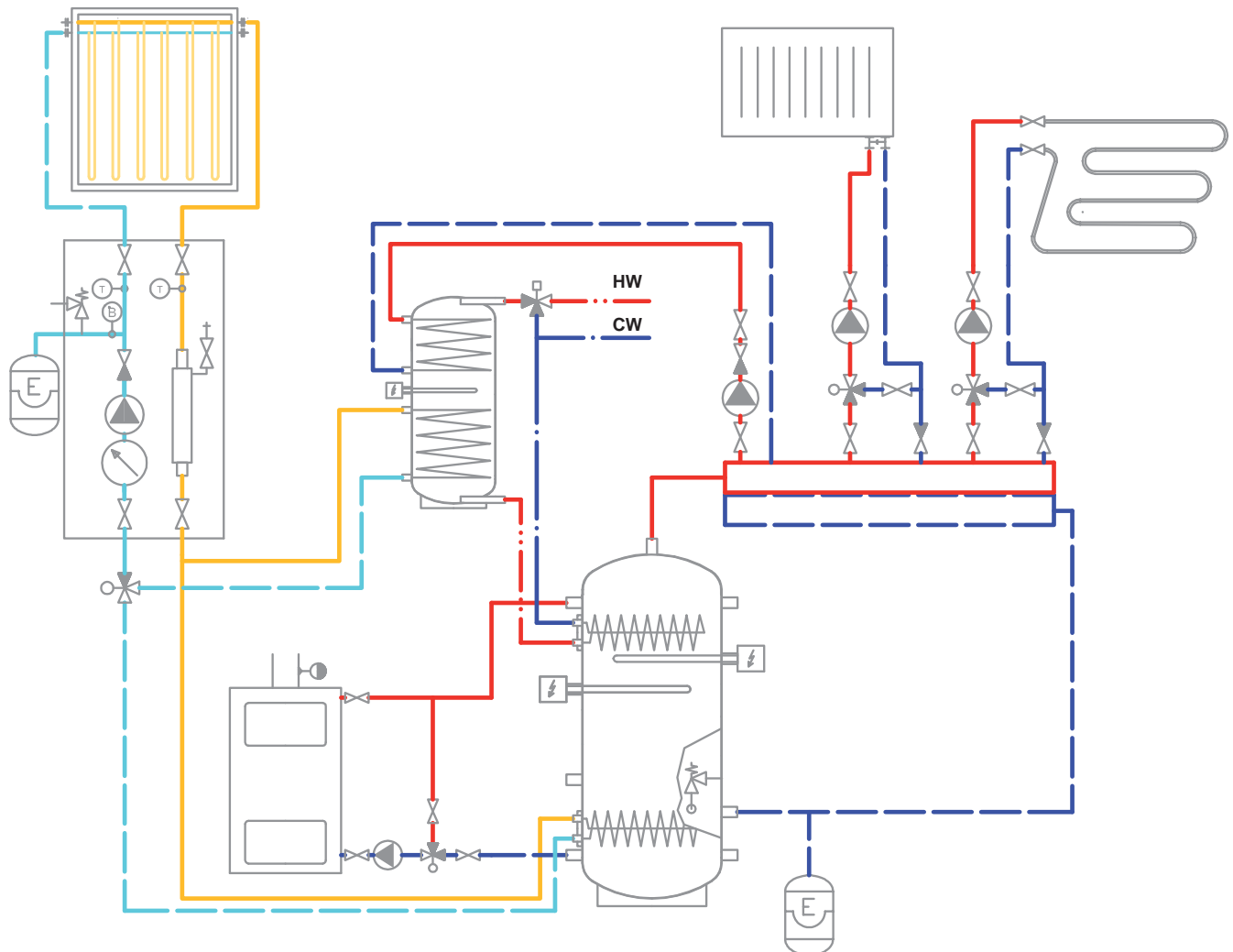

## 6 - Installation and Commissioning

Installation shall meet valid rules and may be done by qualified staff only.

**Defects caused by improper installation, use or handling are not covered by warranty.**

After the tank is installed and connected to an existing heating system, it is recommended to clean the entire heating system using a suitable cleaning agent, e.g. MR-501/R.

Anti-corrosion protective liquid should be also used, e.g. MR-501/F or F1.

### 6.1 - Connection to heat sources

Place the tank on the floor, as close to your heat source as possible. Mount the insulation, cf. Installing Insulation on the Tank. Connect the heating circuits to inlets and outlets respecting the thermal stratification in the tank. Install a drain valve at the lowest point of the tank. Install an air vent valve at the highest point of the system. Insulate all the connecting piping.

### 6.2 - Connection to a solar system

This tank is suitable for use with a solar system. In such a case a suitably sized heat exchanger shall be installed into the lower flange. Insulate meticulously all the piping between the tank and the solar system.

### 6.3 - El. heating element installation

The tank may be fitted with electric heating elements up to 12kW output. They can be power-supplied either directly (elements with built-in thermostat) or via a controller for the entire heating system.

**All electric heating elements shall be protected by a safety thermostat.**

Electric heating elements shall be installed by an authorized person only.

### 6.4 - Commissioning

The tank shall be filled up together with the heating system, respecting valid standards and rules. In order to minimize corrosion, special additives for heating systems should be used. The quality of heating water depends on the quality of filling water at commissioning, on the top-up water and on the frequency of topping up. This has a strong influence on the lifetime of heating systems. Poor quality of heating water may cause problems like corrosion or incrustation, esp. on heat transfer surfaces.

Fill the heating circuits with the appropriate fluids and air-bleed the entire system. Check all connections for leaks and verify the system pressure. Set the heating controller in compliance with the documentation and manufacturer's recommendations. Check regularly proper function of all control and adjustment elements.

## 7 - Installing Insulation on the Tank

### Instructions

#### Product description

Thermal insulation of flexible polyurethane foam with a zippered PVC surface layer.

#### Warning

Insulation installation shall be done in two or three persons, depending on its size. The zippered, PVC coated flexible-foam insulation **must not be installed at temperatures below 20 °C**. If this cannot be avoided, the insulation shall be pre-warmed in another room to at least 20 °C. It is impossible to install insulation of lower temperature, there is a risk of damage, esp. to the zipper.

Do not use any tools for installation.

Keep away from open fire.

#### Installing Insulation

1. Fix the tank following installation instructions.
2. Wrap the insulation around the tank carefully. Check that the insulation adheres to its body perfectly. This can be reached by rubbing and patting the insulation by hand from its center evenly in both directions until the insulation adheres to the tank's surface completely and no bubbles are left.
3. Use the holes for sleeves as a rest during the insulation installation.
4. At least one person presses the insulation to the tank, pulling both ends together. The other person closes the zipper.
5. Put on the upper insulation and cover.
6. Push on the covering plastic rosettes depending on the size of sleeves, or put on the flange plug(s) with insulation.
7. Finish the tank installation in compliance with the respective instructions and valid standards and rules.

#### Warranty on insulation

The insulation is covered by a 24-month warranty. This period starts the next day after the insulation is sold.

#### □ Warranty shall become null and void if:

- the procedure described in the Installation Manual was not respected,
- the product was used for other purposes than intended.

#### □ Warranty does not cover:

- usual wear and tear,
- damage caused by fire, water, electricity or a natural disaster,
- defects caused by failure to use the product in compliance with its intended purpose, by improper use and insufficient maintenance,
- defects caused by mechanical damage to the product,
- defects caused by tampering or incompetent repair.



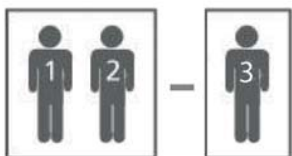

+ 20.0° C  
+ 68.0° F

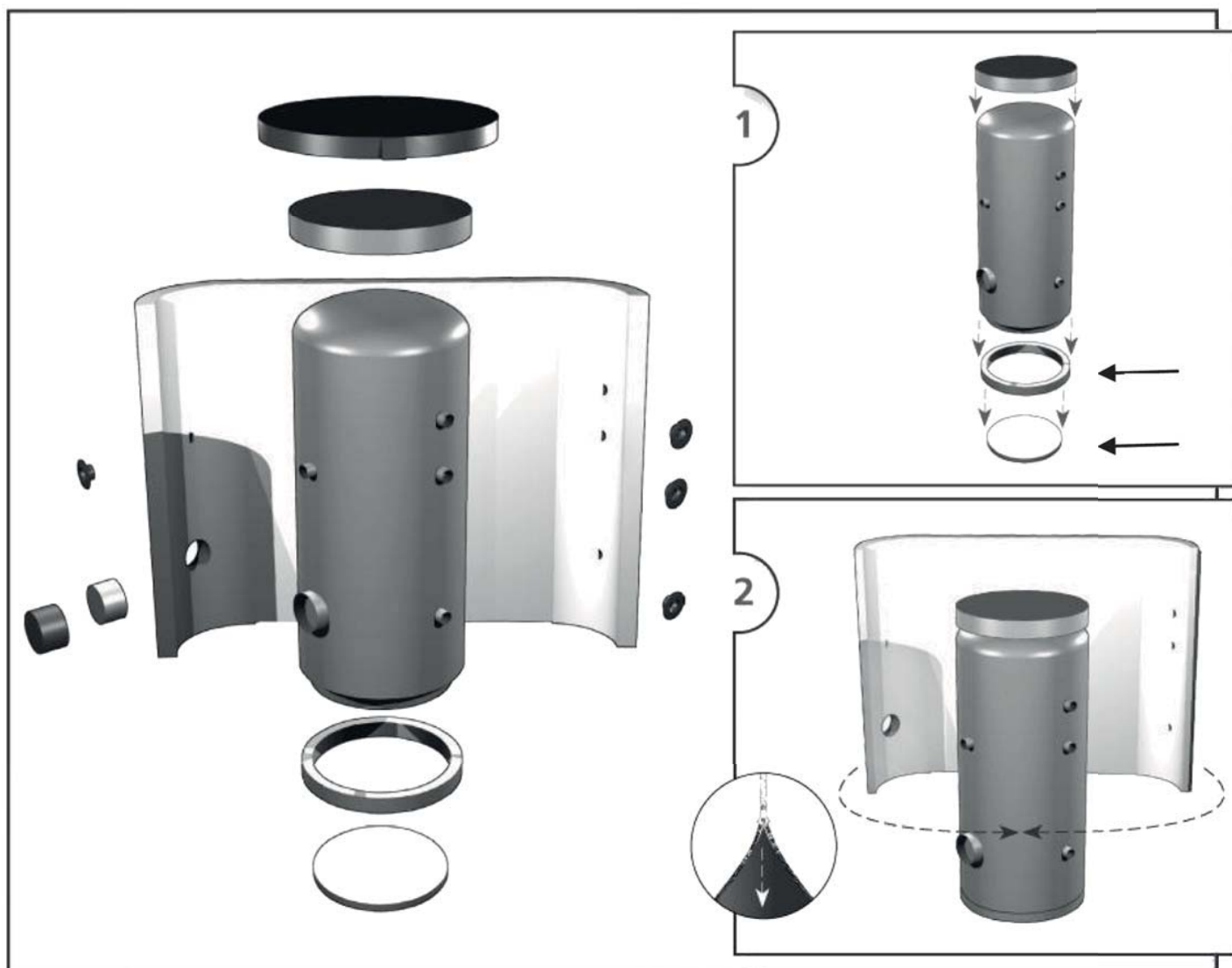

## 8 - Maintenance

If the tank is fitted with a heating element, disconnect it from the mains first. Clean the exterior of the tank with a soft cloth and a mild detergent. Never use abrasive cleaners or solvents. Check all connections for leaks.

## 9 - Disposal

Packing shall be disposed of in compliance with the valid rules. When the product reaches the end of its life, it shall not be disposed of as household waste. It shall be dropped off at a Local Waste Recycling Center. Insulation shall be recycled as plastic and the steel vessel as scrap iron.

## 10 - Warranty

This product is covered by warranty under the conditions listed in this Manual and in compliance with the Warranty Certificate. A Warranty Certificate is an integral part of this thermal store scope of supply.





**REGULUS spol. s r.o.**  
Do Koutů 1897/3  
143 00 Praha 4  
CZECH REPUBLIC

<http://www.regulus.eu>  
E-mail: [sales@regulus.cz](mailto:sales@regulus.cz)