

Heating Element with Thermostatic Head, single phase, fixed connection

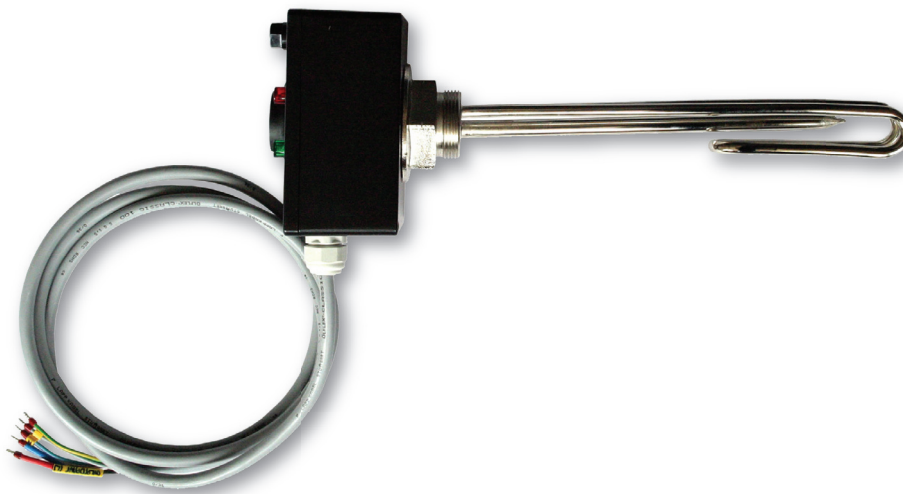

1 In General	2
1.1 Use	2
1.2 Installation	2
1.3 Maintenance	2
1.4 Disposal	2
2 Heating Element with Thermostatic Head, single-phase fixed wiring	3
2.1 Technical Description	3
2.2 Dimensions	3
2.3 Connection to the mains	3
2.4 Wiring diagram	4
2.4.1 Wiring diagram for the heating element	4
2.5 Commissioning, operation and possible faults	4
2.5.1 DHW heating in a storage water heater	4
2.5.2 Heating water for space heating in an accumulation tank	5
2.5.3 Heating element state during operation	5
2.5.4 Possible faults	5
3 Wiring examples for heating elements - controller- or thermostat-controlled	6

1 - In General

1.1 - Use

This electric heating element is designed to heat sanitary water in a storage water heater or heating water in an accumulation tank.

1.2 - Installation

Screw the heating element into the respective threaded sleeve (G 6/4" F) with the cable gland heading downwards. Sealing cord, hemp, Teflon tape or a semi-permanent thread sealant should be used to avoid leaks.

1.3 - Maintenance

Clean the exterior of the heating element with a soft cloth and a suitable detergent. Never use abrasive cleaners or solvents.

If the element is used in extra hard water, it is recommended to remove sediments at least once a year. Unplug the element before cleaning. Then drain water from the tank and dismount the heating element. Scratch the hard deposits on the heating rod with a plastic or wooden spatula and flush with water. Be careful not to damage the protective nickel layer on the heating rod. Then reinstall the body according to this instruction manual, fill the tank with water, air-bleed and pressurize it. Check the threaded connection for leaks. Finally, re-connect the heating element to the mains.

1.4 - Disposal

IMPORTANT INFORMATION ON PROPER DISPOSAL OF E-WASTE AS REQUIRED BY THE EC DIRECTIVE 2002/96/EC (WEEE)

Do not dispose of this product as unsorted municipal waste. Please dispose of this product by returning it to the point of sale or to your local municipal collection point for recycling.

Respecting these rules will help to preserve, protect and improve the quality of the environment, protect human health and utilize natural resources prudently and rationally.

The crossed out wheeled bin with marking bar, printed either in the Manual or on the product itself, identifies that the product must be disposed of at a recycling collection site.



WEEE Registration Number: 02771/07-ECZ

2 - Heating Element with Thermostatic Head, single-phase fixed wiring

2.1 - Technical Description

The electric heating element consists of a nickel-plated or stainless-steel heating rod with G 6/4" outer thread, a capillary thermostat adjustable between $0\pm 5\text{ }^{\circ}\text{C}$ and $90\pm 3\text{ }^{\circ}\text{C}$ (the lower limit is factory set to $15\text{ }^{\circ}\text{C}$ as a frost protection) with $7\pm 1\text{ }^{\circ}\text{C}$ switching difference, a manual reset safety capillary thermostat set to $99\text{ }^{\circ}\text{C}$ and $+0\text{ }^{\circ}\text{C}$, $-6\text{ }^{\circ}\text{C}$ tolerance, $5\times 1,5\text{ mm}^2$ power supply cable and LEDs showing the state of the heating element. The power supply cable is 2 m long.

2.2 - Dimensions

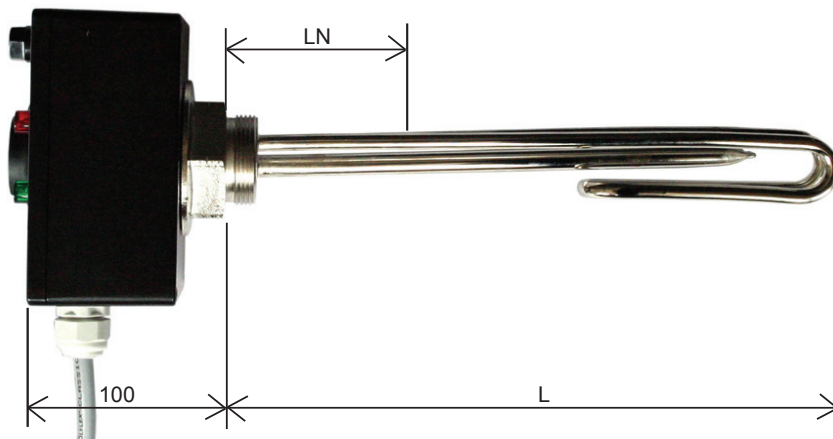

	output [kW]	el. wiring	type no.	code	material	LN-non-heating end [mm]	L-heating rod length [mm]	min. storage w. heater size	min. tank size	
230 V	2	1/N/PE AC 230V	01360/0010	10267	nickel-plated copper	100	315	RGC 120H	PS 200	HSK 500
	3	1/N/PE AC 230V	01360/0020	8933	nickel-plated copper	100	350			
	2	1/N/PE AC 230V	01360/1010	10116	stainless steel	100	470	NBC 200	-	-
	3	1/N/PE AC 230V	01360/1020	10117	stainless steel	100	350			

2.3 - Connection to the mains

The electric heating element shall be wired to a terminal box or electrical enclosure, 1/N/PE AC 230V, fixed wiring. The installation shall meet valid rules and standards and shall be done by an authorized person only. The wire marked N-MRC is intended to control the heating element with MRC. Should this connection remained unused, both the center blue wires (N and N-MRC) shall be joined together in the terminal box or electrical enclosure.

The wire marked CONTROL (L) is intended to control the heating element with a heating system controller. This wire shall be joined with the controller-switched line. In such a case, the temperature set with the thermostat knob shall be higher than that set by the controller. Should this connection remained unused, this wire shall be joined together with the L line in the terminal box or electrical enclosure.

2.4 - Wiring diagram

2.4.1 - Wiring diagram for the heating element

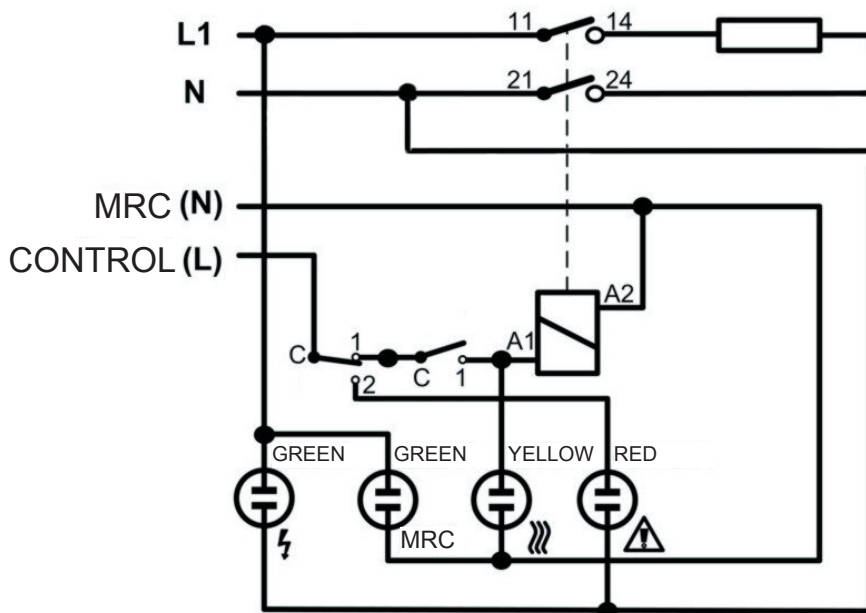

2.5 - Commissioning, operation and possible faults

Prior to commissioning, please make sure the water in direct contact with the heating element does not exceed the values given in the chart below. The manufacturer bears no responsibility for defects (e.g. limescale deposits on the heating element) caused by unsuitable operation conditions.

Table of limit values for total dissolved solids in hot water

Description	pH	Total dissolved solids (TDS)	Ca	Chlorides	Mg	Na	Fe
Max. value	6.5-9.5	600 mg/l	40 mg/l	100 mg/l	20 mg/l	200 mg/l	0.2 mg/l

2.5.1 - DHW heating in a storage water heater

In order to heat water in the storage water heater, open the cold water inlet, fill the tank with water and airbleed it by opening the hot-water tap. Set the thermostat knob to the desired temperature. Green and yellow LEDs will be lit on the heating element. As soon as the desired water temperature is reached, the yellow lamp will go out. The lit green LEDs show that the heating element is energized and MRC is on (low tariff).

If the green LED marked N-MRC is out, the MRC is off (high tariff). In case the cable marked N-MRC is joined with the middle N cable in a terminal box, both the green LEDs will be lit and go out simultaneously, showing that the heating element is energized.

It is recommended to set the thermostat knob to 60 °C. This temperature guarantees the best operation of the heating element and at the same time, it offers:



- protection against Legionella
- cost reduction
- slower deposit formation

2.5.2 - Heating water for space heating in an accumulation tank

Fill the heating system with heat-carrying fluid, air-bleed it and pressurize to the working pressure. Set the thermostat knob to the desired temperature. Green and yellow LEDs will be lit on the heating element. As soon as the desired temperature of liquid is reached, the yellow lamp will go out. The lit green LEDs show that the heating element is energized and MRC is on (low tariff). If the green LED marked N-MRC is out, the MRC is off (high tariff). In case the cable marked N-MRC is joined with the middle N cable in a terminal box, both the green LEDs will be lit and go out simultaneously, showing that the heating element is energized.

2.5.3 - Heating element state during operation

Heating element state under operation is shown as follows

Colour	Marking	Description
Green		The heating element is OK, energized and ready for operation.
Yellow	 ON	The heating element is heating
Red		The safety thermostat is OFF
Green	N-MRC	Low-tariff MRC is active

When the safety temperature is reached, the safety thermostat will cut off the heating element from power supply. This is signaled by a red LED. The green LED on (flash sign) means the heating element is energized. The safety thermostat requires manual reset. When the tank cools down, unscrew the lid of the heating element and press the button. The red light will go out and the heating element is ready again.

NOTE: If power supply (L) is turned off and at the same time MRC is turned off, then the heating element can be energized from the controller line CONTROL (L). This state is signaled by both green LEDs on.

2.5.4 - Possible faults

If the heating rod is controlled by a heating controller and the yellow LED won't get lit when the green ones are lit and the controller switches on, then probably the desired temperature set with the knob of the adjustable thermostat is lower than that set on the controller. Set the thermostat knob to a higher desired temperature. If this does not help, call your service provider.

If the tank gets overheated without using any other heat source (the adjustable thermostat probably does not turn off the heating element when the set temperature is reached - the yellow LED is on until the red one gets lit), call your service provider.

If the heating element shows signs of another defect (no green LED is lit or N-MRC only, although energized, or both red and yellow LEDs are lit simultaneously etc.), disconnect it from the mains immediately and call your service provider.

3 - Wiring examples for heating elements

controller- or thermostat-controlled

System controlled with an external controller, without MRC

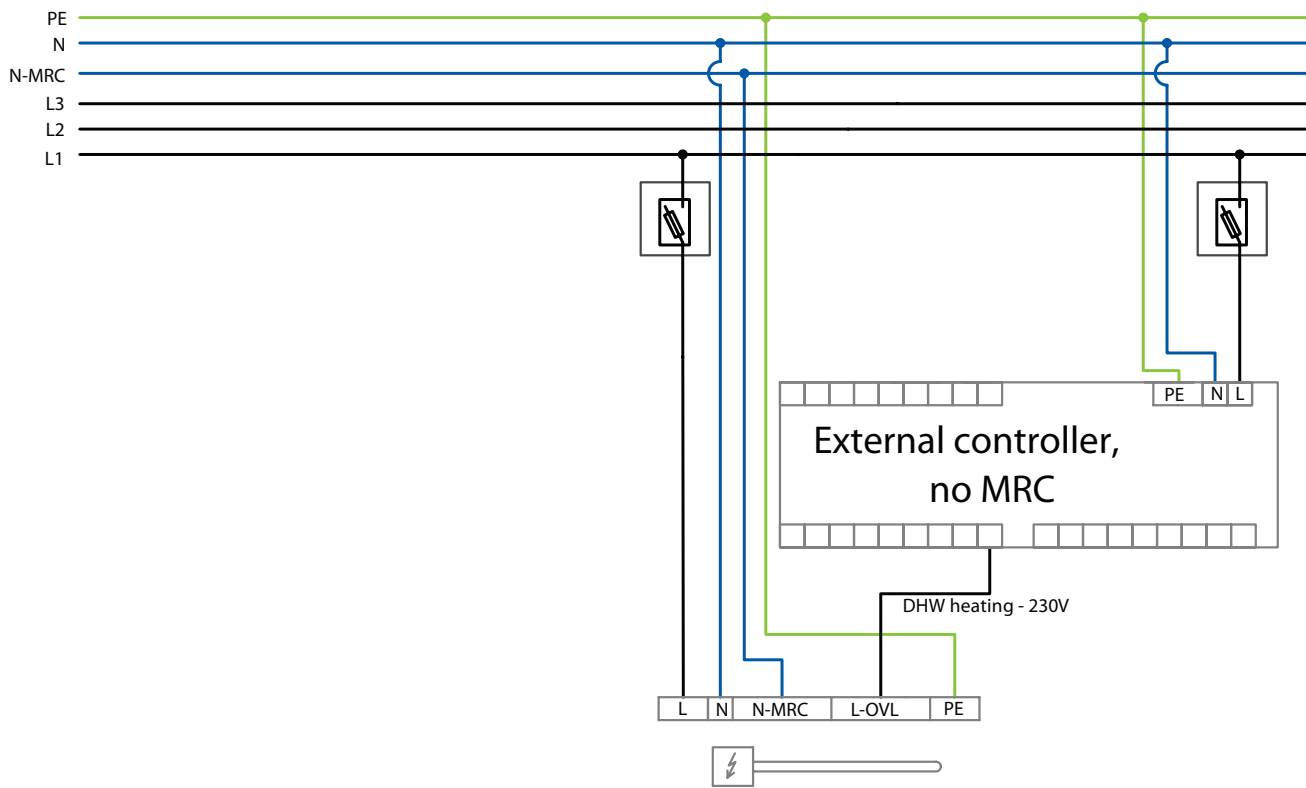

El. heating element - DHW tank

Regulus codes - 10267, 8933, 10116, 10117

System controlled with the integrated thermostat

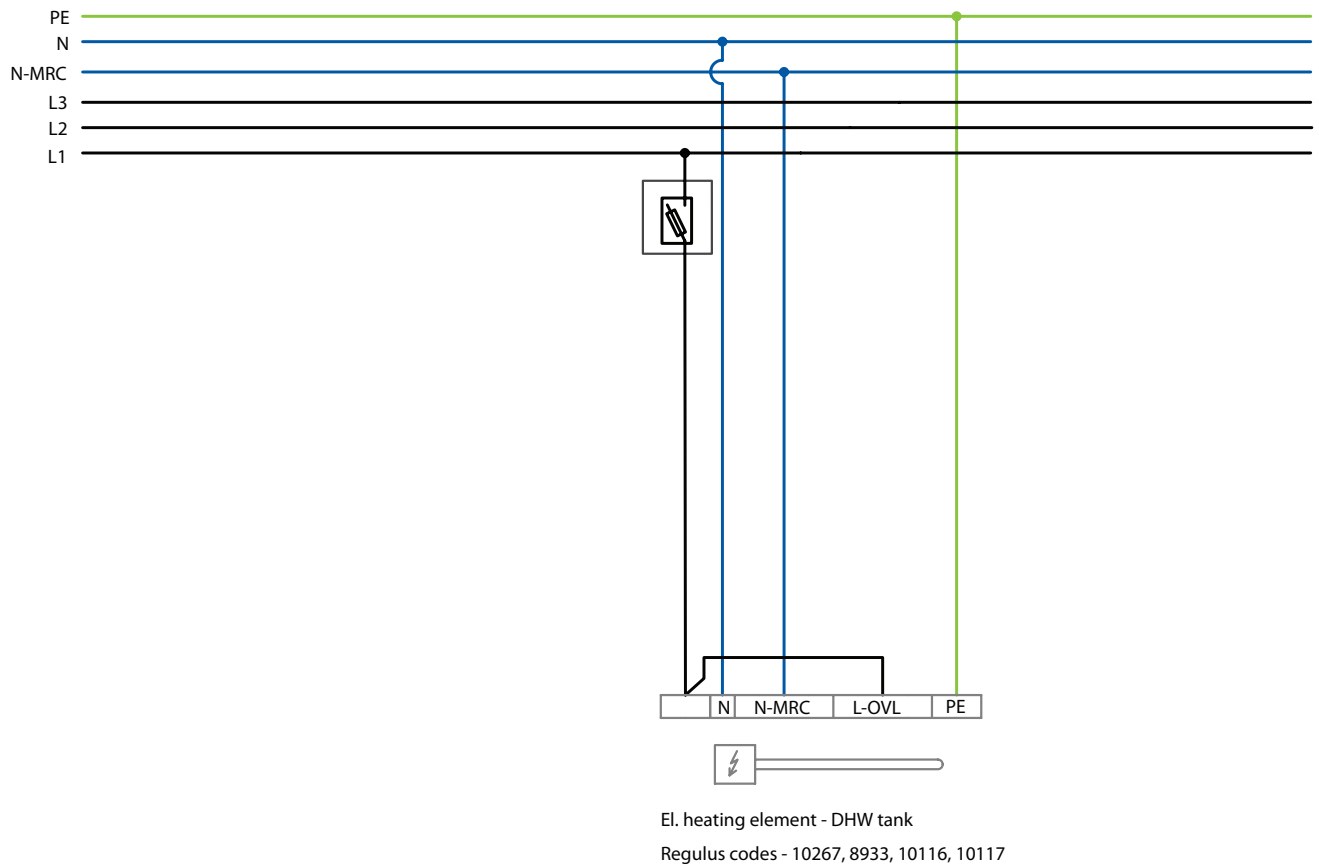

System controlled with an external controller, with MRC

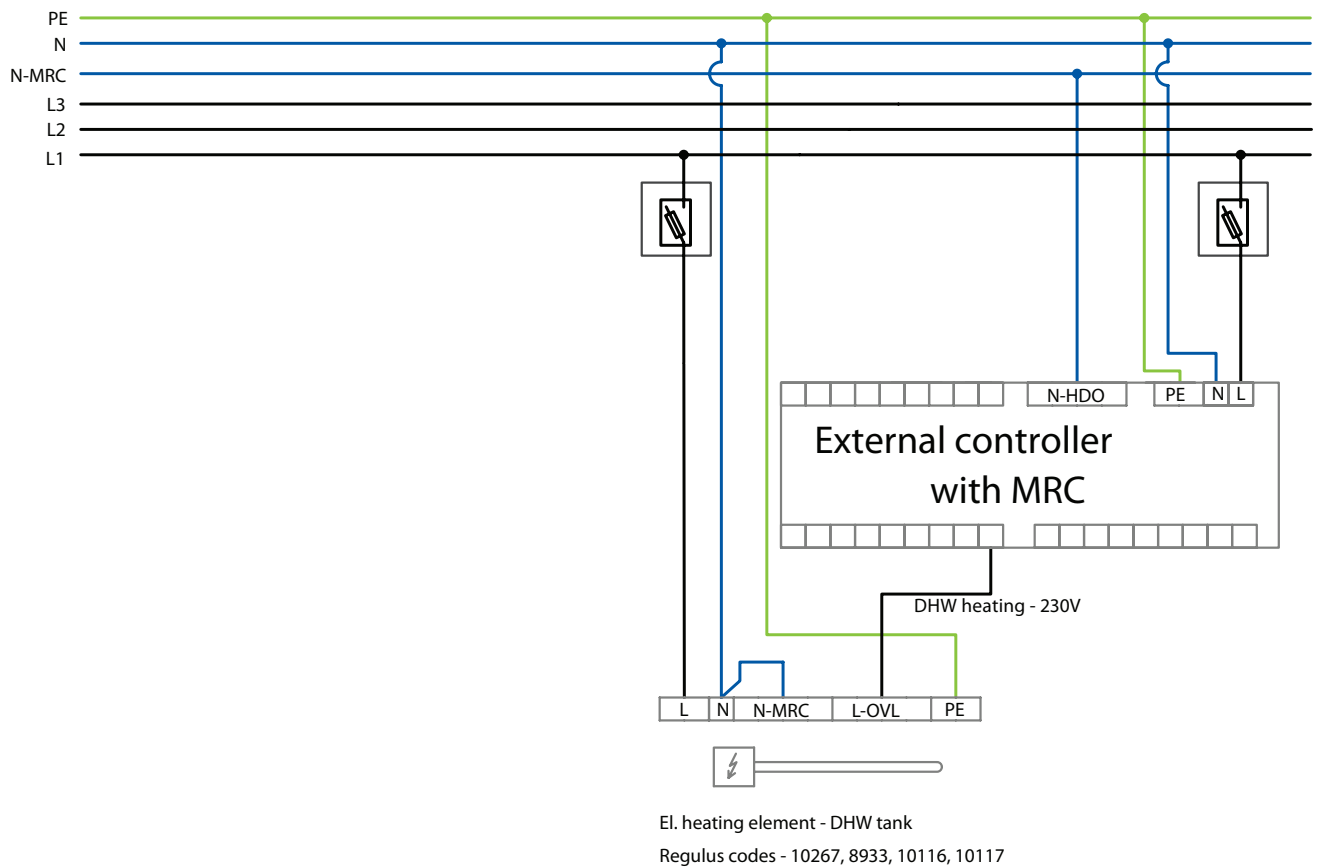

WARRANTY CERTIFICATE

Heating Element with Thermostatic Head, single phase, fixed connection

Type:

Serial number:

Shop:

Purchase date:

WARRANTY CONDITIONS

1. The warranty period is 24 months from the date of purchase.
2. The product will be installed and commissioned by a competent company or a person trained by the manufacturer.
3. When claiming warranty, this Warranty Certificate must be submitted together with the purchase receipt.
4. The warranty is valid only when the technical conditions set by the Manufacturer, installation manual and instructions in the documentation and on the product itself are maintained.
5. The warranty does not cover defects caused by external conditions or improper operation conditions, defects caused by usual wear and tear, further when the product is not used in compliance with its purpose and when the defect was caused by mechanical damage, improper handling, tampering by a third person, improper installation, improper stocking, natural disaster etc.

COMMISSIONING

Company:

Date:

Rubber stamp print and signature of the installer:

10/2010



REGULUS spol. s r.o.
Do Koutů 1897/3
CZ-143 00 Praha 4

<http://www.regulus.eu>
E-mail: sales@regulus.cz