

## DATA SHEET

### CSE2 SOL G SRS1 T P Solar Pump Station



Main Features	
Application	This twin-line solar pump station contains all components necessary for current and efficient operation. It is designed for operation with one solar consumer (e.g. hot water tank). An auxiliary electric heating element of 2–3 kW output or a gas boiler (or another switched heat source) can be connected with the pump station. Switching ON/OFF the heat source is controlled by a heating controller. The heat source must be connected to a potential-free switching contact of the controller (max. 3 kW) and must be controlled by the additional temperature sensor S3. A heating element, safety temperature limiter of the switched heat source and the S3 sensor are not included in the scope of supply.
Description	<p>The pump station includes:</p> <ul style="list-style-type: none"> <li>– UPM3 Hybrid 25-70 circulation pump,</li> <li>– SRS1 T controller,</li> <li>– check valve,</li> <li>– safety valve with G 3/4" F outlet,</li> <li>– ball valve on the supply line, 2 ball valves on the return line,</li> <li>– air eliminator with manual air vent valve,</li> <li>– flowrate indicator,</li> <li>– pressure gauge,</li> <li>– thermometers on both flow and return lines,</li> <li>– two G 3/4" M valves for filling, draining and topping up the solar thermal system,</li> <li>– G 3/4" M outlet for connecting an expansion vessel,</li> <li>– already connected temperature sensor of a solar consumer (4 m long),</li> <li>– already connected cable w. silicone insulation to connect a solar sensor (1 m long),</li> <li>– solar temperature sensor (2 m long cable),</li> <li>– already connected 230 V power cord with plug (3 m long, 3 x 1.5 mm<sup>2</sup> cross section),</li> <li>– mounting kit for installation on a wall or tank,</li> <li>– insulation.</li> </ul>
Installation	On a tank or wall.
Working fluid	Water–glycol mixture (max. 1:1).
Codes	<b>20581</b> – connections G 3/4" M, flow 2–12 l/min <b>20577</b> – connections G 1" M, flow 8–28 l/min

Pump Station Data	
Max. fluid working temperature	110 °C
Max. working pressure	6 bar
Min. system pressure	1.3 bar with the pump stopped
Ambient temperature	5 to 40 °C
Max. relative humidity	85% at 25 °C
Power supply	230 V, 50 Hz
Max. switched current	13 A/230 V
Insulation material	EPP RG 60 g/l
IP rating	IP20
Overall dimensions (w x h x d)	405 x 490 x 155 mm
Total weight	6.8 kg

# DATA SHEET

## CSE2 SOL G SRS1 T P Solar Pump Station

### Pump Station Internal Wiring

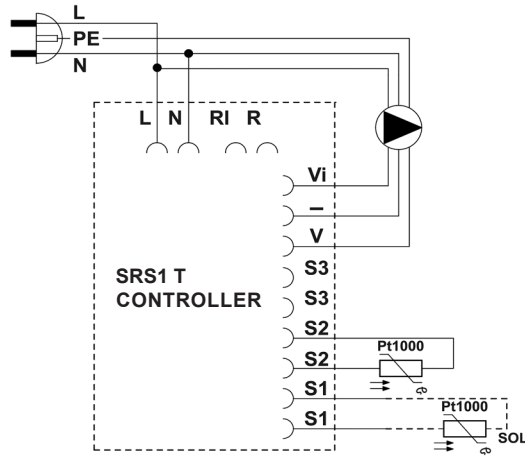

- L live
- N neutral
- RI, R potential-free switching contact
- Vi iPWM signal input
- GND PWM
- V PWM signal output
- S2 sensor 2 (solar consumer)
- S1 sensor 1 (collector)

### Pump Performance curves

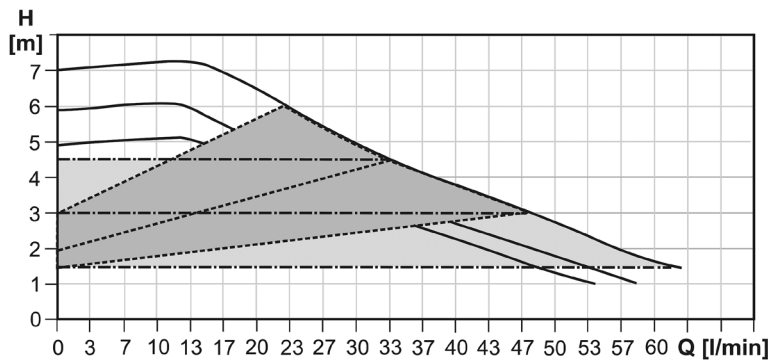

- Constant speed
- - - - - Variable pressure
- · - · - Constant pressure

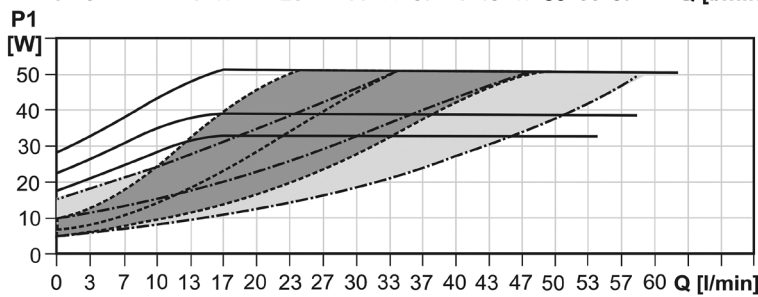

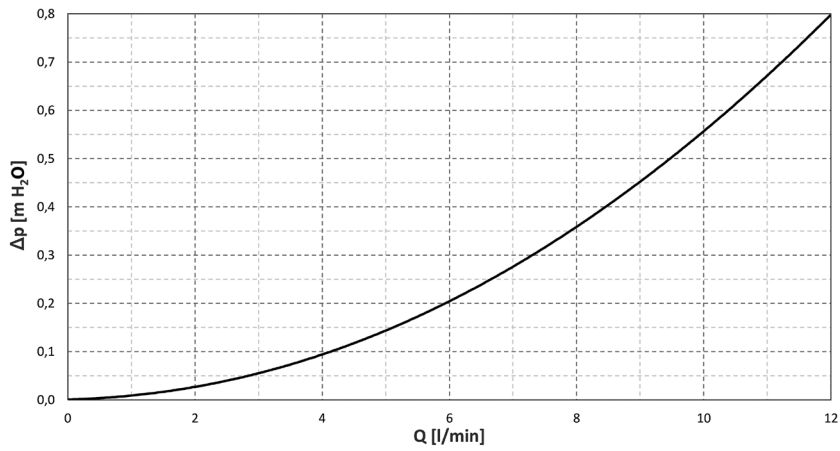
**DATA SHEET****CSE2 SOL G SRS1 T P Solar Pump Station****Pressure Drop Graph**Connections G 3/4" M – code **20581**Connections G 1" M – code **20577**