

Owners Manual

STAINLESS-STEEL
STORAGE WATER HEATERS
NBC 200 and NBC 300



CE

EN
v 1.0

Regulus

CONTENTS

1 Description	3
1.1 Models	3
1.2 Tank protection	3
1.3 Thermal insulation	3
1.4 Connection points on the tank	3
1.5 Packing	3
2 General Information	3
3 Technical Data and Dimensions of NBC Models	4
4 Operation	6
5 Examples of Assigning Connection Points	6
6 Installation and Commissioning	6
7 Tank's Insulation	9
8 Maintenance	9
9 Disposal	9
10 Warranty	9

1 - Description

NBC Storage water heater (further "tank") with one stainless steel heating coil with a G 3/4" connection (e.g. for connecting a solar system), enabling installation of an electric heating element.

In order to reach proper working of the tank, it is necessary to design optimum hydraulics of the whole system, i.e. position of circulation pumps for sources and heating circuits, valves, non-return valves etc.

1.1 - Models

Two models of 200 and 300 l capacity enabling installation of an electric heating rod or another heat source.

1.2 - Tank protection

The entire tank is manufactured of stainless steel which guarantees a long service life. Further qualitative improvement is ensured by a magnesium anode installed inside the tank.

1.3 - Thermal insulation

Tanks are supplied with a soft polyurethane insulation 50 mm thick with a white PVC surface.

1.4 - Connection points on the tank

2× lateral with G 3/4" inner thread, for the heating coil

2× lateral with G 3/4" inner thread, for cold water inlet and hot water outlet

2× lateral \varnothing 10×1 for temperature probes

1× lateral with G 3/4" inner thread, for circulation

1× top with G 1/2" inner thread, for a magnesium anode rod

1× lateral with G 6/4" inner thread, for an el. heating rod

1× lateral \varnothing 10×1 for thermometer

1.5 - Packing

Tanks are delivered standing, each screwed to its pallet, packed in bubble wrap.

2 - General Information

The appliance shall be installed by a qualified person according to valid rules and Manufacturer's Instructions.

This Owners Manual is an integral and important part of the product and must be handed over to the User.

Read carefully the instructions in this Manual as they contain important information concerning safety, installation, operation and maintenance. Keep this Manual for later reference.

Using the tank for other purposes than stated above is forbidden and the manufacturer accepts no responsibility for damage caused by improper or wrong use.

3 - Technical Data and Dimensions of NBC Storage Tanks

Regulus NBC200 Storage Water Heater
code: 8863

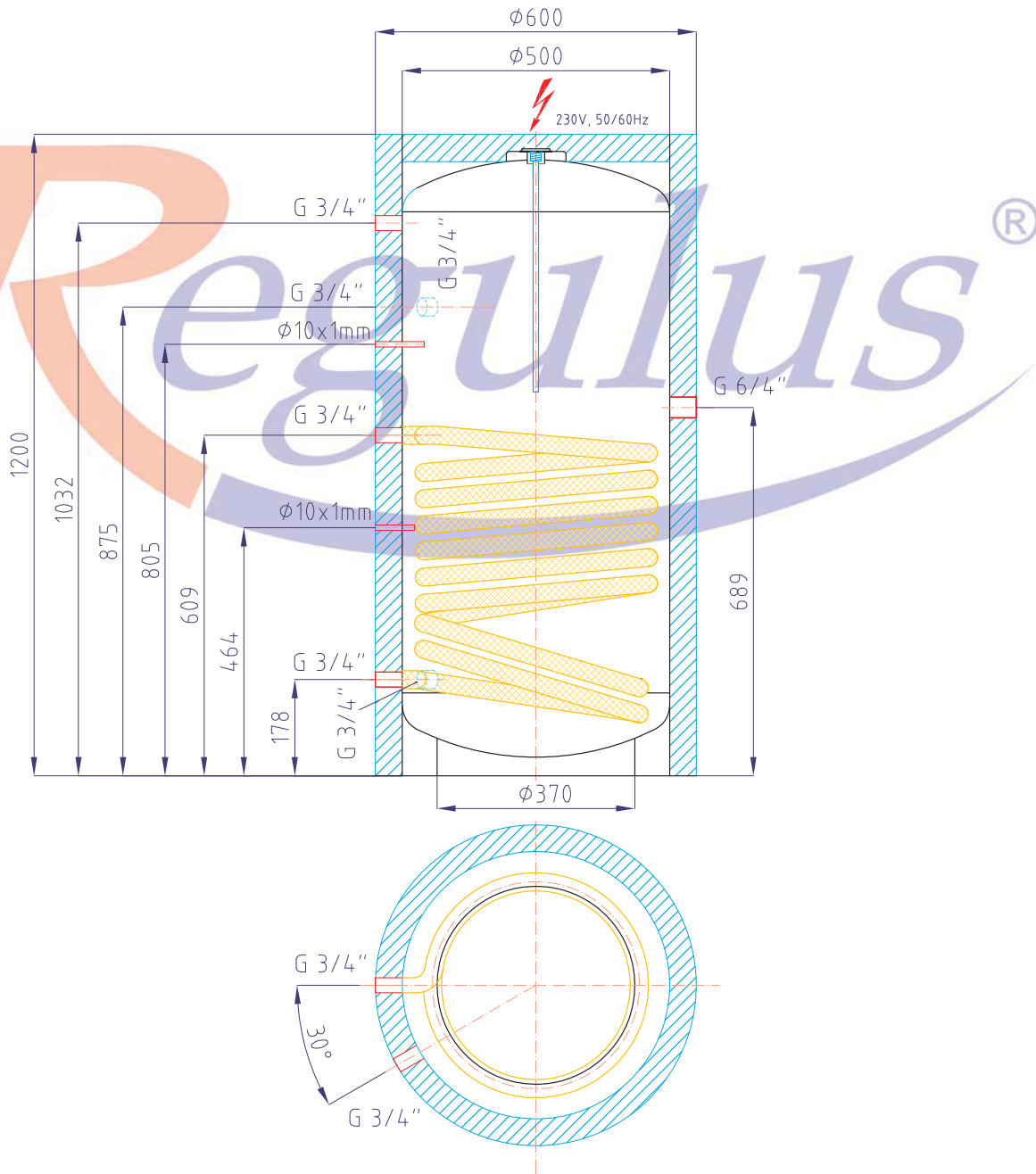

Tank total volume:	200 l
Tank material:	AISI 316L
Heating coil volume:	4.3 l
Heating coil surface:	1.0 m ²
Max. working temperature - tank:	90 °C
Max. working temperature - heating coil:	90 °C
Max. working pressure - tank:	6 bar
Max. working pressure - heating coil:	6 bar
DHW heating $\Delta t=35$ °C (80/60 - 10/45) - coil:	660 l/h (28,7 kW)
Empty weight:	36 kg

Regulus NBC300 Storage Water Heater
code: 8865

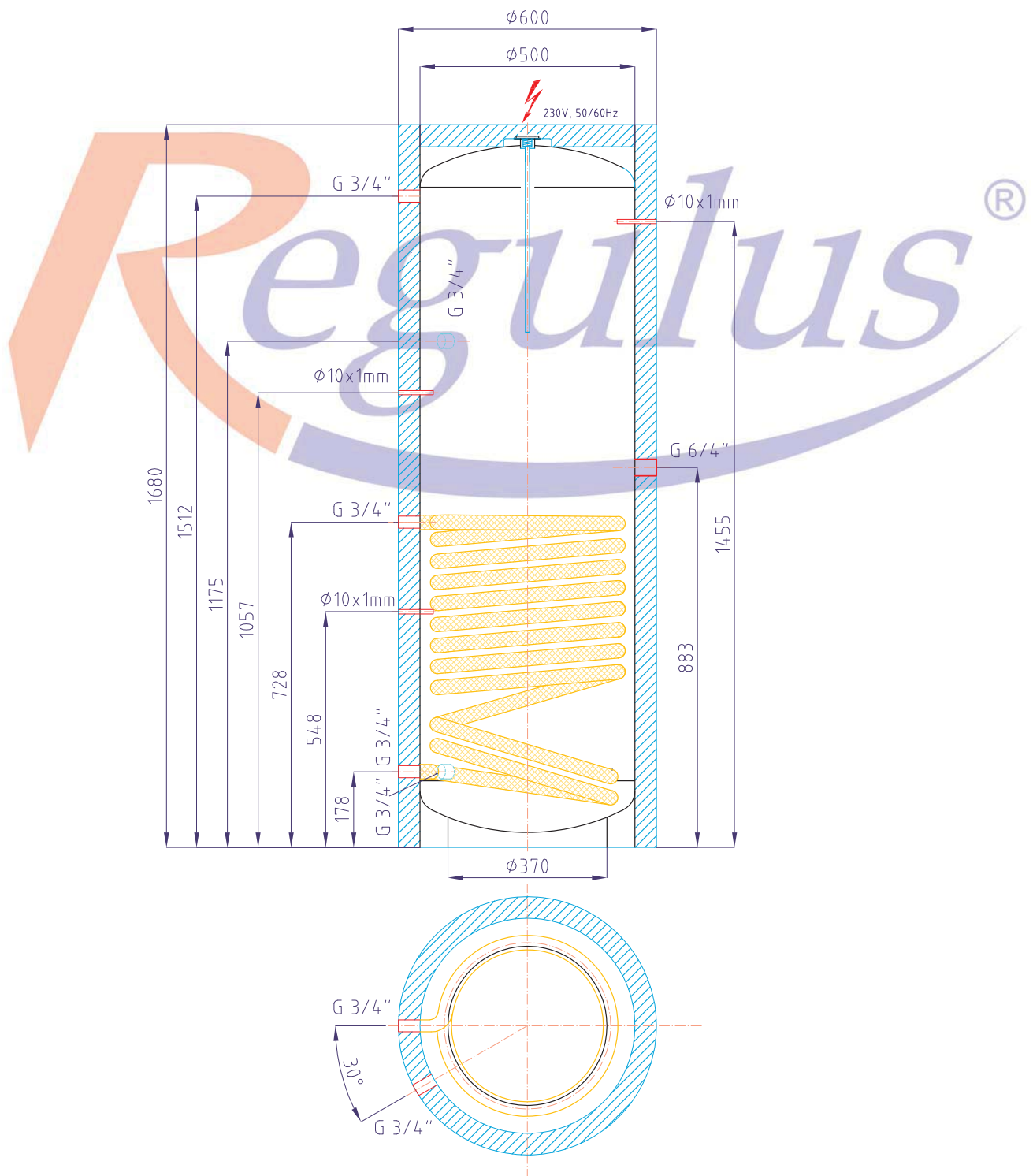

Tank total volume:	300 l
Tank material:	AISI 316L
Heating coil volume:	6.5 l
Heating coil surface:	1.5 m ²
Max. working temperature - tank:	90 °C
Max. working temperature - heating coil:	90 °C
Max. working pressure - tank:	6 bar
Max. working pressure - heating coil:	6 bar
DHW heating $\Delta t=35$ °C (80/60 - 10/45) - coil:	1000 l/h (43 kW)
Empty weight:	50 kg

4 - Operation

This tank is designed for operation in closed pressure circuits. Hot water is heated in the integrated hot-water heat exchanger (heating coil) inside the tank by several possible heat sources like various kinds of heating boilers, renewable energy sources (heat pumps, solar collectors). An electric heating rod can be installed into the tank for DHW backup heating.

Hot water temperature should be set to 60-65 °C. This temperature guarantees the best operation and at the same time, it prevents formation of Legionella bacteria.

5 - Examples of Assigning Connection Points

Example I.

With a gas boiler.

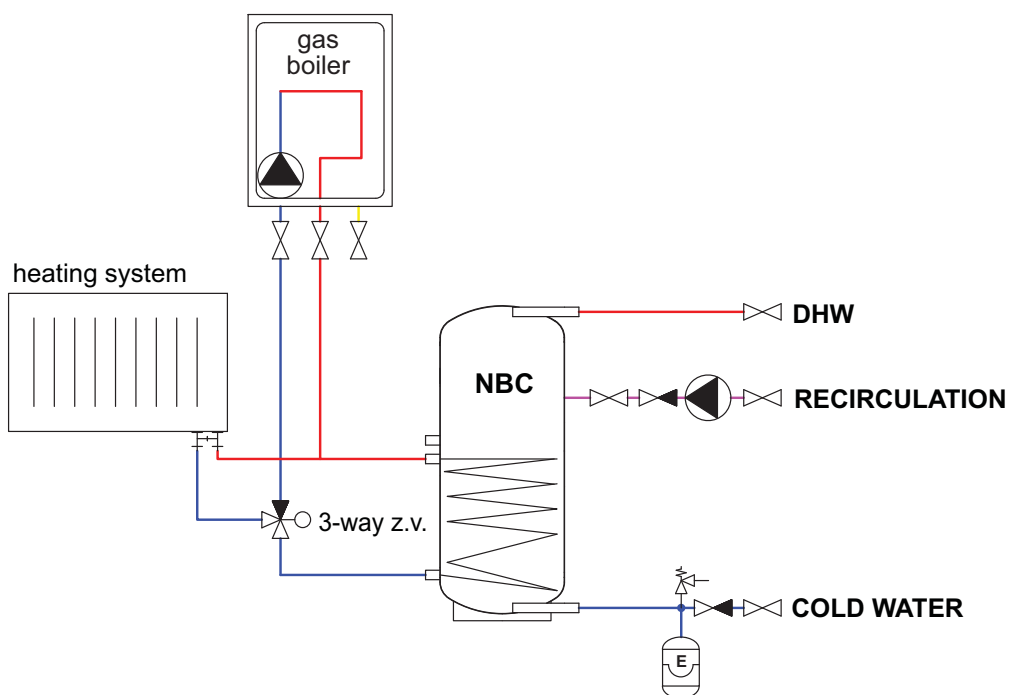

Example II.

With el. backup heating.

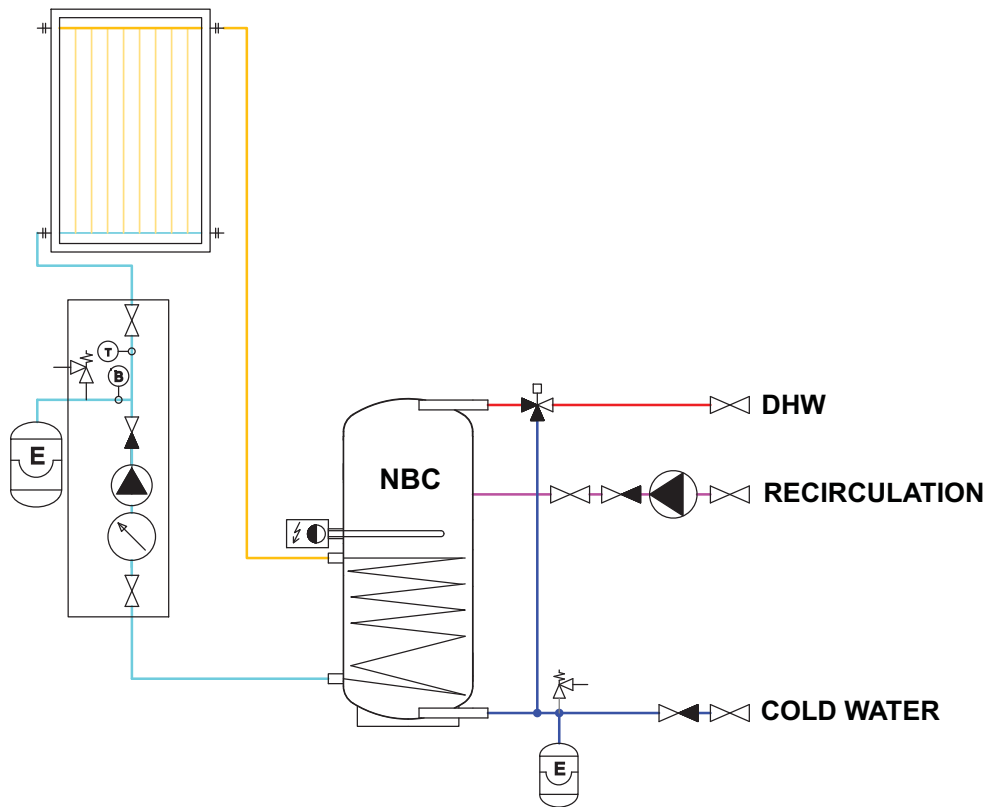

Table of limit values for total dissolved solids in hot water.

Description	pH	Total dissolved solids (TDS)	Ca	Chlorides	Mg	Na	Fe
Max. value	6.5 - 9.5	600 mg/litr	40 mg/l	100 mg/l	20 mg/l	200 mg/l	0.2 mg/l

6 - Installation and Commissioning

Installation must meet valid rules and may be done only by qualified staff. The tank shall be placed on the floor, as close to the heat source as possible.

Defects caused by improper installation, use or handling are not covered by warranty.

6.1 - Connection to heat sources

Connect heating circuits to the inlets to and outlets from heating coils. The heat source for the tank - a stainless-steel coil - connects with G 3/4" coupling.

6.2 - Connection to a solar system

The tank can be used with a solar system. In such a case, the inlet for hot heat-carrying liquid coming from the solar system shall be connected to the G 3/4" upper sleeve of the heating coil and the lower outlet to the return piping to the solar system. Insulate all the piping between the tank and the solar system.

6.3 - Heating rod installation

The G 6/4" side sleeve is designed to accommodate an electric heating rod. Heating rods of output up to 6 kW can be used (depending on the tank diameter and rod length), connected either directly to the mains (thermostat-equipped rods), or to a heating system controller. The installation may be done by qualified staff only.

Warning: Electric heating elements shall be protected by a safety thermostat.

6.4 - Connection to water mains

DHW piping shall be done according to valid rules. G 3/4" threaded couplers are used to connect the tank to a cold water inlet and hot water outlet. A 6bar safety valve shall be installed at the cold water inlet, installation of a reducing valve is recommended. If the pressure from water mains exceeds 6 bar, a reducing valve is necessary. In order to prevent water loss, an expansion tank should be installed at the cold water inlet as well (8l volume for NBC 200, 12l volume for NBC 300).

Should the water be too hard, install a water softener before the tank. In case the water contains mechanical impurities, install a strainer.

A suitable thermostatic mixing valve should be installed at the hot-water outlet from the tank, preventing too hot water from entering the taps.

Install a drain valve to the lowest point of the tank.

Complete DHW piping shall be properly insulated.

6.5 - Electronic anode installation

An electronic anode is already installed in the tank. Its advantage compared to a magnesium anode rod is a longer service life and easier check. A visual check of the electronic anode indication lamp is sufficient. Unlike with a magnesium anode rod, there is no need to take it out for check.

6.6 - Commissioning

The tank shall be earthed prior to commissioning. The earth bolt with M6 nut is located under the insulation, for access open the zipper for about 10 cm. Having connected a ground wire, close the zipper again.

Fill the heating circuits with the appropriate fluids and air-bleed the entire system. Check all connections for leaks and verify the system pressure.

The quality of top-up and heating water is set by ČSN 07 7401:1992. **Hot water quality must meet the conditions shown in the Table of limit values for total dissolved solids in hot water, page 7 of this Manual.**

Fill the heating circuits with the appropriate fluids and air-bleed the entire system. Check all connections for leaks and verify the system pressure. Set the heating controller in compliance with the documentation and manufacturer's recommendations. Check regularly a proper function of all control and adjusting elements.

7 - Thermal insulation

Description

Thermal insulation is a component of these storage tanks, preventing thermal loss. A soft polyurethane foam insulation with a PVC layer is used.

Warning

Avoid open flames near the product.

8 - Maintenance

If the tank is fitted with a heating element, disconnect it from the mains first.

Clean the exterior of the tank with a soft cloth and a mild detergent. Never use abrasive cleaners or solvents.

For the electronic anode, just a visual check of the indication lamp is necessary every 3 months. The indication of a proper function is described in a Manual for the electronic anode.

If damage to a tank occurs due to a non-working electronic anode, the warranty cannot be claimed.

9 - Disposal

Packing shall be disposed of in compliance with the valid rules. When the product reaches the end of its life, it shall not be disposed of as household waste. It shall be recycled. Insulation shall be recycled as plastic and the steel vessel as scrap iron.

10 - Warranty

This product is covered by warranty according to the conditions described in this Manual and according to the Warranty Certificate. A Warranty Certificate is an integral part of the supply.



REGULUS spol. s r.o.
Do Koutů 1897/3
143 00 Praha 4

<http://www.regulus.eu>
E-mail: sales@regulus.cz