

Installation and Operation Manual

Solar System with KPS11+ Collectors



CE

EN
v. 1.1

Regulus

CONTENTS

General Installation and Operation Instructions	3
1 Supply of Mounting System	4
2 Sloping Roof Mount	5
2.1 Preparation	6
2.1.1 Installation with roof anchors and auxiliary boards	6
2.1.2 Installation with roof anchors and rafters	6
2.1.3 Installation with roof anchors for slate, shingle or metal roofs	7
2.1.4 Installation with bolts for fixing rails onto a roof	7
2.2 Installing rails onto roof anchors	9
2.3 Collector mounting	9
3 Connection Pipe Passage through a Roof	10
4 Flat Roof Mount	11
4.1 Overview	11
4.2 Flat roof support mounting	12
5 Hydraulic Connection	15
5.1 Collector connecting	14
5.2 Collector interconnecting	14
6 Temperature Probe Positioning	16
7 Pump Station	17
8 Expansion Vessel Sizing and Working Pressure Calculation	18
8.1 Expansion vessel sizing	18
8.2 Calculation of a system working pressure	18
8.3 Calculation of an expansion vessel preset pressure	18
8.4 Examples of calculating working pressure and expansion vessel pressure	18
8.4.1 Example of calculating system working pressure	18
8.4.2 Example of calculating expansion vessel pressure	18
9 Installation of Air Release Valves	19
10 System Filling, Flushing, Leak Test and Air Bleeding	20
10.1 Filling	20
10.2 Flushing	20
10.3 Air bleeding	20
10.4 Leak test	20
11 Commissioning	21
12 Operation, Checks and Maintenance	21
13 Servicing and Warranty	21
14 Technical Data	22
15 Connection dimensions.....	24
16 Annual Check Description	25
17 Service Sheet	26

GENERAL INSTALLATION AND OPERATION INSTRUCTIONS

Collector description

REGULUS KPS11+ Flat Plate Solar Collectors are designed for solar domestic hot water heating (DHW), backup- and pool heating with solar energy. Solar radiation penetrates the glass and is intercepted by an efficient absorption layer applied on an aluminum absorber. The heat is then transferred into heat transfer fluid. The absorber is sealed in a compact frame with high quality thermal insulation. The collectors are designed for year round operation, that's why they work in a separate primary circuit filled with antifreeze heat carrier.



The collectors are **not intended** for direct water heating. If different heat transfer fluid is used than specified by the manufacturer, irreversible damage to the collector may be done.

Transport, handling and storing

Collectors shall be transported in their original packing, in upright position (standing on their shorter side) or lying horizontal with glass upwards, stack of max. 10 pieces on a pallet.

During handling the collector glass shall be always facing upwards.

Please check the condition of the collector upon reception from your supplier or forwarder. Later claimed mechanical damage (frame, glass, connection) will be refused.

When stored, the collector shall not be exposed to rain and its absorber exposed to solar radiation.

Scope of supply

1. KPS11+ Collector
2. Instruction manual
3. Warranty Certificate
4. Commissioning form - info for the Manufacturer

General instructions for installation

The installation must be done by a trained worker or a specialized company.

During installation and before commissioning, it is necessary to cover collectors in order to avoid overheating and possible burn injury to the installer.

Prior to installation, conditions set by the roofing manufacturer and the max. permissible roof load shall be checked.

Mounting method for solar collectors shall always respect local conditions, i.e. roof inclination and weather influence on the overall load on the collector. Kindly consult the fixing method with a structural statics expert.

During installation the collectors and accessories shall be handled carefully. Defects caused by improper handling or DIY installation are not covered by warranty.

Generally valid rules and standards for occupational safety shall be respected during installation. This concerns mainly technicians walking on a roof and the se-

curing the area against objects falling down from a roof. Only REGULUS fixing elements may be used. Other fixing elements may be used only with a written approval from REGULUS company.

Collectors shall not be exposed to solar radiation until commissioned. The absorption surface may get damaged.

Collectors shall be installed and operated in compliance with this Manual and with respective generally valid rules and norms.

Collector placing

The collector must be placed outdoors. The glass absorption surface should be orientated to South, with deviations not over 45° (Southwest or Southeast). For a year round operation the right inclination angle is 40°-50°, for summer operation smaller inclination is better (30°). The collector may be placed also vertically (90° inclination, e.g. on an outer wall) .



Collectors shall be installed as marked.

A collector inclination shall not be less than 20°.

On inclined roofs it is recommended to install solar collectors as close to the roof ridge as possible. Should this solution be impossible, then protections against snow slide shall be installed above the collectors.

The numbers of roof anchors shown in the Mounting Kits for Fixing and Connecting Regulus Solar Collectors are designed for the following load:

Max. permissible snow and wind load $\leq 1,8 \text{ kN/m}^2$

Max. permissible wind load - negative pressure $\leq 1,0 \text{ kN/m}^2$



$\leq 1,8 \text{ kN/m}^2$

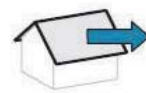



$\leq 1,00 \text{ kN/m}^2$

The customer/user shall be informed about this fact prior to starting installation of a solar system. If a higher load than shown above is expected in the area in question, a statics expert shall be consulted and more roof anchors designed, or other measures taken that would ensure safe collector fixing. Regulus refuses any responsibility for damage caused by wrong design of collector fixing.

1. DELIVERY OF MOUNTING SYSTEM

Mounting kits for fixing and connecting KPS11+ solar collectors		Code
	Connection kit for a KPC, KPS, KPG and KPH (G3/4" M inlet and outlet, 2 plugs, G3/8" for air vent valve, sheath for solar temperature sensor)	7710
	Fixing kit for one KPS11+ collector *[for 4 anchors or 2 supports+1 strut]	12184
	Fixing and interconnection kit for 2 KPS11+ collectors *[for 6 anchors or 3 supports+1 strut]	12185
	Fixing and interconnection kit for 3 KPS11+ collectors *[for 8 anchors or 4 supports+1 strut]	12186
	Fixing and interconnection kit for 4 KPS11+ collectors *[for 10 anchors or 5 supports+1 strut]	12187
<p>* Roof fixing and interconnecting kits are necessary to create a hydraulically connected collector array fixed to 2 mounting rails. The kits contain interconnecting fittings with insulation, two mounting rails, fastening material for mounting collectors onto the rails. They do not involve any roof anchors, supports, struts. These shall be selected from the following chart by the roof type and roofing material.</p>		

Supports and struts for flat and sloping roof installation		Code
	Triangle support strut 15°	11979
	Triangle support strut 25°	10975
	Triangle support strut 45°	6859
	Strut incl. screws for triangle support	9563

Supports for sloping roof installation		Code
	Triangle strut 15° for sloping roofs	10748
	Triangle strut 25° for sloping roofs	8805
	Triangle strut 45° for sloping roofs	10094
	Triangle strut 60° for sloping roofs	9631

Anchors for various roofing types		Code
	Stainless steel anchor for slate roofs	11574
	Aluminum anchor for pantiles - adjustable height	7013
	Anchor for pantiles - hot-dip galvanized steel	7929
	Aluminum anchor for pantiles - rafter mounted	6932
	Stainless-steel anchor for pantiles	6857
	Stainless steel anchor for pantiles - rafter mounted, incl. self tapping screws	10159
	Bolt for fixing rails onto a roof	7320

2. SLOPING ROOF MOUNT

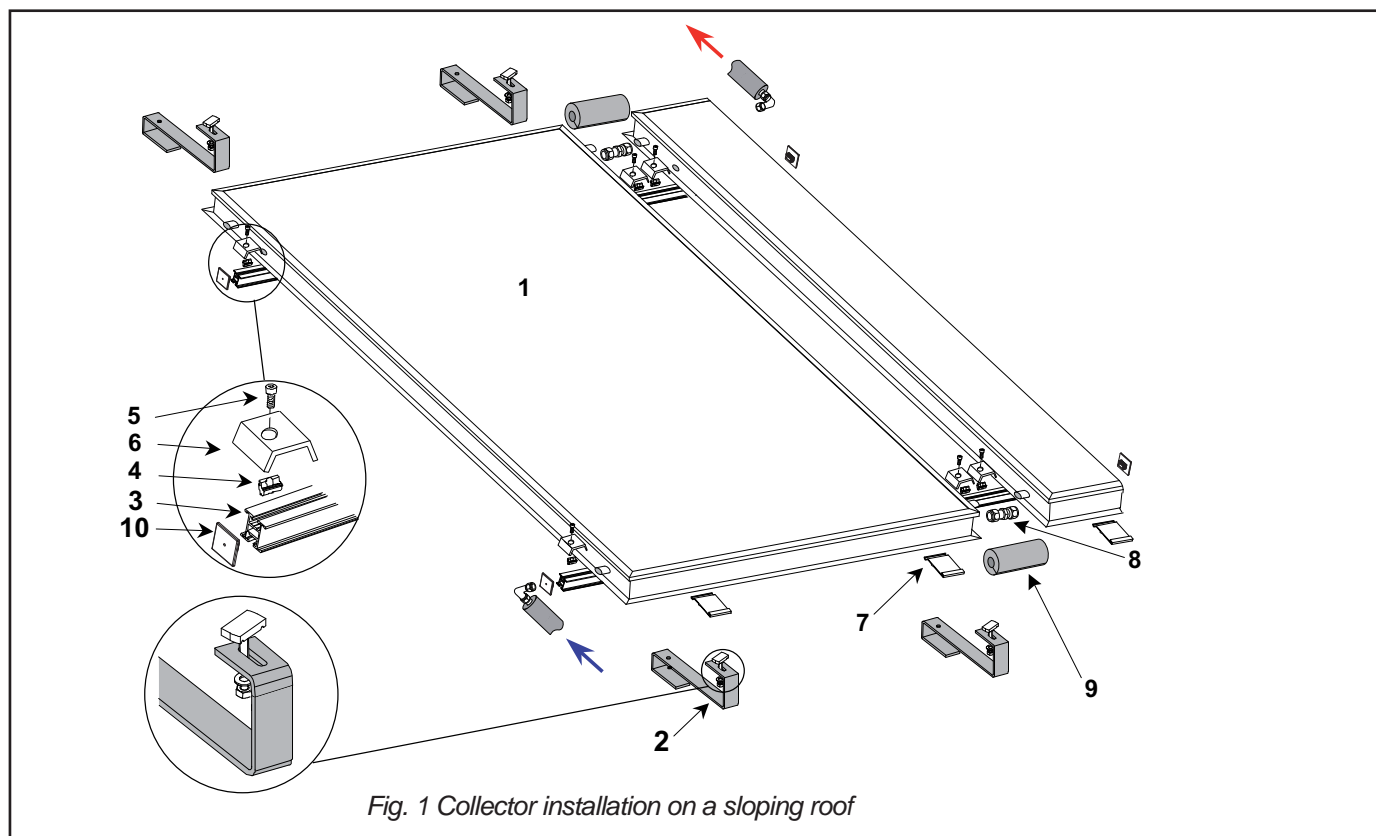

Pos.	Item	Code
1	Flat plate collector	10646
2	Roof anchor with M8 bolt/special head for rails	6857 or other, depending on roofing type
	Triangle brackets for inclination adjustment, suitable for anchors for sloping roofs - 15°, 25°, 45° and 60° angle	11748, 8805, 10094, 9631
	Interconnecting pipes	

Fixing and interconnection kits						
		No. of collectors (kit code)				Item code
		1	2	3	4	
		(12184)	(12185)	(12186)	(12187)	
3	Aluminum rail, 2 pieces	1.32 m	2.6 m	3.9 m	5.18 m	6949
4	M8 nut for the rails	4 pcs	8 pcs	12 pcs	16 pcs	6925
5	M8 ×20 bolt with allen head	4 pcs	8 pcs	12 pcs	16 pcs	12136
6	Retaining side bracket	4 pcs	8 pcs	12 pcs	16 pcs	12141
7	Retaining bracket for collector bottom	2 pcs	4 pcs	6 pcs	8 pcs	11690
8	Compression nut and ring for collector interconnection	-	2 pcs	4 pcs	6 pcs	7629
9	Insulation 35 mm diam., 19 mm thick	0.8 m	1 m	1.5 m	2 m	7188
10	Rail end plug	4 pcs	4 pcs	4 pcs	4 pcs	11773
	Insulation tape	0.8 m	1 m	1.5 m	2 m	7227

Expansion mount and interconnection kits for 1 KPS11+ solar collector	Code
Expansion mount and interconnection kit for 1 KPS11+ solar collector	12188

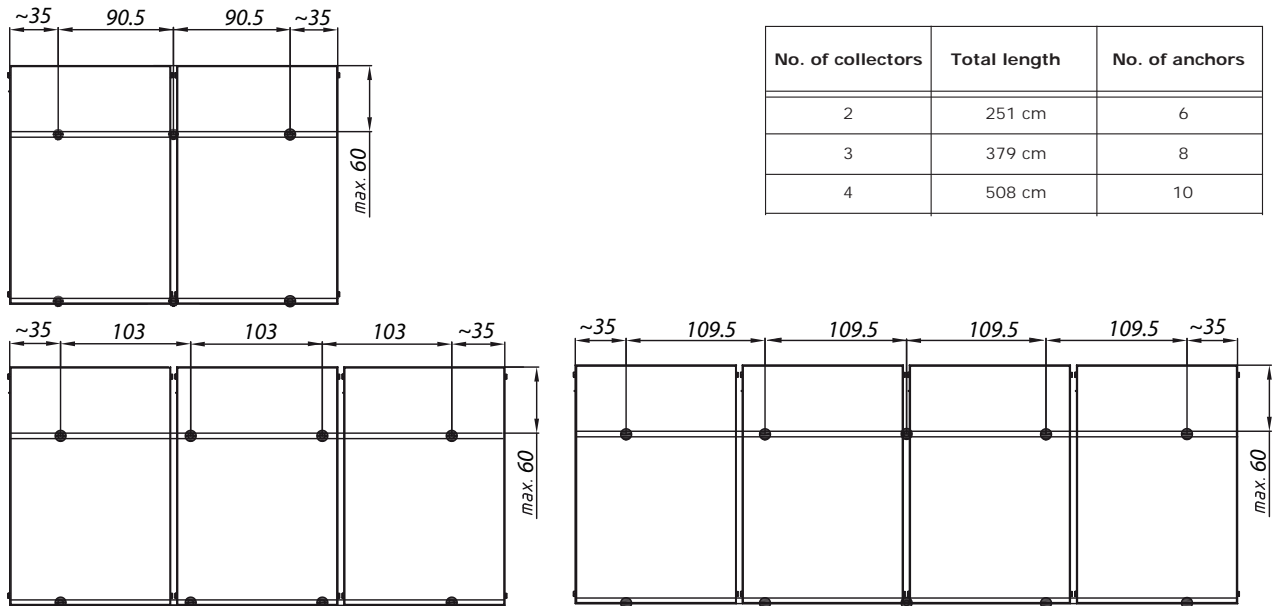

Fig. 2: Layout of roof anchors

2.1 Prior to installation

Prior to installation of solar collectors, select a suitable position respecting the following conditions:

- roof facing South
- roof inclination (25° - 45°)
- unshaded place
- accessible for servicing
- permissible roof load
- shortest possible distance between the collectors and (accumulation) tank

Further have ready the necessary material, tools and safety equipment for working on a roof.

Check if the roofing manufacturer offers roof hooks and if the roof warranty will not be violated.

2.1.1 Installation with roof anchors and auxiliary boards

Prior to installing anchors on auxiliary boards, the following shall be ensured:

- The auxiliary board length shall exceed the length of the rail by at least 200 mm at each end.
- The auxiliary board width shall be between 100 and 200 mm.
- It shall be 30 mm thick.
- The height of the auxiliary board from the counter batten shall be equal to the batten thickness which can be reached by underlying the auxiliary board (see Fig. 3).

Installation

- Remove roofing so that auxiliary boards can be inserted (approx. distance between boards 1600-1800 mm). For roof tiles, just shifting them upwards in the length of the auxiliary board is sufficient (see Fig. 4).
- Fix the auxiliary boards to battens so that the distribution of anchors resembles the positions in Fig. 2. At the same time screw the boards so high that the roof anchor does not hinder placing the roof tile with the

right overlap (see Fig. 8).

- Hang the roof anchors onto the auxiliary board respecting their distribution shown in Fig. 2.
- Fix the anchors using stainless steel screws.

2.1.2 Installation with roof anchors for rafters

For tiled roofs, rafter anchors can be used. Either a fixed (not adjustable) stainless-steel hook (Fig.7a) can be used, or an adjustable aluminum anchor (Fig. 7b) that enables horizontal shift of the anchor along the fixing board. For this anchor type also the rail fixing height can be adjusted.

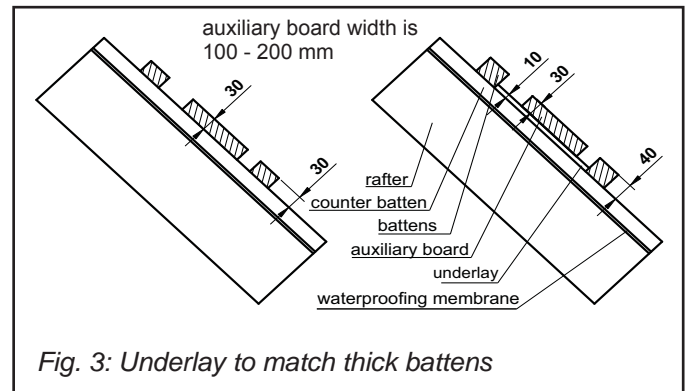

Fig. 3: Underlay to match thick battens

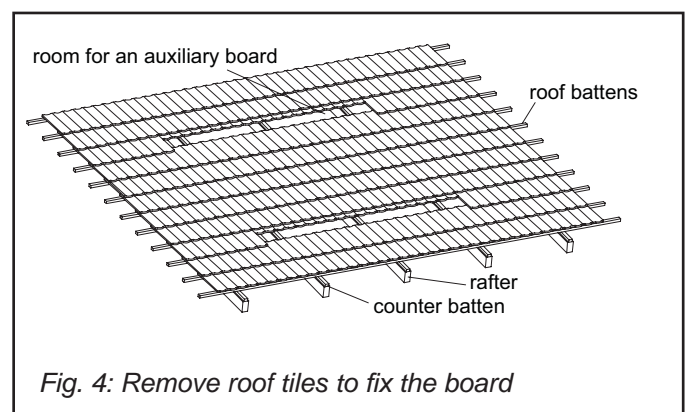

Fig. 4: Remove roof tiles to fix the board

Installation

- Remove roofing in places where anchors shall be fixed (Fig. 5). The distance "a" between anchors is defined in Fig. 2.
- Cut the counter batten used for fixing the waterproofing membrane.
- Prior to the installation itself, use an underlay for anchors according to the thickness of battens and counter battens so that the anchors installed do not hinder proper positioning of the roof tiles.
- Screw the adjustable aluminum anchor to a rafter and move it in the groove horizontally so that it doesn't hinder proper positioning of the roof tile. If a fixed stainless steel anchor is used, its position shall be adjusted before fixing.
- Fix all the other roof anchors in the same way.
- When installing roof anchors, maintain a direction parallel to the roofing (horizontal).

2.1.3 Installation with roof anchors for shingle or metal roofs

- Depending on the number of collectors, measure and calculate the positions for fixing roof anchors (Fig. 2). Such places shall be selected for mounting where anchors can be fixed sufficiently into the roof frame (rafter or similar).
- Prior to fixing the anchor, apply suitable silicone putty on the contact surface (adjacent to the roofing) in order to prevent water leaking, or possibly use a sealing method recommended by the roofing manufacturer.
- Simply lay the anchor onto the roof tiles and fix it with stainless-steel bolts.



If the roofing is made of e.g. copper or zinc-plated iron, then the anchor contact surface shall be isolated using suitable underlay (rubber). Otherwise there is a risk of contact corrosion.

2.1.4 Installation using bolts for fixing rails onto a roof

This method of installation is preferably used for roofs of bitumen corrugated sheets like Gutta or Onduline etc., or for corrugated eternit or metal sheets.

Installation:

- Depending on the number of collectors, locate the places for drilling holes and installing bolts into the roofing (Fig. 6f). Pre-drill 6 mm diam. holes into a rafter or another massive wooden roof element for the bolts.



Holes should be always drilled in the crest of the roofing wave, not in its valley, to avoid leakage.

- The hanger bolt shall be screwed with its screw end into a rafter or another massive wooden roof element using spanner No. 7.
- After screwing the hanger bolt in, put on the rubber seal (Fig. 6f) and using a washer and nut, seal the drilled hole.
- Then mount the U-shaped bracket (Fig. 9) on the bolt, between two nuts with a split lock washer.
- Then M8 bolt with floating head (for rails) shall be mounted into the other end of the bracket. First insert the floating head into the groove of the rail, and then tighten the bolt together with the rail to the U-shaped bracket using a nut and a serrated washer.

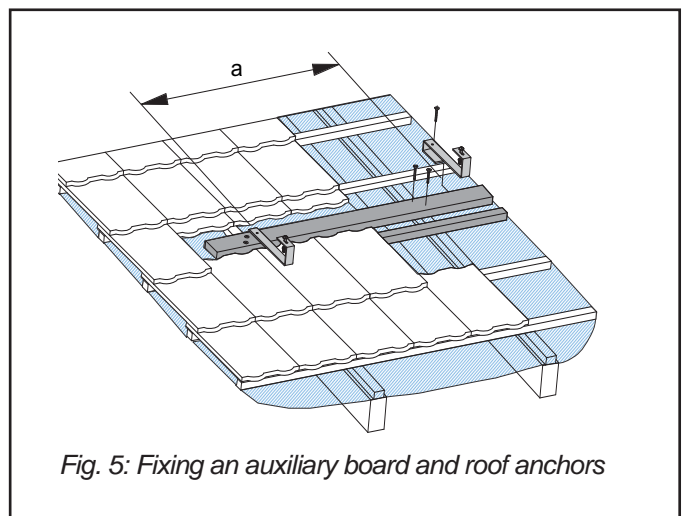

Fig. 5: Fixing an auxiliary board and roof anchors

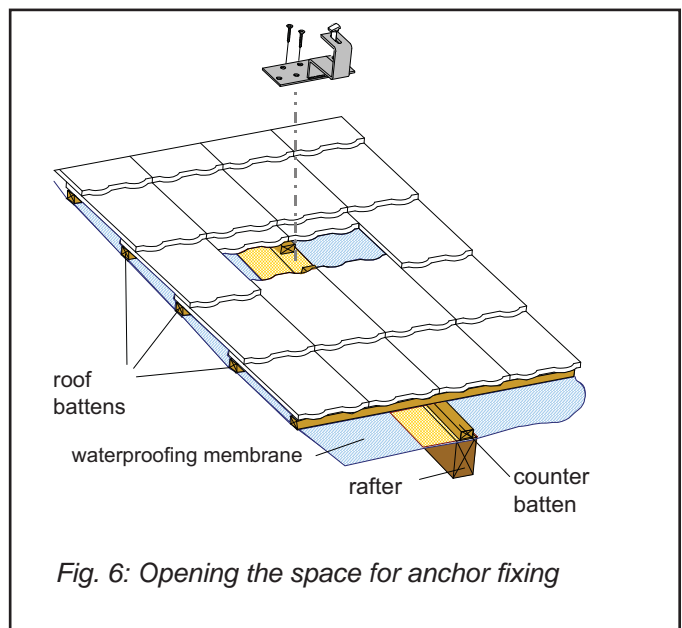
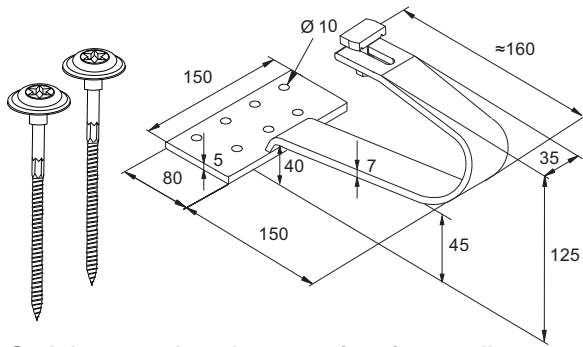
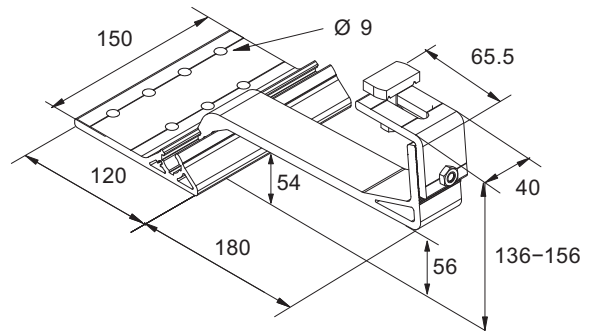

Fig. 6: Opening the space for anchor fixing



a) Stainless steel anchor on rafter, for pantiles, incl. screws



b) Aluminum anchor on rafter, for pantiles

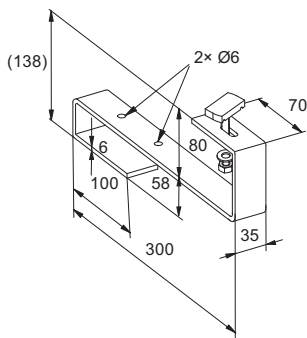

c) Roof anchor of stainless steel or zinc-plated steel for pantiles

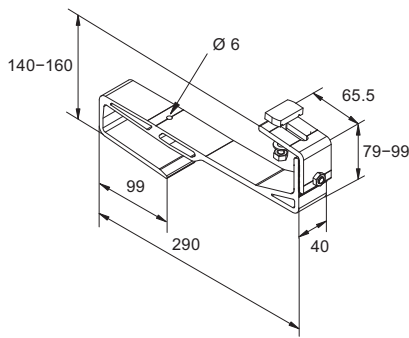

d) Aluminum roof anchor for pantiles, adjustable height

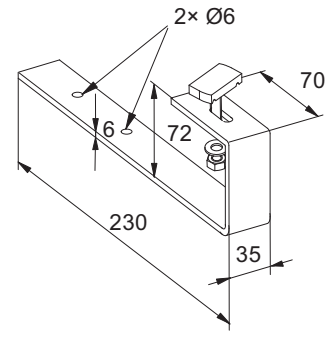

e) Stainless steel roof anchor for metal or slate roofing

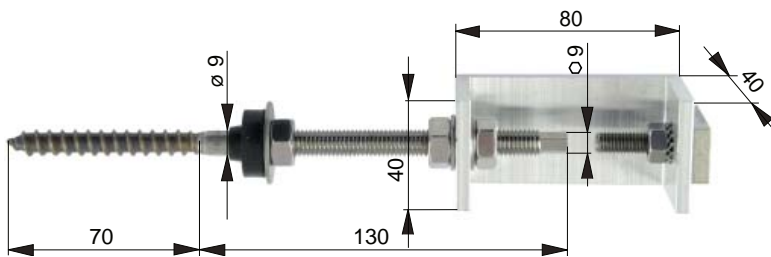

f) Hanger bolt for rail fixing

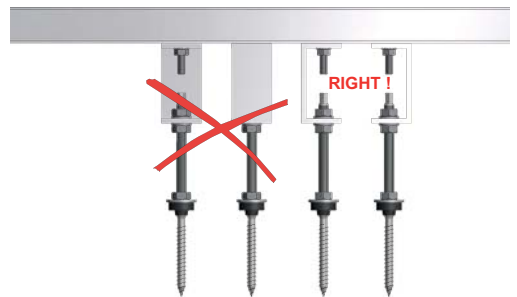

Fig. 7: Basic overview of fixing elements

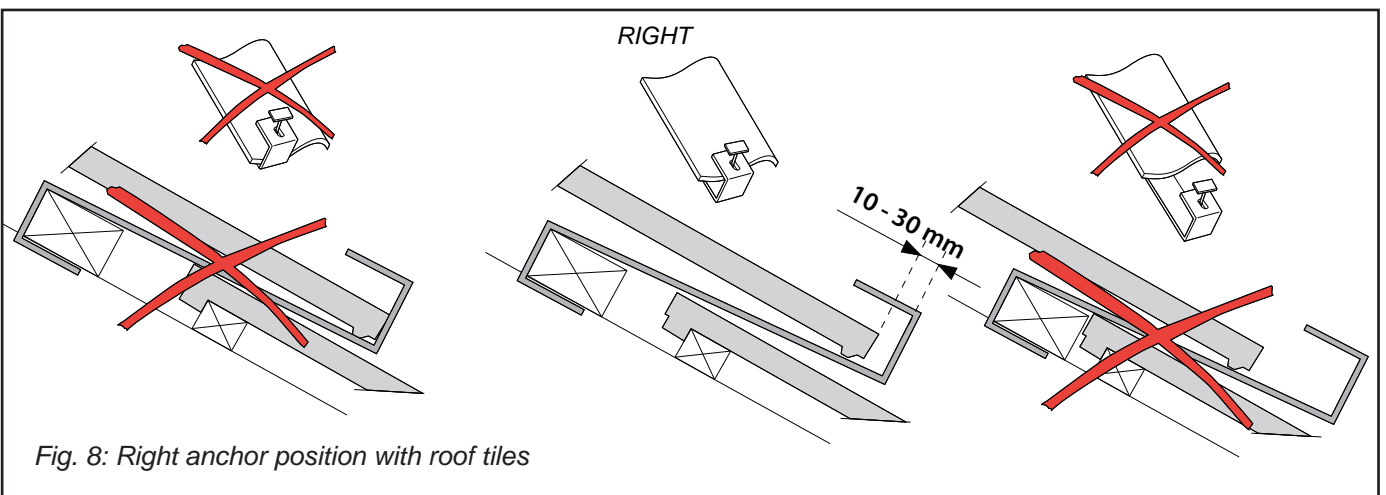

Fig. 8: Right anchor position with roof tiles

2.2 Fixing rails on roof anchors

- Have ready two rails in the length required for the number and type of collectors to be installed.
- Align the travelling screw head (Fig. 9) with the horizontal rail and shift the rail onto it, or shift the bolts into the rail first and fix to the anchors. Use serrated lock washers to fix the nuts.
- Align the rails so that they lie in parallel to roof tiles. The diagonals between the rails must be of the same length: $D1 = D2$ (Fig. 10).
- Then tighten the nuts on fixing bolts.

2.3 Collector mounting



Collectors shall be covered during mounting.

Installation:

- Insert safety retaining brackets (Fig. 11) into the bottom rail, 2 brackets per collector.
- Insert the retaining brackets into the bottom rail about 100 mm from the collector edge.
- Lay the first collector carefully on the rails and align it in the brackets.



Collectors shall be placed on the rails with marking upwards. The distance between the bottom edge of the collector and of the base rail depends on the design and size of the retaining brackets. The collector bottom edge is by circa 75 mm lower.

- The distance between the collector edge and the end of the bottom rail is $B = 35$ mm (Fig. 12).

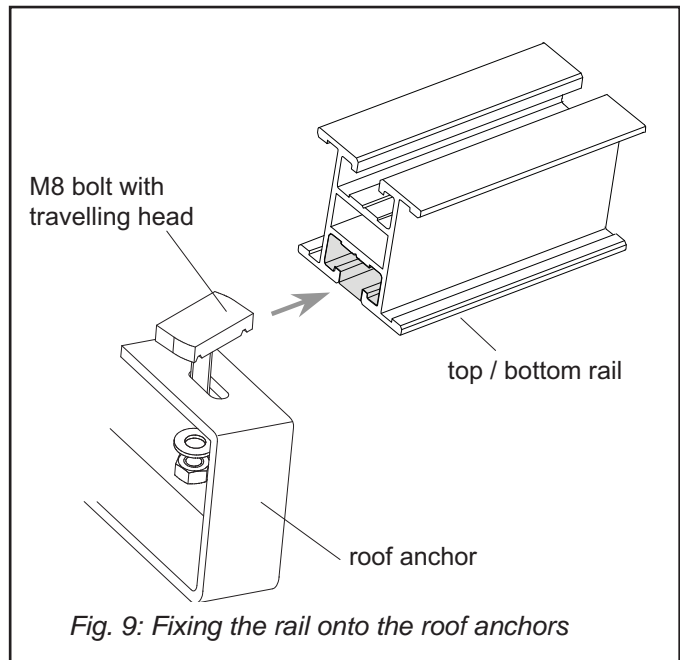

Fig. 9: Fixing the rail onto the roof anchors

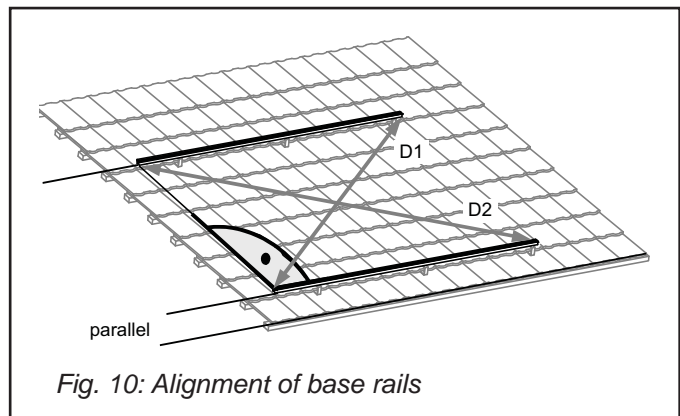

Fig. 10: Alignment of base rails

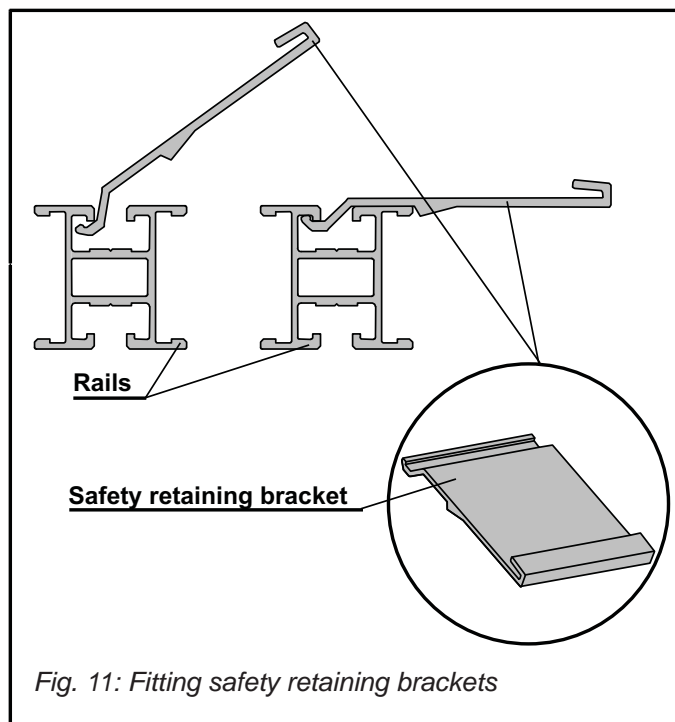

Fig. 11: Fitting safety retaining brackets

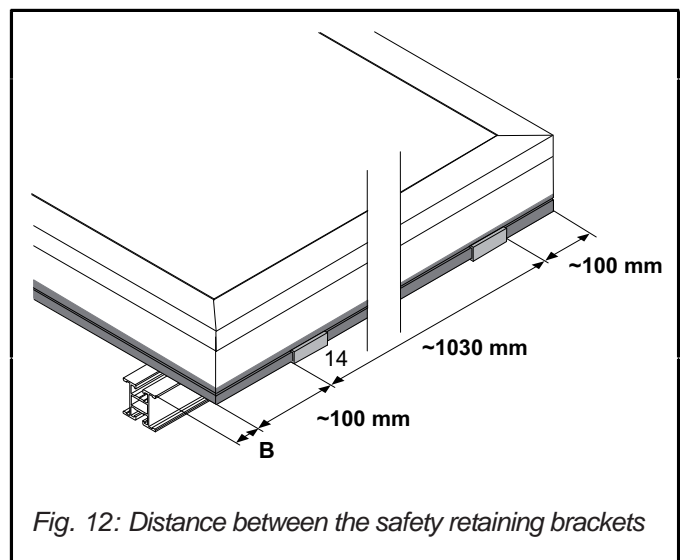
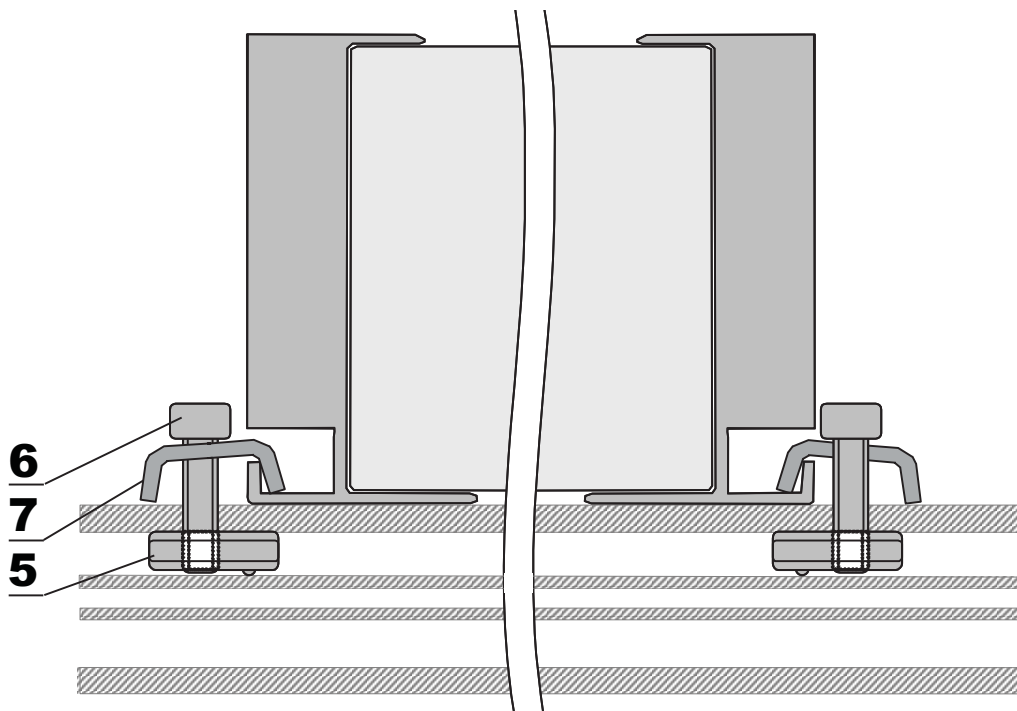

Fig. 12: Distance between the safety retaining brackets



- 5 – M8 nut for rail
- 6 – M8x20 allen head bolt
- 7 – Retaining bracket

Fig. 13: Fixing the retaining brackets

- Insert nuts into both the rails (Fig. 13). Put the retaining side brackets on the rails and fix the collector using M8x20 bolts.
- Lay the following collector next to the first one, maintaining a sufficient gap. Then put on the threaded fittings (Fig. 14, pos. 9) and push the collector to the already mounted one until stop. Hold the fitting with a spanner to prevent turning and tighten the nuts. More on this in chapter 5 **Hydraulic Connection**.
- Continue mounting further collectors in the same way (see page 15).

3. CONNECTION PIPE PASSAGE THROUGH A ROOF

For passing the connection pipes through a roof e.g. ventilation tiles can be used, where the hole is modified according to the diameter of the pipe with insulation. Anyway standards of the roofing manufacturer shall be respected for pipe passage through a roof.



Fig. 13b: Pipe passing through ventilation tile

4. FLAT ROOF MOUNT

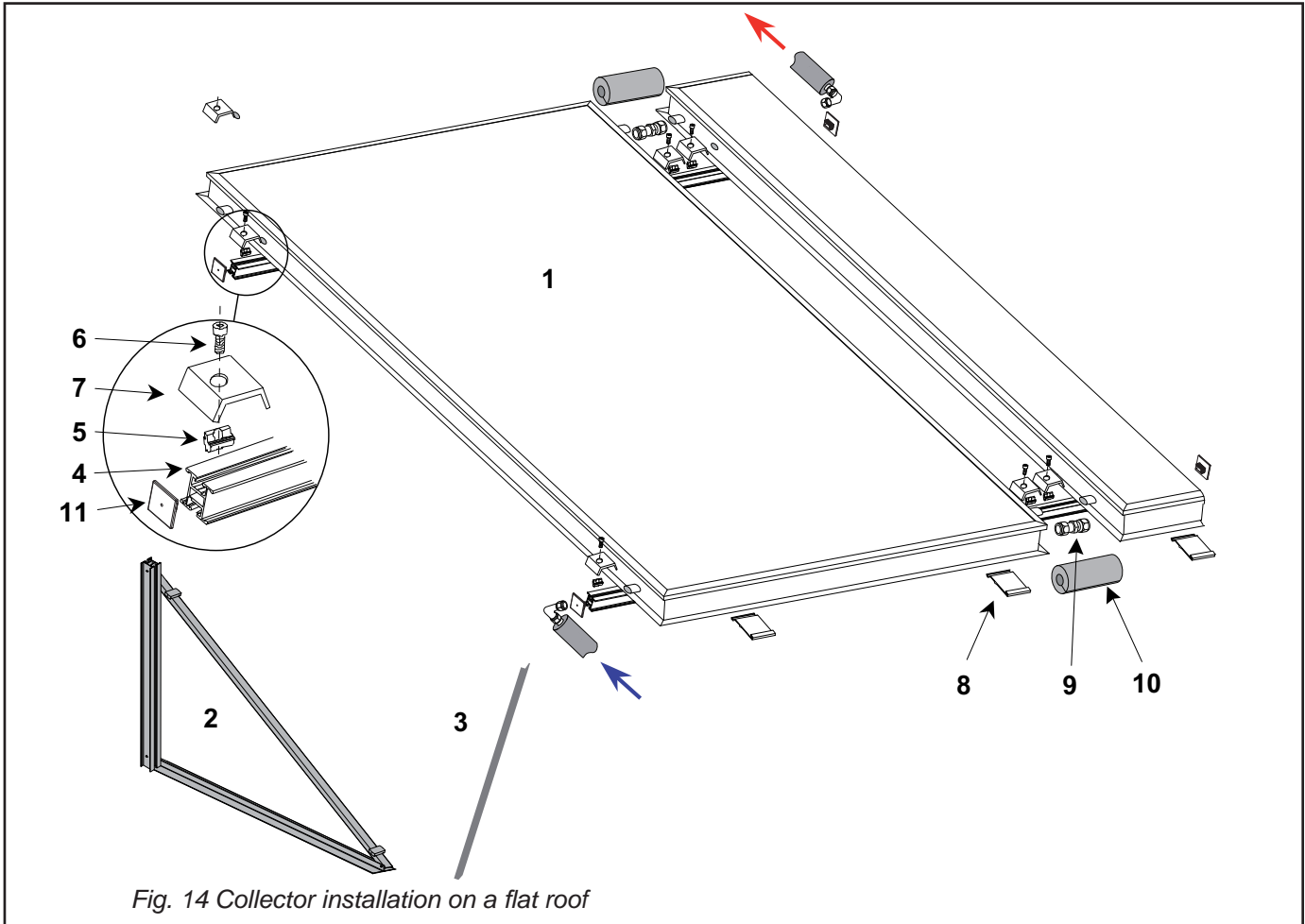

Fig. 14 Collector installation on a flat roof

4.1 - Overview

Pos.	Item	Number of collectors (number of supports needed)				Code
1	Flat plate collector					10646
2	Triangular support, for 45°, 25° and 15° inclination	Number of collectors (number of supports needed)				6859, 10975, 11979
		1 (2)	2 (3)	3 (4)	4 (5)	
3	Strut incl. bolts for triangular support					9563
	Interconnection pipes					
Mount and interconnection kits						
		Number of collectors (kit code)				Item code
		1 (12184)	2 (12185)	3 (12186)	4 (12187)	
4	Aluminum base rail, 2 pieces	1.32 m	2.6 m	3.9 m	5.18 m	6949
5	M8 nut for the base rail	4 pcs	8 pcs	12 pcs	16 pcs	6925
6	M8x20 bolt (allen head)	4 pcs	8 pcs	12 pcs	16 pcs	12136
7	Retaining side bracket for KPS11+	4 pcs	8 pcs	12 pcs	16 pcs	12141
8	Retaining bracket for collector bottom	2 pcs	4 pcs	6 pcs	8 pcs	11690
9	Compression nut and ring for collector interconnection	-	2 pcs	4 pcs	6 pcs	7629
10	Insulation 35 mm diam., 19 mm thick	0.5 m	0.75 m	1 m	1.5 m	7188
11	Rail end plug	4 pcs	4 pcs	4 pcs	4 pcs	11773
	Insulation tape	0.8 m	1 m	1.5 m	2 m	7227
Expansion mount and interconnection kits for 1 KPS11+ solar collector						Code
Expansion mount and interconnection kit for 1 KPS11+ solar collector						12188

4.2 - Flat roof support mounting

A flat roof support consist of two base rails, triangular supports and one strut.

The number of triangular supports depends on the number of collectors. One strut is sufficient to support up to 4 collectors.

Installation:

- Lay two rails in parallel on the mounting surface, their pitch shall be 1660 mm.
- The diagonals between the rails shall be of the same length: $D1 = D2$ (Fig. 15)
- Insert the M8 bolt with a special head (Fig. 17) into the rail grooves.

- Assemble the triangular supports that come partially screwed together (Fig. 16). Fix the loose support ends with a bolt (Fig. 16) and tighten all connections.
- Locate the positions to fix triangular supports. The distance of the first triangular support from the end of the rail shall be about 350 mm.
- Fix the L-support of the triangle to the base rail using screws, serrated lock washers and nuts for rails (Fig. 17) and tighten the connections.
- Install the next triangular support in the same way. Its distance is the same as that of the roof anchors in Fig. 2.

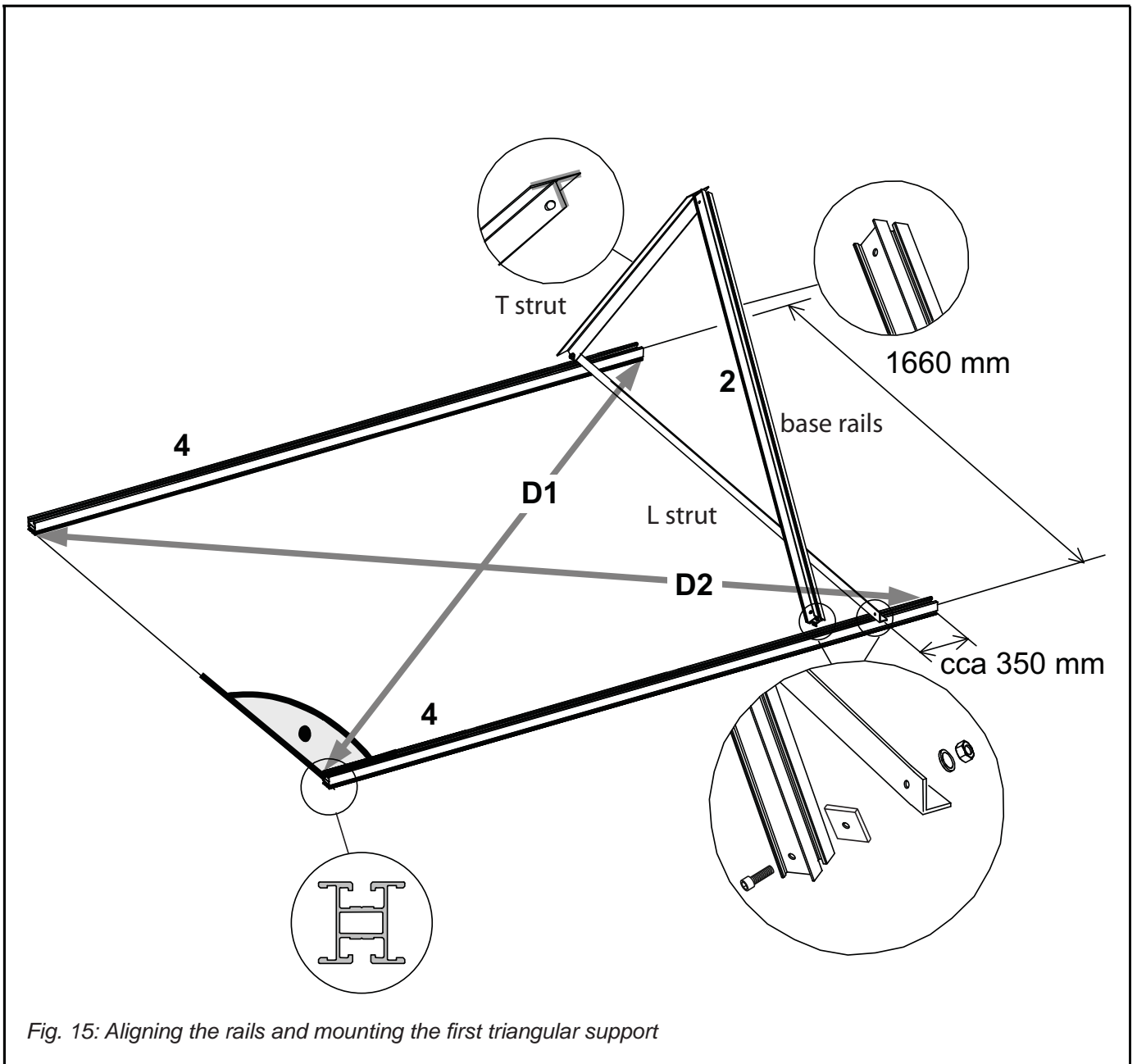

Fig. 15: Aligning the rails and mounting the first triangular support

- Install the strut between the two triangular supports (Fig. 18). Following Fig. 18, insert special M8 nuts into the triangle support rail. Then lay the strut onto the rails and fix it with M8x12 bolts with washers (Fig. 18).
- Continue assembling the remaining triangular supports with a pitch as shown in Fig. 2. Adjust this distance so that the pitch of the triangular supports is similar to that of roof anchors in Fig. 2.



After fixing the strut and other supports, kip the entire structure into the position intended for collector installation. (The strut is upright, T rail of each triangular support lies on the ground.)

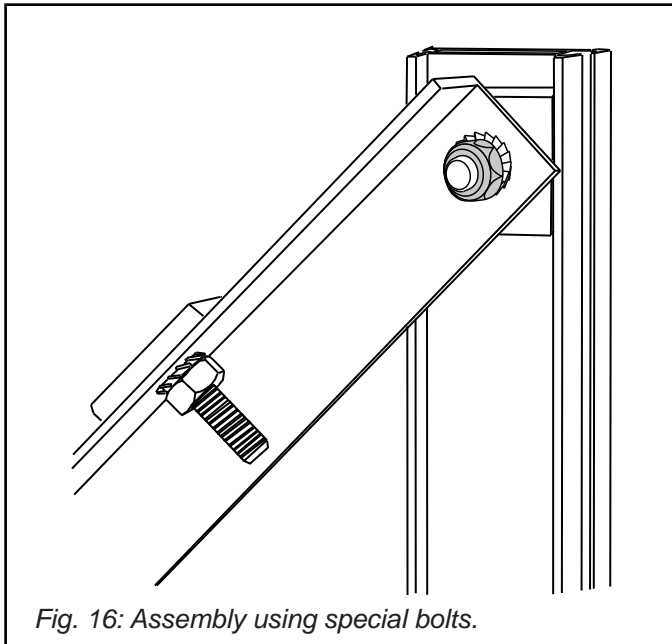

Fig. 16: Assembly using special bolts.

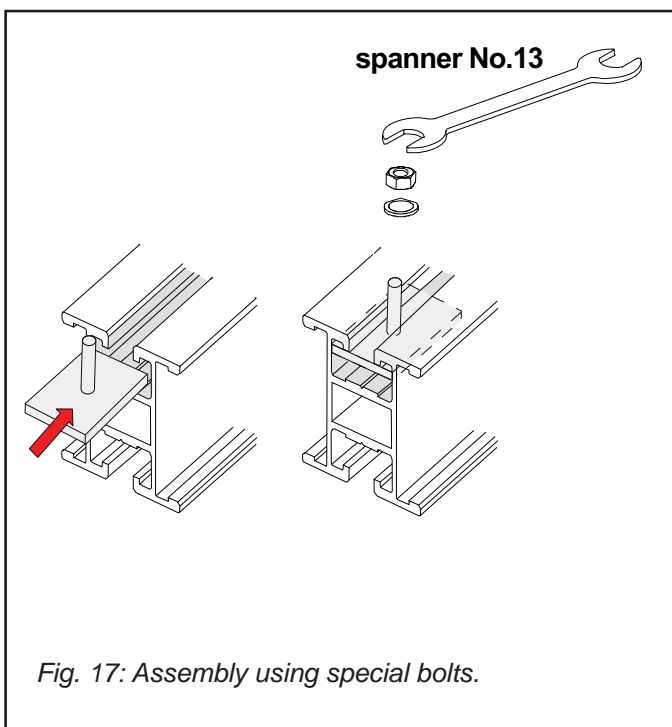

Fig. 17: Assembly using special bolts.

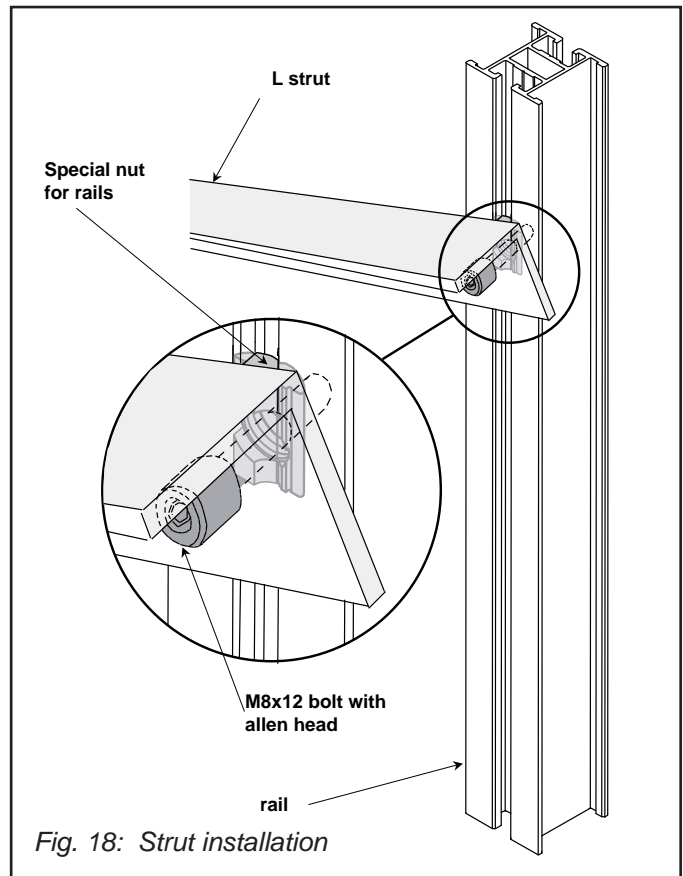

Fig. 18: Strut installation

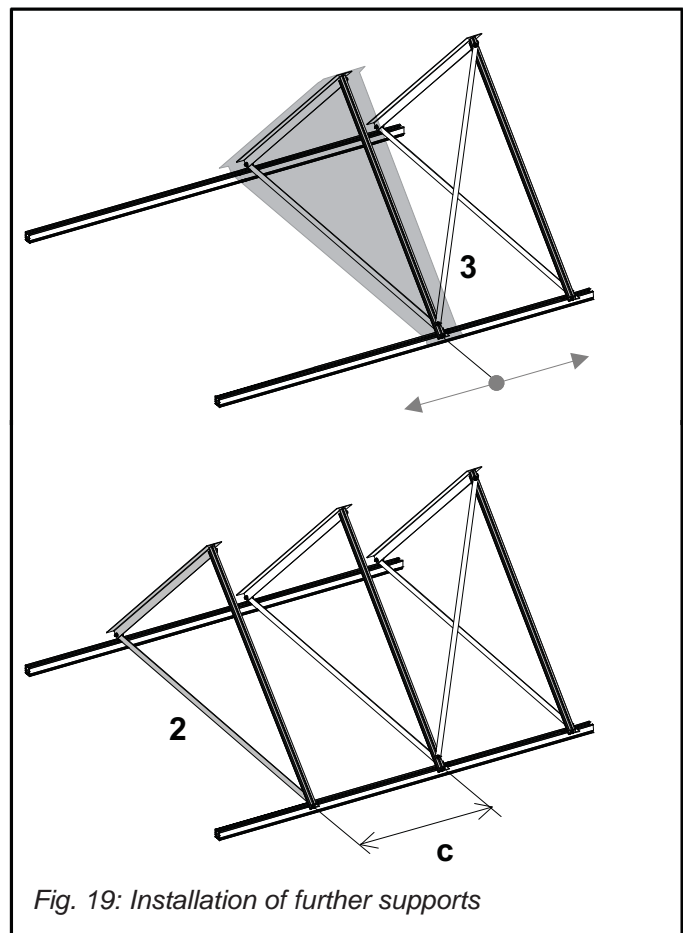

Fig. 19: Installation of further supports

Secure the support structure either by screwing it into the roof, or applying a burden.



In no event the permissible roof load shall be exceeded. Consulting a statics expert in advance is necessary. A damaged roof must be re-insulated by a specialist.

Fix the collectors to the rails in the same manner as if installing on an inclined roof (see point 2.4).

Minimum distance between collector arrays see Fig. 21.

Flat roof mount	up to 8m high roof
1 collector	290 kg
2 collectors	580 kg
3 collectors	870 kg
4 collectors </td <td>1160 kg</td>	1160 kg

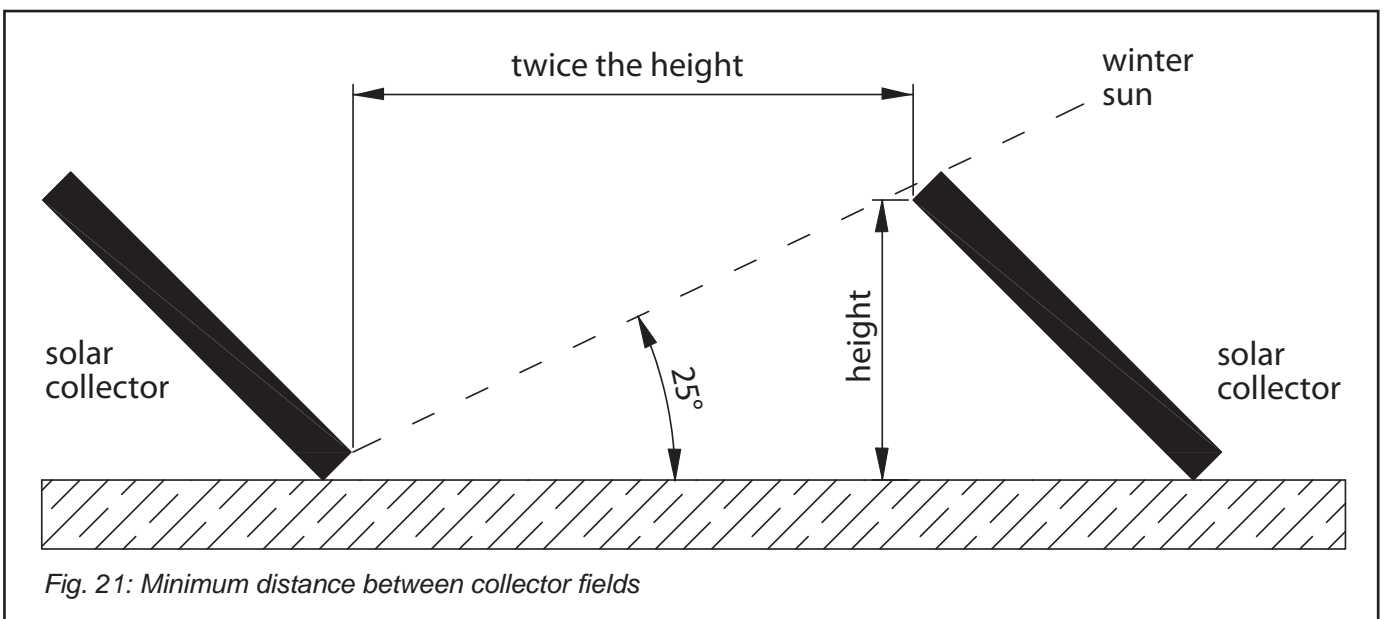
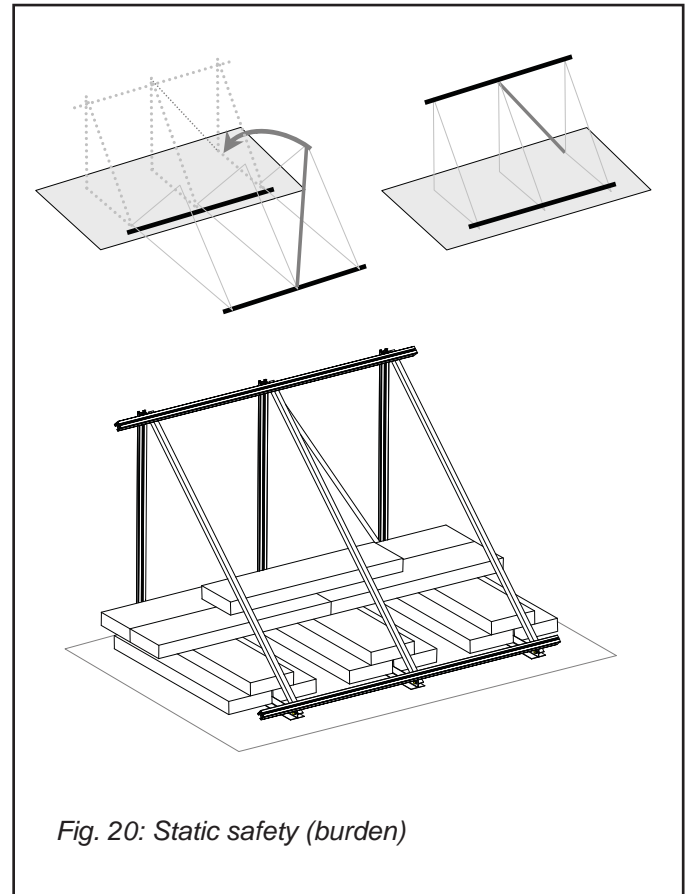

5. HYDRAULIC CONNECTION

5.1 - Collector connecting

For collector mounting follow the instructions in chapter 5.2. Fasten the first collector and lay the following one next to the first one, maintaining a sufficient gap. Then put the threaded fittings on both the upper and lower outlets and push the collector to the already mounted one until stop. Hold the fitting with a spanner (Fig. 23) to prevent turning, and tighten the nuts. Continue in the same way with further collectors.



Put the insulation on the threaded fittings only after a successful leak test.

5.2 - Collector interconnecting

Hydraulic interconnection of collectors shall be done according to Fig. 22a. Maximum of 4 collectors may be connected with threaded fittings in a row. If there are more than 4 collectors in a row, a compensator shall be installed in the middle of the array. With a compensator, max. of 8 collectors in a row may be installed. The connecting pipes shall be lead the shortest way. The recom-

mended pipe diameters and flow rates through collector arrays are shown in Tab. 1.

Collectors may be also connected as shown in Fig. 22b. This kind of connection is permitted when only **max. 2 collectors** are used and **the max. flow rate is 1l/min/collector**. Then the cold liquid inlet is at one side bottom and the hot liquid outlet is at the same side top. Both the other ends shall be plugged.

A brass elbow shall be installed at the inlet to the collector array with a transition to the interconnection piping. At the outlet from the collector array, a brass adapter shall be installed that will enable connection to the piping. The brass elbow and adapter are involved in Regulus connection kit, code 7710.

All solar components must be carefully and safely sealed and must be made of material resistant to glycol and temperatures up to 160 °C. For connection piping we recommend using KOMBIFLEX stainless-steel flexible pipes, or copper pipes joined by soldering.

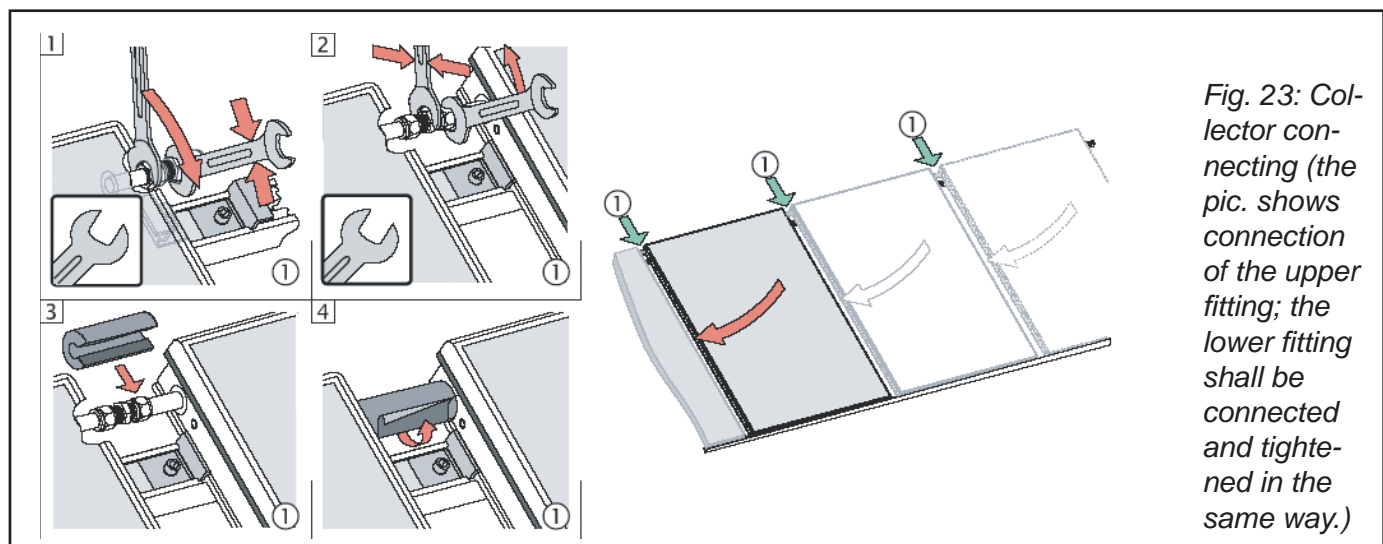
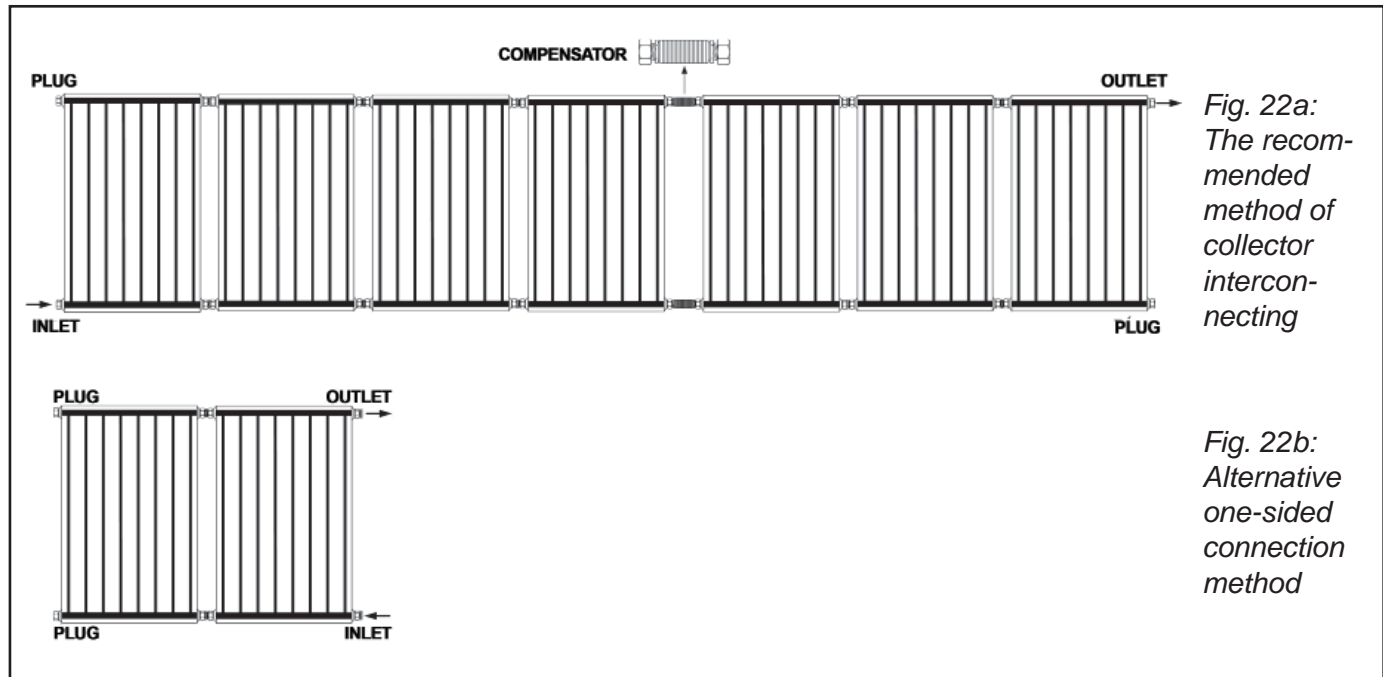

Number of collectors	Connection type array x collector	Max. recomm. flow rate	Connecting pipe	
			Copper	Kombiflex
1	1 x 1	2l/min	Cu 15 x 1	DN 12
2	1 x 2 series	4l/min	Cu 15 x 1	DN 16
3	1 x 3 series	6l/min	Cu 18 x 1	DN 16
4	1 x 4 series	8l/min	Cu 18 x 1	DN 20
6	2 x 3 parallel	12l/min	Cu 22 x 1	DN 25
8	2 x 4 parallel	16l/min	Cu 28 x 1.5	DN 25
9	3 x 3 parallel	18l/min	Cu 28 x 1.5	DN 25
12	3 x 4 parallel	24l/min	Cu 28 x 1.5	-
Max. 30 m of the inlet and outlet piping together.				

Tab. 1: Recommended pipe diameters

In no event plastic tubes can be used for inlet/outlet piping as they do not meet the operation requirements for solar systems.

Pipes for collectors can be lead through disused chimneys, ventilation shafts or grooves in a wall. In order to prevent high thermal losses through convection, open shafts shall be properly sealed. Also thermal dilatation shall be remembered and pipes fitted with compensators or other compensation elements.



Piping shall be connected to the house earthing.

Pipes of the solar system must be fitted with thermal insulation e.g. of AEROFLEX type, so that thermal dissipation from the pipes does not deteriorate a total efficiency of the solar system. The thermal insulation must be resistant to temperatures up to 160 °C, for outdoor piping also a UV protection is essential as well as non-deliquescence of the material. For indoor piping, the thermal insulation should be at least 13 mm thick, for outdoor piping at least 19 mm.

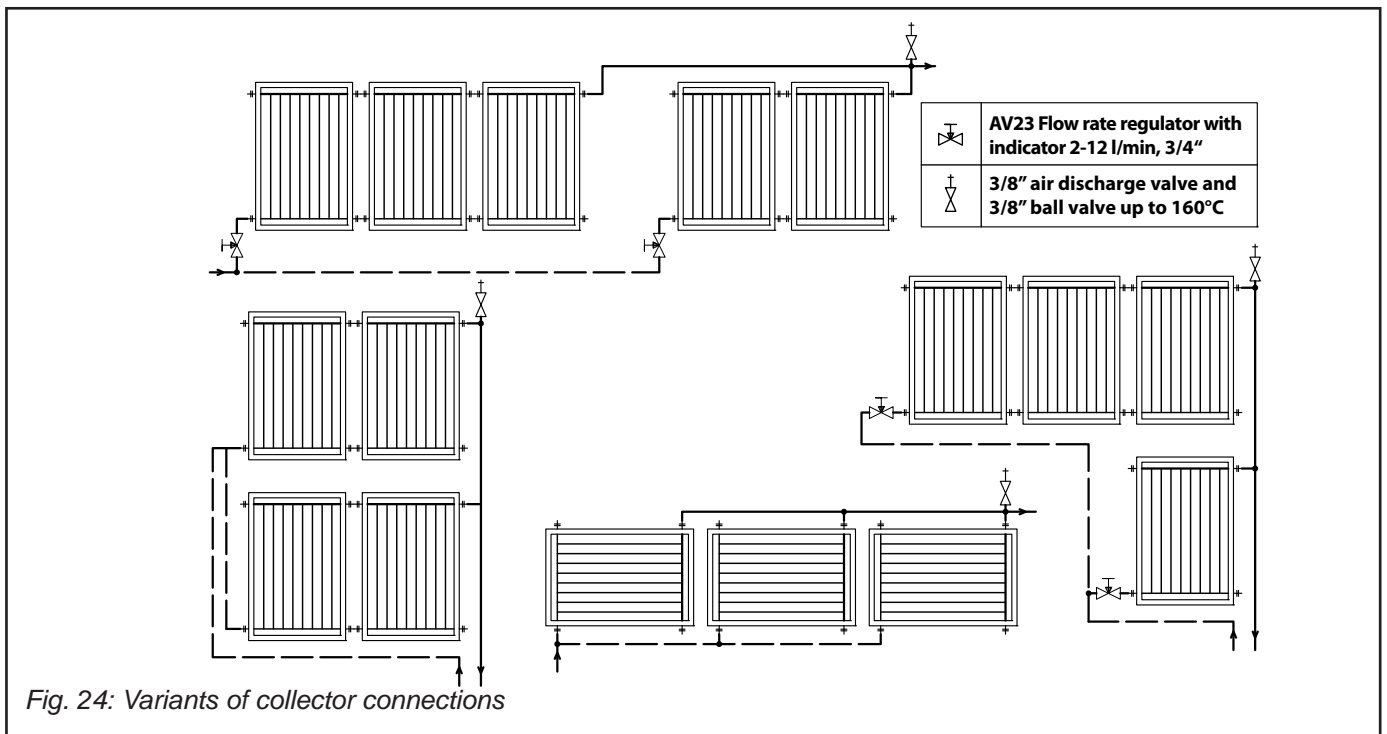

Fig. 24: Variants of collector connections

6. TEMPERATURE SENSOR POSITIONING

Place the thermal probe into the pocket of the T- or X-piece at the outlet from the last collector, see pic. 25. A twisted wire 2x1 mm², non-shielded should be used, separated from power cables.

Its maximum length is 100 m. Minimize the number of electrical boxes a terminal blocks.

connection length: up to 25 m cross section: 0.25 mm²

connection length: up to 50 m cross section: 0.5 mm²

connection length: up to 100 m cross section: 1.0 mm²

- the thermal and mechanical resistance of the wire used shall correspond to the environs the wire passes through.

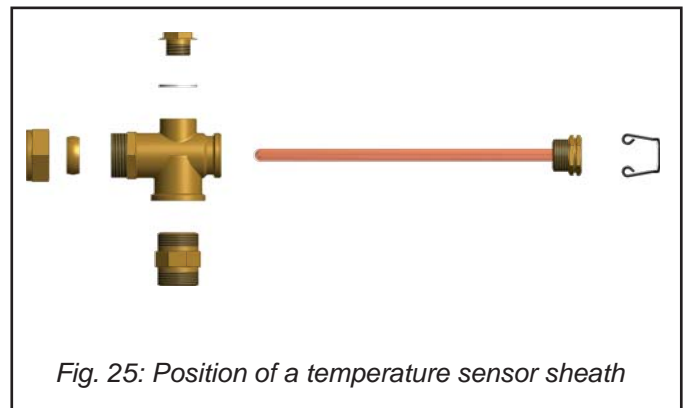

Fig. 25: Position of a temperature sensor sheath

7. SOLAR PUMP STATION

The pump station shall be installed in accordance with the respective manual.

Regulus pump stations contain the principal components shown in Fig. 26:

Safety valves are always included in pump stations. If no pump station is used in the installation, the solar system shall be equipped with a 6 bar safety valve, resistant to 160 °C.

No shut-off valve shall be installed between a safety valve and collectors.

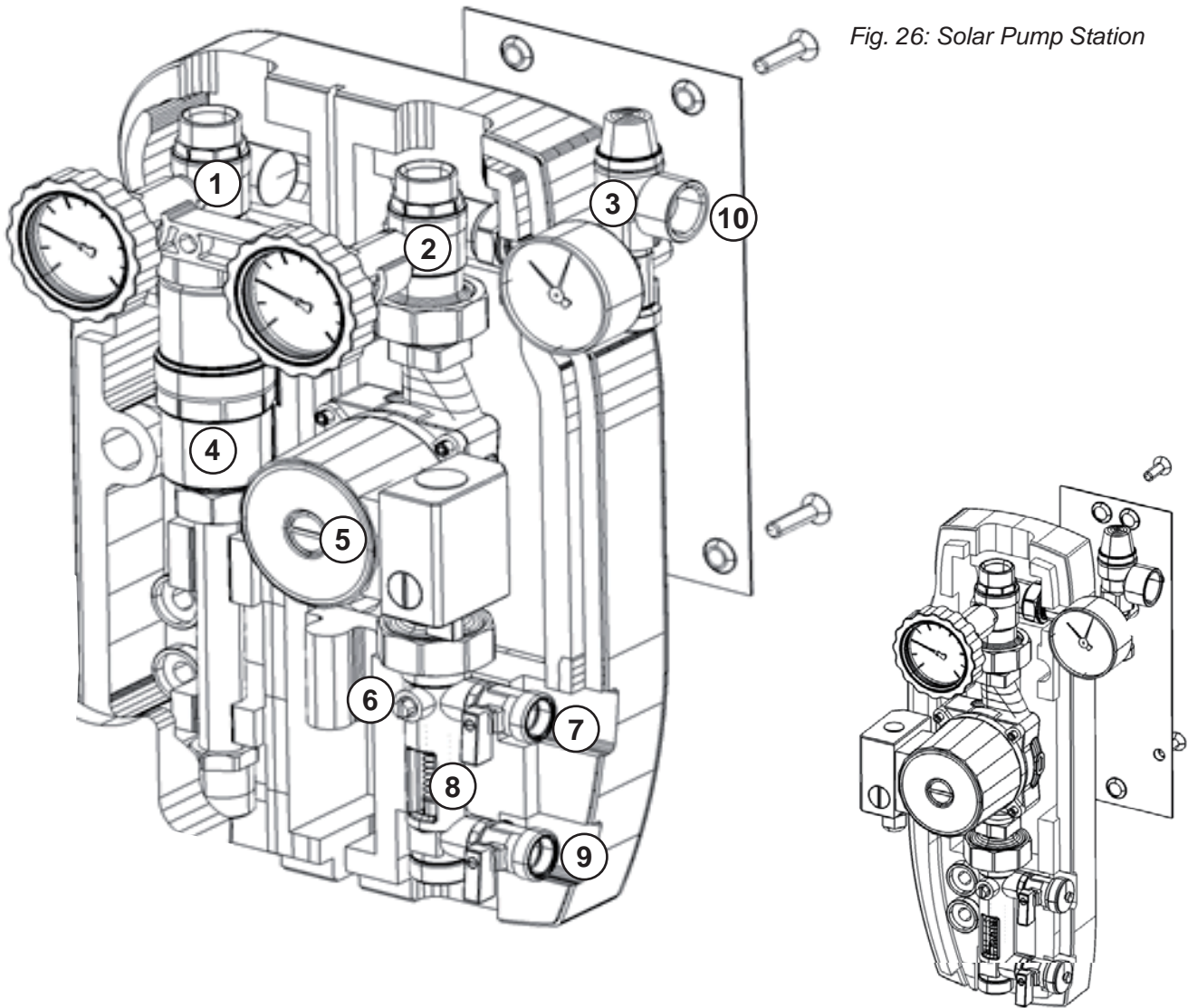

Fig. 26: Solar Pump Station

- 1 - Ball valve on flow line (red frame thermometer, 0-120 °C dial), with check valve
- 2 - Ball valve on return line (blue frame thermometer, 0-120 °C dial), with check valve
- 3 - Safety unit protects the installation from overpressure. It involves a 6 bar safety valve, manometer and G ¼" connection to expansion tank.

- 4 - Air eliminator
- 5 - 3-speed circulation pump, manual control
- 6 - Flow control screw
- 7 - Filling valve
- 8 - Flowmeter
- 9 - Drain valve
- 10 - Safety valve spillway connection

8. EXPANSION VESSEL SIZING AND WORKING PRESSURE CALCULATION

(Tab. 2 is valid for height up to 20 m only, otherwise the size shall be calculated.)

8.1 - Expansion vessel sizing

A solar expansion vessel shall be sized for a temperature difference between the min. winter temperature and the max. summer temperature. The working range of expansion vessels is from -10 °C to +130 °C. Further it shall be able to contain fluid volume of all collectors in case of stagnation (max. collector temperature at no flow and high sunshine intensity). In solar systems with forced circulation such pressure expansion vessels shall be only used that are fitted with a propylene-glycol resistant membrane and whose min. working pressure is 6 bar. Installation shall be done in a position with the diaphragm flooded. In case the heat carrier starts boiling, the diaphragm mustn't get in touch with steam!

For the recommended size of an expansion vessel see **Table 2**.

Number of collectors	Expansion vessel size	Max. piping length
3	18	Max. 30 m of the inlet and outlet piping together
4	25	
5	40	
6	60	
8	60	
9	80	
10	80	
12	100	

Tab. 2: Expansion vessel recommended size. Max. 30 m of the inlet and outlet piping together.

8.2 - Calculation of a system working pressure

The pressure in the solar system is calculated using the relation

$$p = 1.3 + (0.1 h)$$

p...pressure in a solar system [bar]

h...height from a pressure gauge to the middle of a collector field [m]

Adjust the pressure by discharging solar liquid after the pressure test is done



Fig. 27: Expansion vessel

8.3 - Calculation of expansion vessel preset pressure

Before filling the system, adjust the initial overpressure in the expansion vessel to a value by 0.5 bar below the calculated system pressure.

$$p_{exp} = p - 0.5 \text{ [bar]}$$

In order to set the pressure, use a current car-tyre pressure gauge of a suitable pressure range.

The expansion vessel has a current tyre valve under its lid.

8.4 - Examples of calculating working pressure and expansion vessel pressure

8.4.1 - An example of calculating system working pressure

The height from a pressure gauge to the middle of a collector:

$$h = 10 \text{ m}$$

Pressure in the solar system (the solar system is to be pressurized to this value):

$$p = 1.3 + (0.1 h) = 1.3 + (0.1 \cdot 10) = 2.3 \text{ bar}$$

8.4.2 - An example of calculating expansion vessel pressure

Before filling the system, the preset pressure in the expansion vessel shall be adjusted to the value of:

$$p_{exp} = p - 0.5 = 2.3 - 0.5 = 1.8 \text{ bar}$$

9. INSTALLATION OF AIR RELEASE VALVES

Install the air vent at the highest point of the system. Should there be more places with a risk of air pockets, air vents should be installed also there.

It is recommended to amend the air vent with a local pipe widening that calms down the stream and helps in good separating bubbles from the fluid (see pic. 29).

A ball valve shall be always installed under the automatic air vent valve, so that the automatic air vent can be closed after the system commissioning. Solar liquid leaks can be avoided in case of system stagnation.

For an efficient removal of bubbles from the system it is advisable to fit the pump station with an air eliminator (see Fig. 28).



Fig. 28: Air eliminator



Fig. 29: Horizontal air eliminator and an automatic air vent

10. SYSTEM FILLING, FLUSHING, LEAK TEST AND AIR BLEEDING

The below listed procedures are valid when a Regulus pump station is used.

10.1 Filling

- in order to fill the system, use a filling device with a reservoir for solar liquid and a filling pump (see Fig. 30)
- attach the filling hose to the feed valve and open the valve completely
- please use antifreeze solar fluid Regulus - Solarten Super to fill the system
- attach the return hose to the bleed valve and open the valve completely
- close the integrated ball valve in the flowmeter (the groove in the flowmeter's adjusting screw must be horizontal).
- open the check valve (valves - two for a twin-pipe solar pump station) above the pump by turning the ball valve by 45° (intermediate position between open and closed)
- pour sufficient quantity of solar fluid into the reservoir of the filling device, turn on the filling pump and fill the solar system.

10.2 Flushing

- flush the solar system for at least 15 minutes using the filling device. In order to bleed air and possible impurities from the system perfectly, open shortly the integrated ball valve of the flowmeter from time to time (the groove vertically).

10.3 Air bleeding

- with the filling pump running, close the bleed valve and increase the pressure up to about 5 bar
- close the feed valve and turn off the filling pump, open the regulation screw on the flowmeter (groove horizontally), do not disconnect the filling pump hoses!
- set the circulation pump(s) to the highest speed and repeat switching on and off to air-bleed the system (an air-free pump works almost noiselessly)
- watch the system pressure and when it starts falling, increase it by turning on the filling pump and opening the feed valve to 5 bar
- repeat air bleeding so long until the float in the flowmeter's regulation valve takes a steady position during pump operation and bubbles stop appearing in the flowmeter. After that, let the circulation pump run for at least 5 minutes.



Fig. 30: Filling a solar system

- in case an automatic air vent/s is/are used anywhere in the solar system, close this valve after air bleeding

10.4 Leak test

- examine the whole system at 5 bar pressure (all connections, solar collectors, valves etc.), no visible leaks are allowed. Leave the system under pressure for at least 2 hours, then examine the system once again
- consider the test result successful if no leaks appear and/or no noticeable pressure drop appears in the system
- set the working pressure by point 8.2 Calculation of system working pressure
- set the pump to a suitable speed and set the flow by the flowmeter and data in Tab. 1
- disconnect the hoses of the filling device and screw caps on the feed and bleed valves
- **open entirely** the ball valve(s) above the pump
- after several days of operation, air-bleed the system again.

Do not flush the system with water. Since it is impossible to empty it completely, a risk of frost damage appears.

11. COMMISSIONING

- Adjust the solar controller.
- Select an appropriate hydraulic variant in the controller menu. Check the controller settings and adjust parameters.



During solar controller setup, activate the respective safety functions (collector protection, night recooling).

- uncover the collectors
- place a sufficiently sized vessel (to hold the entire solar fluid volume) under the safety valve spillway
- check if the circulation pump switches when the preset temperature difference between solar collectors and secondary circuit is reached

12. OPERATION, CHECKS AND MAINTENANCE

The solar system offers unmanned and almost maintenance-free operation. Despite that, it is important to check the right functioning of the system within the first days of operation. First of all the temperature, system pressure and pump operation shall be checked. Once a year, preferably during a sunny day, it is necessary to check the working order and tight fixing of the collectors, verify the system tightness and pressure (incl. pressure

in the expansion vessel) and the pump operation. At least once in every 2 years the heat carrying fluid shall be checked for its antifrost properties. The system shall be always replenished with the same fluid as the original filling was.



The system must not be replenished with water. Always use solar liquid supplied by Regulus.

13. SERVICING AND WARRANTY

Service or maintenance of the appliance may be done exclusively by an authorized person, holder of a valid authorization issued by Regulus, spol. s r.o.

Regulus offers warranty for this product under the conditions specified in the Warranty Certificate. The Warranty Certificate is an integral part of the documents supplied with the product.

In case you wish to claim warranty, please contact your system supplier - installer.

14. DATA SHEET FOR KPS11+ SOLAR COLLECTOR

Dimensions and Weight	
height × width × thickness	2030 × 1230 × 92 mm
construction width	1280 mm
total area	2.49 m ²
aperture area	2.31 m ²
absorber area	2.31 m ²
empty weight	50 kg
Glass	
material	tempered prismatic glass
thickness	4 mm
Absorber	
material	aluminum, 0.5 mm thick
surface finish	TiNOx
design	harp type, laser welded
connection pipes material	copper
connection pipes dimension	4 × Ø 22 mm × 0.7 mm
absorber tube material	copper
absorber tube dimension	11 × Ø 8 mm × 0.5 mm
max. working pressure	10 bar
max. working temperature	120 °C
stagnation temperature	196 °C
heat carrier	solution of monopropylene glycol in water, 1:1, 1.64 l
recommended flow rate	60 – 120 l/h
Thermal Insulation	
material	mineral wool
insulation thickness	40 mm
Frame	
material	aluminum alloy
color	RSL 7039
back plate	zinc-plated sheet iron , 0.5 mm thick
Momentary efficiency per aperture / absorber area	
η_{0a}	0.79 / 0.79
a_{1a}	3.48 / 3.48 W/m ² K
a_{2a}	0.0056 / 0.0056 W/m ² K

tested by EN 12975:2006; 01/2015

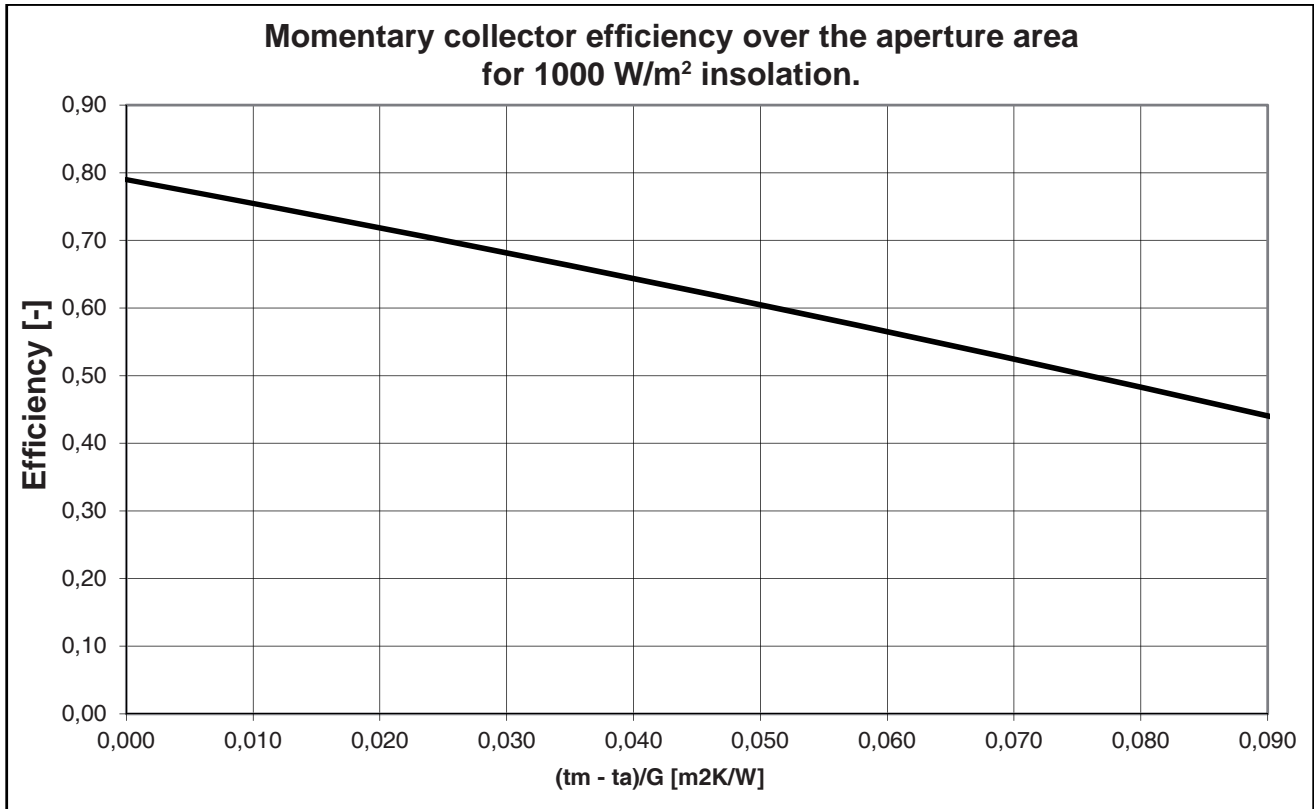

KPS11+ Collector power output in zero point for G=1000 W/m² is 1825 W.

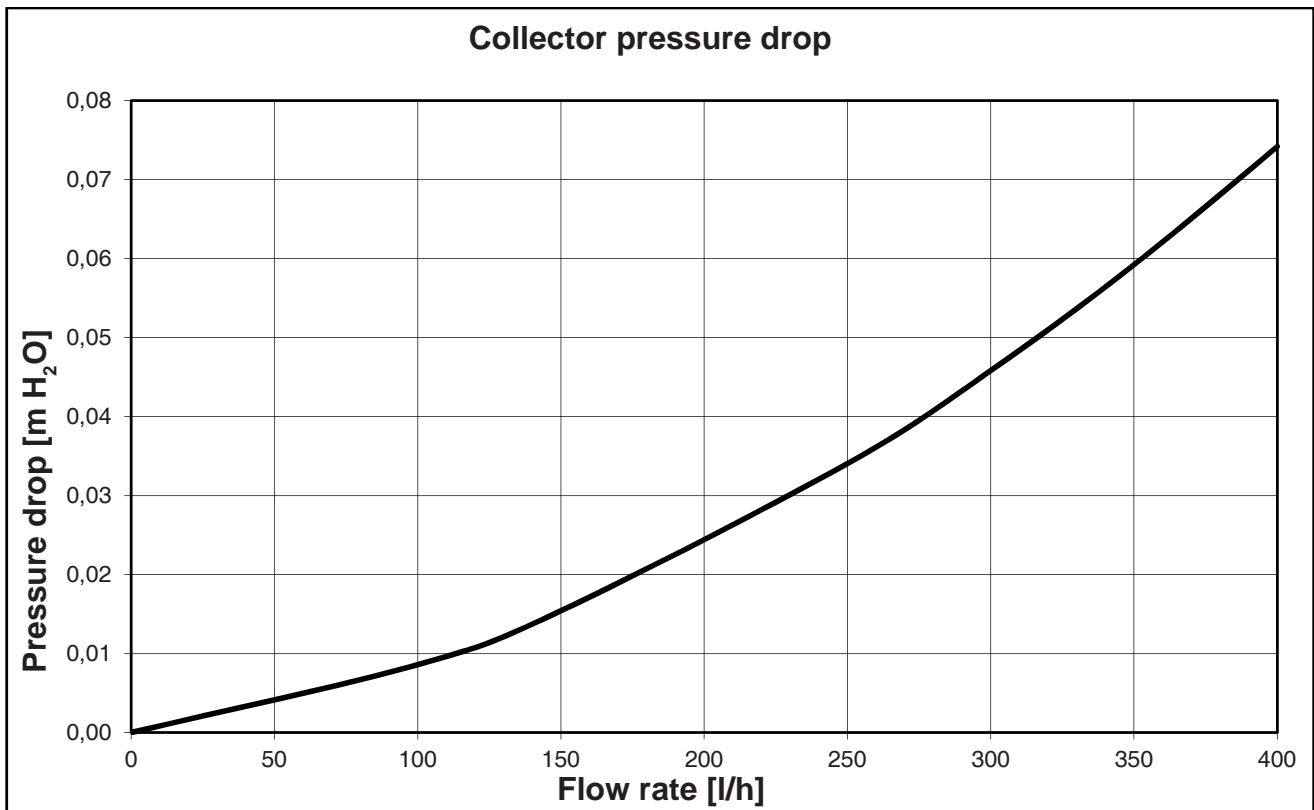

15. CONNECTION DIMENSIONS

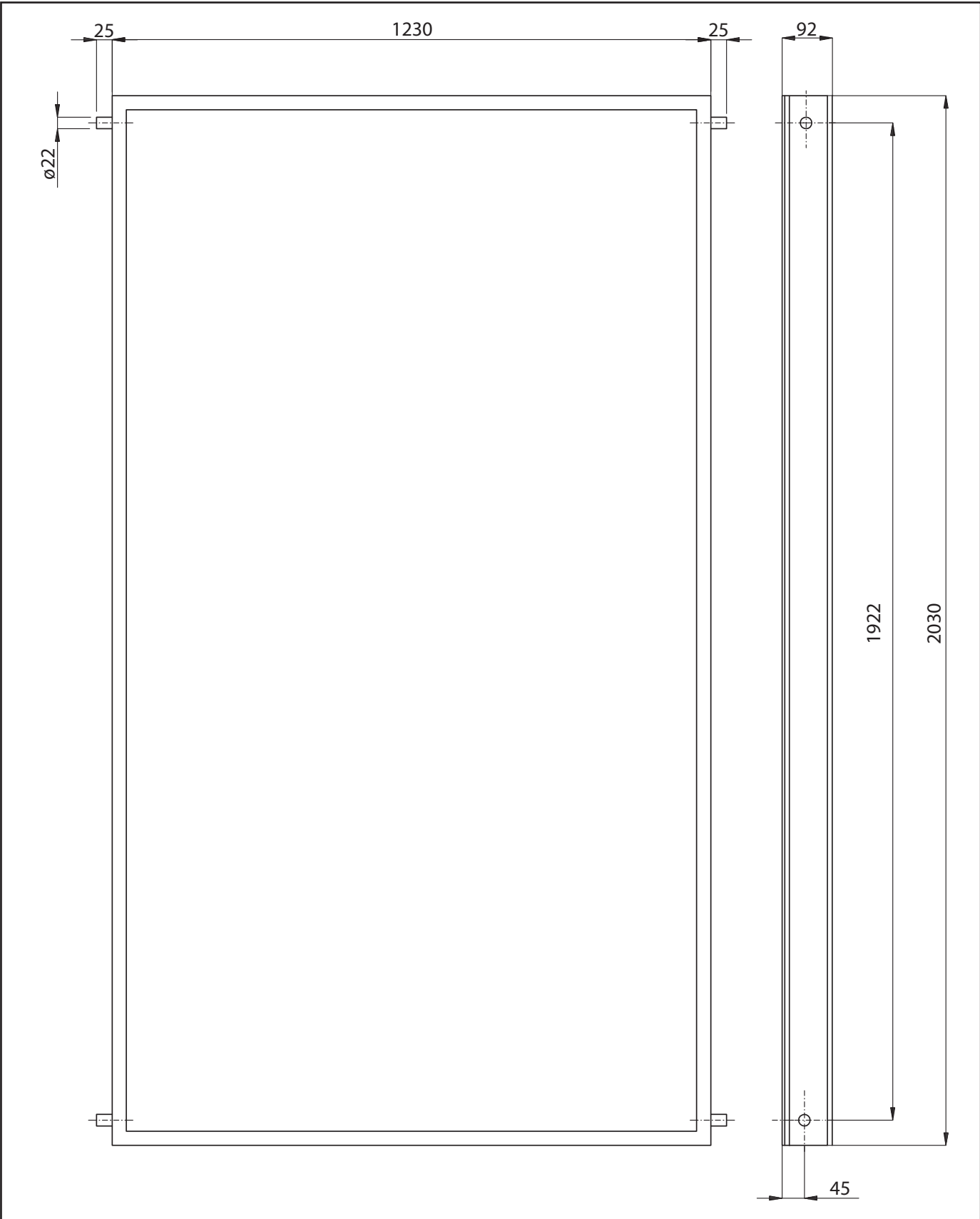

16. DESCRIPTION OF PROCEDURES FOR ANNUAL PREVENTION CHECKS



Warning: Prevention examination and eventual intervention may be carried out by a qualified person only. Any work on electric wiring may be done by an authorized electrician. Maximum care shall be taken during checks. In case the

procedure requires a person to get on a roof, a fall arrest is necessary.

Check procedures	Year 1	Year 2	Year 3	Year 4	Year 5	Year 6
Check the pressure in expansion vessel, replenish if necessary	<input type="checkbox"/>	<input type="checkbox"/>	<input type="checkbox"/>	<input type="checkbox"/>	<input type="checkbox"/>	<input type="checkbox"/>
Check system visually for leaks	<input type="checkbox"/>	<input type="checkbox"/>	<input type="checkbox"/>	<input type="checkbox"/>	<input type="checkbox"/>	<input type="checkbox"/>
Check the collector glazing cleanliness, wash if necessary	<input type="checkbox"/>	<input type="checkbox"/>	<input type="checkbox"/>	<input type="checkbox"/>	<input type="checkbox"/>	<input type="checkbox"/>
Check ambient trees for possible shading	<input type="checkbox"/>	<input type="checkbox"/>	<input type="checkbox"/>	<input type="checkbox"/>	<input type="checkbox"/>	<input type="checkbox"/>
Check pipe insulation	<input type="checkbox"/>	<input type="checkbox"/>	<input type="checkbox"/>	<input type="checkbox"/>	<input type="checkbox"/>	<input type="checkbox"/>
Check the proper flow rate	<input type="checkbox"/>	<input type="checkbox"/>	<input type="checkbox"/>	<input type="checkbox"/>	<input type="checkbox"/>	<input type="checkbox"/>
Check temperature probes	<input type="checkbox"/>	<input type="checkbox"/>	<input type="checkbox"/>	<input type="checkbox"/>	<input type="checkbox"/>	<input type="checkbox"/>
Check the quality of antifreeze liquid (with a refractometer)*	<input type="checkbox"/>	<input type="checkbox"/>	<input type="checkbox"/>	<input type="checkbox"/>	<input type="checkbox"/>	<input type="checkbox"/>
Check the heat carrier pressure, replenish if necessary	<input type="checkbox"/>	<input type="checkbox"/>	<input type="checkbox"/>	<input type="checkbox"/>	<input type="checkbox"/>	<input type="checkbox"/>
Check the controller settings	<input type="checkbox"/>	<input type="checkbox"/>	<input type="checkbox"/>	<input type="checkbox"/>	<input type="checkbox"/>	<input type="checkbox"/>
Check for possible error messages in the controller and their reason	<input type="checkbox"/>	<input type="checkbox"/>	<input type="checkbox"/>	<input type="checkbox"/>	<input type="checkbox"/>	<input type="checkbox"/>
Check wiring	<input type="checkbox"/>	<input type="checkbox"/>	<input type="checkbox"/>	<input type="checkbox"/>	<input type="checkbox"/>	<input type="checkbox"/>
Check backup heating function (el. heating rod, gas-fired boiler)	<input type="checkbox"/>	<input type="checkbox"/>	<input type="checkbox"/>	<input type="checkbox"/>	<input type="checkbox"/>	<input type="checkbox"/>
Check the magnesium anode rod in the tank, replace if necessary (see Instruction Manual)	<input type="checkbox"/>	<input type="checkbox"/>	<input type="checkbox"/>	<input type="checkbox"/>	<input type="checkbox"/>	<input type="checkbox"/>
Check the function of all system valves and fittings	<input type="checkbox"/>	<input type="checkbox"/>	<input type="checkbox"/>	<input type="checkbox"/>	<input type="checkbox"/>	<input type="checkbox"/>
Check the collector fixing	<input type="checkbox"/>	<input type="checkbox"/>	<input type="checkbox"/>	<input type="checkbox"/>	<input type="checkbox"/>	<input type="checkbox"/>
If needed, check the pressure in the heating system expansion vessel	<input type="checkbox"/>	<input type="checkbox"/>	<input type="checkbox"/>	<input type="checkbox"/>	<input type="checkbox"/>	<input type="checkbox"/>
If needed, clean the filter and de-aerate the heating system	<input type="checkbox"/>	<input type="checkbox"/>	<input type="checkbox"/>	<input type="checkbox"/>	<input type="checkbox"/>	<input type="checkbox"/>
Preventive training in system maintenance and controller setting for the operating staff	<input type="checkbox"/>	<input type="checkbox"/>	<input type="checkbox"/>	<input type="checkbox"/>	<input type="checkbox"/>	<input type="checkbox"/>

**If the test result shows the necessity, fill new heat carrier.*

17. SERVICE ACTION FORM

This Service Sheet is intended to register service intervention done. Entries may be recorded by an authorized servicing company.

This Service Action has been carried out by an authorized servicing company

Date of Service Action:

Name of the servicing company:

Address of the servicing company:

Name of the servicing person:

Contact phone:

Description of the intervention:

Signature of the person who has carried out the service action:

This Service Action has been carried out by an authorized servicing company

Date of Service Action:

Name of the servicing company:

Address of the servicing company:

Name of the servicing person:

Contact phone:

Description of the intervention:

Signature of the person who has carried out the service action:

This Service Action has been carried out by an authorized servicing company

Date of Service Action:

Name of the servicing company:

Address of the servicing company:

Name of the servicing person:

Contact phone:

Description of the intervention:

Signature of the person who has carried out the service action:

REGULUS spol. s r.o.
Do Koutů 1897/3
143 00 Praha 4
<http://www.regulus.eu>
E-mail: sales@regulus.cz

Your service: