



www.regulus.eu



HSK 250, 650 PB

Installation and Operation Manual
THERMAL STORE
with stainless-steel DHW heat exchanger
HSK 250, 650 PB

EN

HSK 250, 650 PB

CONTENTS

1 Description	3
1.1 Models	3
1.2 Tank protection	3
1.3 Thermal insulation	3
1.4 Packaging	3
2 General Information	3
3 Technical Data and Dimensions of HSK PB Thermal Stores	4
4 Operation	5
5 Connection of HSK PB to a Heating System	6
6 Installation and Commissioning	7
6.1 Connection to heat sources	7
6.2 Connection to water mains	7
6.3 Commissioning	7
7 Installing Insulation on the Tank	7
8 Maintenance	8
9 Disposal	8
10 Warranty	8

1 - Description

Combination thermal stores of HSK PB series with an integrated stainless-steel heat exchanger and a tight separating metal plate is intended for storing heat and heating of domestic hot water. Thanks to the modified construction and the tight separating plate, it is sufficient to use only one zone valve for switching between heating the upper and lower part of the tank. The tank is suitable for installations with heat pumps and a RegulusBOX indoor unit.

1.1 - Models

Two models of 260 and 625 l total volume with stainless-steel DHW heat exchanger.

1.2 - Tank protection

The inner side of the thermal store has no surface finish, the outer surface is painted in gray. The DHW heat exchanger is made of stainless steel.

1.3 - Thermal insulation

Thermal insulation is available as a separate item. For easier handling, the insulation shall not be fitted on the tank until it reaches its definite place of installation. The insulation is made of fleece, 100 mm thick, with a hard polystyrene surface.

1.4 - Packaging

Thermal stores are delivered standing, each screwed to its pallet, packed in bubble wrap

It is forbidden to transport and/or store the thermal stores in a horizontal position.

2 - General Information

This Manual is an integral and important part of the product and must be handed over to the User. Read carefully the instructions in this Manual as they contain important information concerning safety, installation, operation and maintenance. Keep this Manual for later reference.

This appliance is designed to accumulate thermal energy and distribute it subsequently. It must be connected to a heating system and heat sources. This appliance is suitable for continuous heating of domestic hot water.

Using the thermal store for other purposes than above described is forbidden and the manufacturer accepts no responsibility for damage caused by improper or wrong use or filling procedure.

The appliance shall be installed by a qualified person according to valid rules, otherwise the warranty becomes null and void.

3 - Technical Data and Dimensions of HSK PB Thermal Stores

HSK 250 PB Combination Thermal Store

	Main Features	
	Application	Combination thermal store with integrated stainless-steel heat exchanger and a tight separating metal sheet is intended for heat accumulation and DHW heating. Thanks to its modified design and the tight separating metal sheet, just one zone valve is sufficient for switching between heating the upper and lower tank sections. The tank is suitable for installations with heat pumps and RegulusBOX indoor unit. The tank insulation is not included in supply and shall be ordered separately, see the code below.
	Working fluid	Water (heat exchanger), water; water-glycol mixture (max. 1:1) or water/glycerine mixture (max. 2:1 (thermal store)).
	Thermal store code	20294
	Insulation code	20296

Energy Efficiency Data (as per EC Regulation No. 812/2013)

	valid for a thermal store with insulation
Energy efficiency class	C
Static loss	71 W
Storage volume	260 l

Technical data

Total thermal store volume	260 l
Fluid volume in thermal store	239 l
Fluid volume above separating plate	175 l
Fluid volume below separating plate	64 l
Fluid volume of DHW heat exchanger above the separating plate	21.0 l
Surface area of DHW heat exchanger above the separating plate	6.0 m ²
Max. working temperature in thermal store	95 °C
Max. working temperature in DHW heat exchanger	95 °C
Max. working pressure in thermal store	4 bar
Max. working pressure in DHW heat exchanger	10 bar
Thermal store diameter	450 mm
Thermal store diameter with insulation	650 mm
Thermal store overall height	1850 mm
Tipping height without insulation	1860 mm
Thermal store perimeter insulation thickness	100 mm
Thermal store bottom insulation thickness	50 mm
Thermal store top insulation thickness	120 mm
Empty weight without insulation	78 kg

Accessories

Electric heating element	types ETT-A, D2, R, S, C, F2, M, P, U
Heating element max. length	500 mm

HSK 250 PB Combination Thermal Store

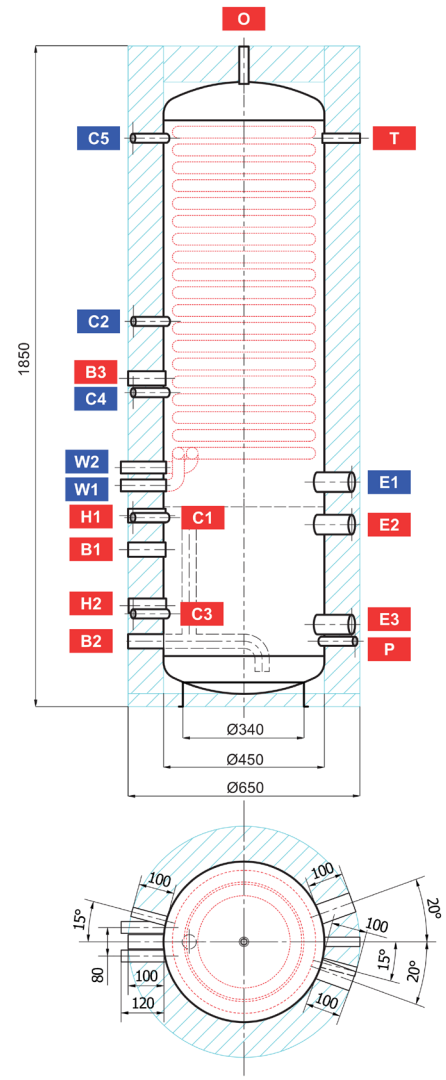
Dimensions		CONNECTIONS																																																																																																			
	<table border="1" style="width: 100%; border-collapse: collapse;"> <thead> <tr style="background-color: #cccccc;"> <th style="text-align: left; padding: 2px;">pos.</th> <th style="text-align: left; padding: 2px;">description</th> <th style="text-align: left; padding: 2px;">connection</th> <th style="text-align: left; padding: 2px;">height [mm]</th> </tr> </thead> <tbody> <tr style="background-color: #cccccc;"> <td colspan="4" style="padding: 2px;">Heat sources</td> </tr> <tr> <td style="background-color: #ff0000; color: white;">B1</td> <td style="padding: 2px;">Supply from heat source</td> <td style="padding: 2px;">G 1" F</td> <td style="padding: 2px;">440</td> </tr> <tr> <td style="background-color: #ff0000; color: white;">B2</td> <td style="padding: 2px;">Return to heat source</td> <td style="padding: 2px;">G 1" F</td> <td style="padding: 2px;">183</td> </tr> <tr> <td style="background-color: #ff0000; color: white;">B3</td> <td style="padding: 2px;">Supply from heat source</td> <td style="padding: 2px;">G 1" F</td> <td style="padding: 2px;">920</td> </tr> <tr style="background-color: #cccccc;"> <td colspan="4" style="padding: 2px;">Heating system</td> </tr> <tr> <td style="background-color: #ff0000; color: white;">H1</td> <td style="padding: 2px;">Flow to heating system</td> <td style="padding: 2px;">G 1" F</td> <td style="padding: 2px;">536</td> </tr> <tr> <td style="background-color: #ff0000; color: white;">H2</td> <td style="padding: 2px;">Return from heating system</td> <td style="padding: 2px;">G 1" F</td> <td style="padding: 2px;">283</td> </tr> <tr style="background-color: #cccccc;"> <td colspan="4" style="padding: 2px;">Electric heating element</td> </tr> <tr> <td style="background-color: #0000ff; color: white;">E1</td> <td style="padding: 2px;">El. heating element (DHW)</td> <td style="padding: 2px;">G 6/4" F</td> <td style="padding: 2px;">630</td> </tr> <tr> <td style="background-color: #ff0000; color: white;">E2</td> <td style="padding: 2px;">El. heating element (space heating)</td> <td style="padding: 2px;">G 6/4" F</td> <td style="padding: 2px;">510</td> </tr> <tr> <td style="background-color: #ff0000; color: white;">E3</td> <td style="padding: 2px;">El. heating element (space heating)</td> <td style="padding: 2px;">G 6/4" F</td> <td style="padding: 2px;">230</td> </tr> <tr style="background-color: #cccccc;"> <td colspan="4" style="padding: 2px;">DHW heating</td> </tr> <tr> <td style="background-color: #0000ff; color: white;">W1</td> <td style="padding: 2px;">Cold water</td> <td style="padding: 2px;">G 1" M</td> <td style="padding: 2px;">620</td> </tr> <tr> <td style="background-color: #0000ff; color: white;">W2</td> <td style="padding: 2px;">Domestic hot water</td> <td style="padding: 2px;">G 1" M</td> <td style="padding: 2px;">670</td> </tr> <tr style="background-color: #cccccc;"> <td colspan="4" style="padding: 2px;">Control and safety</td> </tr> <tr> <td style="background-color: #ff0000; color: white;">C1</td> <td style="padding: 2px;">Temperature sensor</td> <td style="padding: 2px;">G 1/2" F</td> <td style="padding: 2px;">530</td> </tr> <tr> <td style="background-color: #0000ff; color: white;">C2</td> <td style="padding: 2px;">Temperature sensor</td> <td style="padding: 2px;">G 1/2" F</td> <td style="padding: 2px;">1080</td> </tr> <tr> <td style="background-color: #ff0000; color: white;">C3</td> <td style="padding: 2px;">Temperature sensor</td> <td style="padding: 2px;">G 1/2" F</td> <td style="padding: 2px;">260</td> </tr> <tr> <td style="background-color: #0000ff; color: white;">C4</td> <td style="padding: 2px;">Temperature sensor</td> <td style="padding: 2px;">G 1/2" F</td> <td style="padding: 2px;">880</td> </tr> <tr> <td style="background-color: #0000ff; color: white;">C5</td> <td style="padding: 2px;">Temperature sensor</td> <td style="padding: 2px;">G 1/2" F</td> <td style="padding: 2px;">1593</td> </tr> <tr> <td style="background-color: #ff0000; color: white;">T</td> <td style="padding: 2px;">Thermometer</td> <td style="padding: 2px;">G 1/2" F</td> <td style="padding: 2px;">1593</td> </tr> <tr> <td style="background-color: #ff0000; color: white;">P</td> <td style="padding: 2px;">Safety valve</td> <td style="padding: 2px;">G 1/2" F</td> <td style="padding: 2px;">183</td> </tr> <tr style="background-color: #cccccc;"> <td colspan="4" style="padding: 2px;">Air discharge</td> </tr> <tr> <td style="background-color: #ff0000; color: white;">O</td> <td style="padding: 2px;">Air vent valve</td> <td style="padding: 2px;">G 1/2" F</td> <td style="padding: 2px;">1850</td> </tr> </tbody> </table>	pos.	description	connection	height [mm]	Heat sources				B1	Supply from heat source	G 1" F	440	B2	Return to heat source	G 1" F	183	B3	Supply from heat source	G 1" F	920	Heating system				H1	Flow to heating system	G 1" F	536	H2	Return from heating system	G 1" F	283	Electric heating element				E1	El. heating element (DHW)	G 6/4" F	630	E2	El. heating element (space heating)	G 6/4" F	510	E3	El. heating element (space heating)	G 6/4" F	230	DHW heating				W1	Cold water	G 1" M	620	W2	Domestic hot water	G 1" M	670	Control and safety				C1	Temperature sensor	G 1/2" F	530	C2	Temperature sensor	G 1/2" F	1080	C3	Temperature sensor	G 1/2" F	260	C4	Temperature sensor	G 1/2" F	880	C5	Temperature sensor	G 1/2" F	1593	T	Thermometer	G 1/2" F	1593	P	Safety valve	G 1/2" F	183	Air discharge				O	Air vent valve	G 1/2" F	1850
	pos.	description	connection	height [mm]																																																																																																	
Heat sources																																																																																																					
B1	Supply from heat source	G 1" F	440																																																																																																		
B2	Return to heat source	G 1" F	183																																																																																																		
B3	Supply from heat source	G 1" F	920																																																																																																		
Heating system																																																																																																					
H1	Flow to heating system	G 1" F	536																																																																																																		
H2	Return from heating system	G 1" F	283																																																																																																		
Electric heating element																																																																																																					
E1	El. heating element (DHW)	G 6/4" F	630																																																																																																		
E2	El. heating element (space heating)	G 6/4" F	510																																																																																																		
E3	El. heating element (space heating)	G 6/4" F	230																																																																																																		
DHW heating																																																																																																					
W1	Cold water	G 1" M	620																																																																																																		
W2	Domestic hot water	G 1" M	670																																																																																																		
Control and safety																																																																																																					
C1	Temperature sensor	G 1/2" F	530																																																																																																		
C2	Temperature sensor	G 1/2" F	1080																																																																																																		
C3	Temperature sensor	G 1/2" F	260																																																																																																		
C4	Temperature sensor	G 1/2" F	880																																																																																																		
C5	Temperature sensor	G 1/2" F	1593																																																																																																		
T	Thermometer	G 1/2" F	1593																																																																																																		
P	Safety valve	G 1/2" F	183																																																																																																		
Air discharge																																																																																																					
O	Air vent valve	G 1/2" F	1850																																																																																																		

HSK 650 PB Combination Thermal Store

	Main Features	
	Application	Combination thermal store with integrated stainless-steel heat exchanger and a tight separating metal sheet is intended for heat accumulation and DHW heating. Thanks to its modified design and the tight separating metal sheet, just one zone valve is sufficient for switching between heating the upper and lower tank sections. The tank is suitable for installations with heat pumps and RegulusBOX indoor unit. The tank insulation is not included in supply and shall be ordered separately, see the code below.
	Working fluid	Water (heat exchanger), water; water-glycol mixture (max. 1:1) or water/glycerine mixture (max. 2:1 (thermal store)).
	Thermal store code	19633
	Insulation code	19635

Energy Efficiency Data (as per EC Regulation No. 812/2013)	
	valid for a thermal store with insulation
Energy efficiency class	N/A
Static loss	112 W
Storage volume	625 l

Technical data	
Total thermal store volume	625 l
Fluid volume in thermal store	604 l
Fluid volume above separating plate	312 l
Fluid volume below separating plate	292 l
Fluid volume of DHW heat exchanger above the separating plate	21.0 l
Surface area of DHW heat exchanger above the separating plate	6.0 m ²
Max. working temperature in thermal store	95 °C
Max. working temperature in DHW heat exchanger	95 °C
Max. working pressure in thermal store	4 bar
Max. working pressure in DHW heat exchanger	10 bar
Thermal store diameter	750 mm
Thermal store diameter with insulation	950 mm
Thermal store overall height	1725 mm
Tipping height without insulation	1880 mm
Thermal store perimeter insulation thickness	100 mm
Thermal store bottom insulation thickness	50 mm
Thermal store top insulation thickness	120 mm
Empty weight without insulation	115 kg

Accessories	
Electric heating element	types ETT-A, D2, R, S, C, F2, M, P, U
Heating element max. length	755 mm

HSK 650 PB Combination Thermal Store

Dimensions

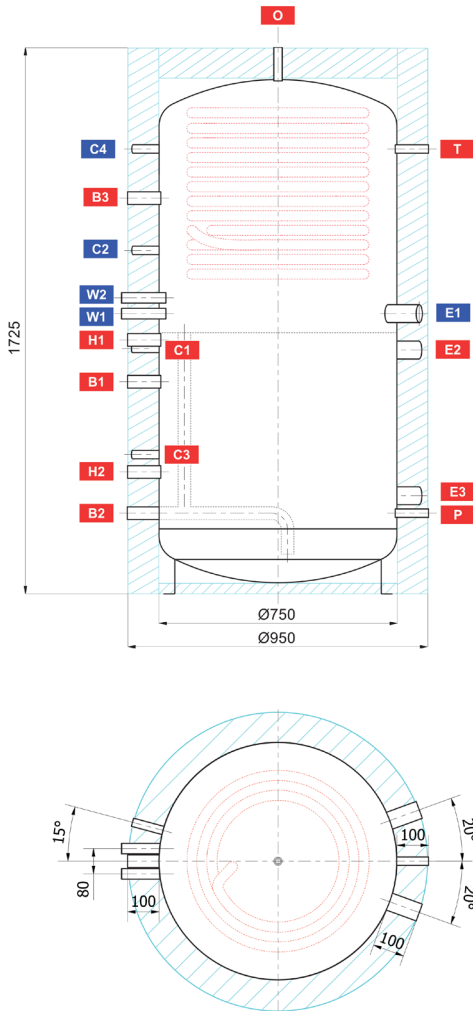

CONNECTIONS

pos.	description	connection	height [mm]
Heat sources			
B1	Supply from heat source	G 1" F	670
B2	Return to heat source	G 1" F	255
B3	Supply from heat source	G 1" F	1250
Heating system			
H1	Flow to heating system	G 1" F	802
H2	Return from heating system	G 1" F	385
Electric heating element			
E1	El. heating element (DHW)	G 6/4" F	885
E2	El. heating element (space heating)	G 6/4" F	770
E3	El. heating element (space heating)	G 6/4" F	310
DHW heating			
W1	Cold water	G 1" M	885
W2	Domestic hot water	G 1" M	935
Control and safety			
C1	Temperature sensor	G 1/2" F	775
C2	Temperature sensor	G 1/2" F	1085
C3	Temperature sensor	G 1/2" F	440
C4	Temperature sensor	G 1/2" F	1405
T	Thermometer	G 1/2" F	1405
P	Safety valve	G 1/2" F	255
Air discharge			
O	Air vent valve	G 1/2" F	1725

4 - Operation

This tank is designed for storing thermal energy for heating in closed pressure circuits with forced circulation. The stored heating water energy is transferred to domestic hot water via the integrated heat exchanger. Hot water is thus heated in a continuous manner.

The tank is suitable for installations with heat pumps and a RegulusBOX indoor unit.

5 - Connection of HSK PB to a Heating System

5.1 HSK 250 PB

KEY

- 1 – Regulus heat pump (RTC, CTC)
- 2 – heating system expansion vessel
- 3 – HSK 250 PB thermal store**
- 4 – PV powered electric heating element (optional)
- 5 – pump station for heating system 2 - CSE2 MIX
- 6 – pump station for heating system 1 - CSE2
- 7 – collector/manifold, HV 60/125-2
- 8 – pump station for DHW recirculation – CSE TVMIX ZV
- 9 – safety kit for HW storage tank
- 10 – DHW expansion vessel
- 11 – RegulusBOX indoor unit
- SV – cold water
- TV – hot water
- CV – hot water recirculation
- UT – central heating (heating system)
- KK – ball valve
- ZV – check valve
- AOV – automatic air vent valve
- BVTS – safety relief valve of boiler cooling loop
- REDV – pressure reducing valve (optional)
- VK – drain valve
- SVE – expansion vessel service valve
- PV-UT – safety valve for heating system
- MFB – Magnet Filterball

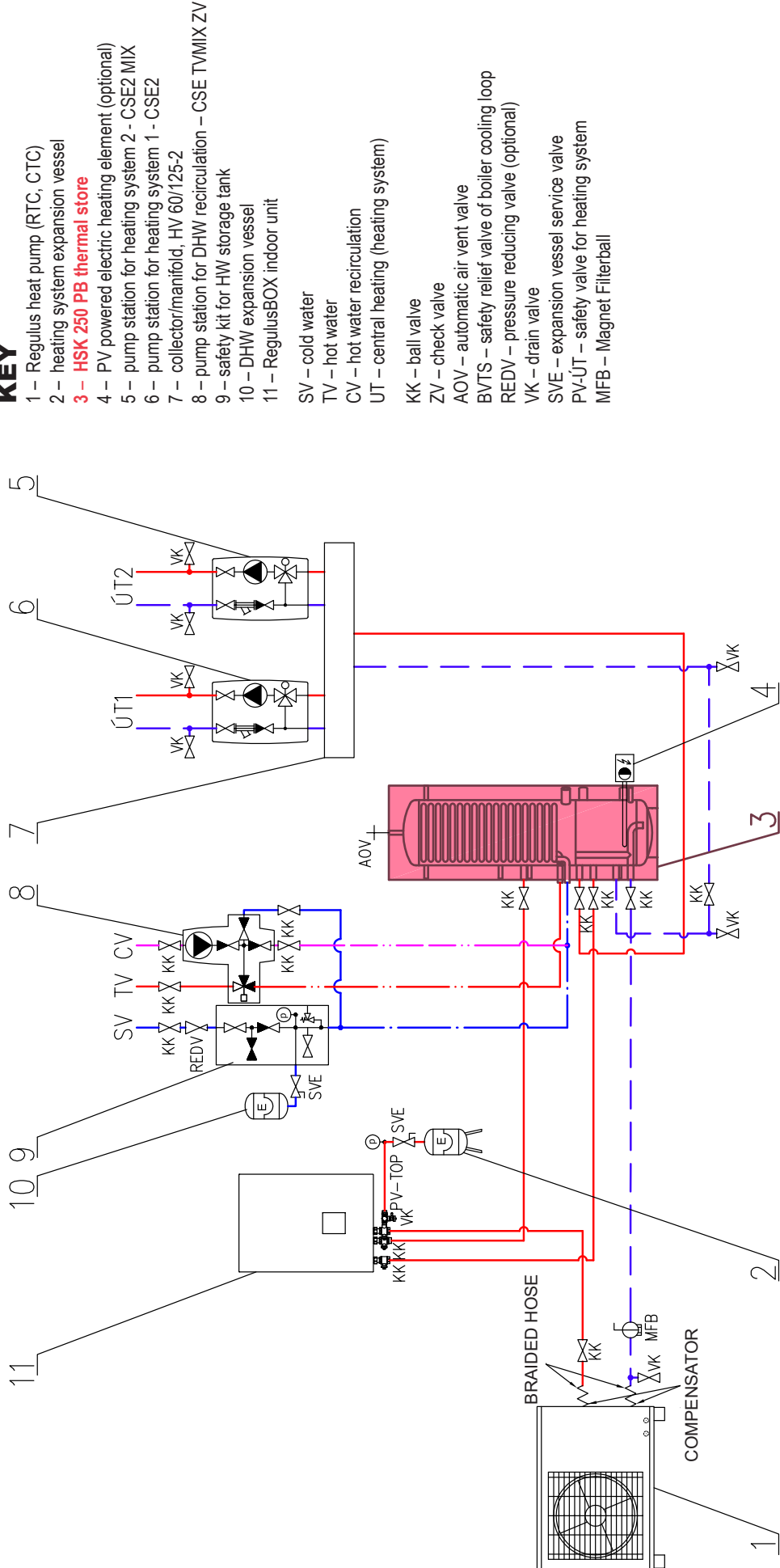

5.2 HSK 650 PB

KEY

- 1 – Regulius heat pump (RTC, CTC)
- 2 – heating system expansion vessel
- 3 – **HSK 650 PB thermal store**
- 4 – PV powered electric heating element (optional)
- 5 – boiler load unit - thermostatic
- 6 – biomass fireplace insert/stove
- 7 – pump station for heating system 2 - CSE2 MIX
- 8 – pump station for heating system 1 - CSE2
- 9 – collector/manifold, HV 60/125-2
- 10 – pump station for DHW recirculation – CSE TVMIX ZV
- 11 – safety kit for HW storage tank
- 12 – DHW expansion vessel
- 13 – RegulusBOX indoor unit

- SV – cold water
 TV – hot water
 CV – hot water recirculation
 UT – central heating (heating system)

- KK – ball valve
 ZV – check valve
 AOV – automatic air vent valve
 BVTS – safety relief valve of boiler cooling loop
 REDV – pressure reducing valve (optional)
 VK – drain valve
 SVE – expansion vessel service valve
 PV-UT – safety valve for heating system
 MFB – Magnet Filterball

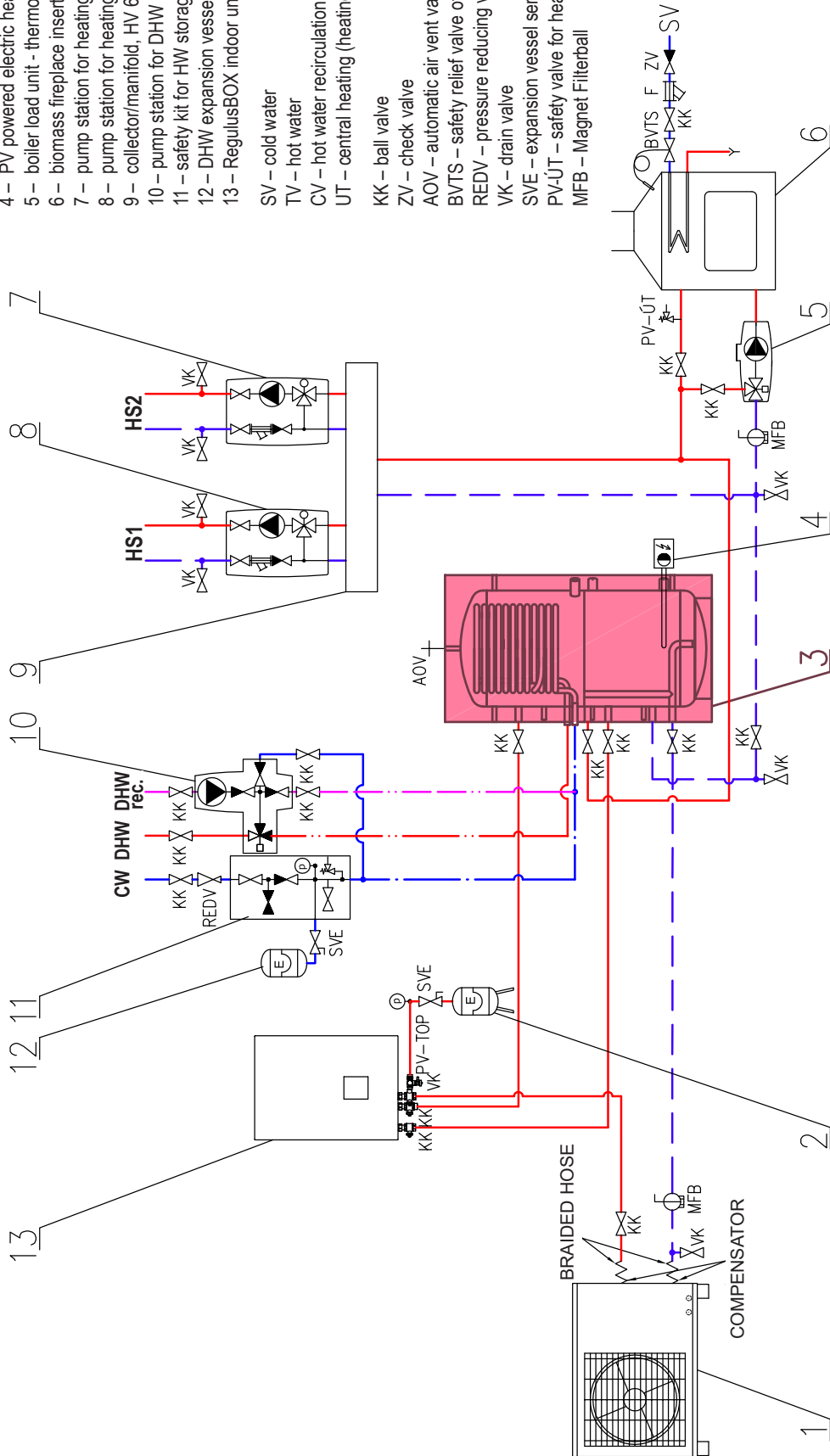

6 - Installation and Commissioning

Installation must meet valid rules and may be done only by qualified staff.

Defects caused by improper installation, use or handling are not covered by warranty.

After the tank is installed and connected to an existing heating system, it is recommended to clean the entire heating system using a suitable cleaning agent, e.g. BP 400.

Anti-corrosion protective liquid should be also used, e.g. BP 100 Plus.

6.1 - Connection to heat sources

Place the tank on the floor and level it. Fit the insulation, see Installing Insulation on the Tank. Connect the heating system according to the diagram of recommended connection - see Chap. 5. Install a drain valve at the lowest point of the tank. Install an air vent valve at the highest point of the system. Insulate all the connection piping.

6.2 - Connection to water mains

DHW piping shall be done according to valid rules. The connections of the tank including the location of components is shown in the recommended connection diagram in chapter 5. Installation of a pressure reducing valve on the tank inlet is recommended. For water mains pressure above 6 bar a pressure reducing valve is necessary. Install a DHW expansion vessel of at least 2 l volume at the cold water inlet. The installation of an expansion vessel is a precondition for the validity of the warranty. Should the water be too hard, install a water softener before the tank. In case the water contains mechanical impurities, install a filter.

Table of limit values for total dissolved solids in hot water

Description	pH	Total dissolved solids (TDS)	Ca	Chlorides	Mg	Na	Fe
max. value	6,5 - 9,5	600 mg/l	40 mg/l	100 mg/l	20 mg/l	200 mg/l	0,2 mg/l

6.3 - Commissioning

Ground the tank before commissioning.

The tank shall be filled up together with the heating system, respecting valid standards and rules. The quality of heating water depends on the quality of filling water at commissioning, on the top-up water and on the frequency of topping up. This has a strong influence on the lifetime of heating systems. Poor quality of heating water may cause problems like corrosion or incrustation, esp. on heat transfer surfaces. In order to minimize corrosion, special additives for heating systems should be used.

Quality of DHW shall meet the conditions shown in the Table of limit values for total dissolved solids in hot water on this page.

Fill the heating circuits with the appropriate fluids and air-bleed the entire system. Check all connections for leaks and verify the system pressure. Set the heating controller in compliance with the documentation and manufacturer's recommendations. Check regularly the proper function of all control and adjustment elements.

7 - Installing Insulation on the Tank

Product description

Thermal insulation is a part of thermal stores, preventing heat loss. For easier handling, the insulation shall not be fitted on the tank until it reaches its definite place of installation.

Warning

Insulation installation shall be done in two persons. Do not use any tools for installation. Keep away from open fire.

Installing Insulation

1. Fix the tank following installation instructions.
2. Wrap the insulation around the tank carefully. Check that the insulation adheres to its body perfectly. This can be reached by rubbing and patting the insulation by hand from its center evenly in both directions until the insulation adheres to the tank's surface completely and no bubbles are left.
3. Use the holes for connections as a rest during the insulation installation.
4. At least one person presses the insulation to the tank, pulling both ends together. The other person closes the insulation lock from the side.
5. Put on the upper insulation and cover.
6. Push on the covering plastic rosettes depending on the size of connections.
7. Finish the tank installation in compliance with the respective instructions and valid standards and rules.

Warranty on insulation

- Warranty shall become null and void if:
 - the procedure described in the Installation Manual was not respected
 - the product was used for other purposes than intended.
- Warranty does not cover:
 - usual wear and tear,
 - damage caused by fire, water, electricity or a natural disaster,

- defects caused by failure to use the product in compliance with its intended purpose, by improper use and insufficient maintenance,
- defects caused by mechanical damage to the product,
- defects caused by tampering or incompetent repair.

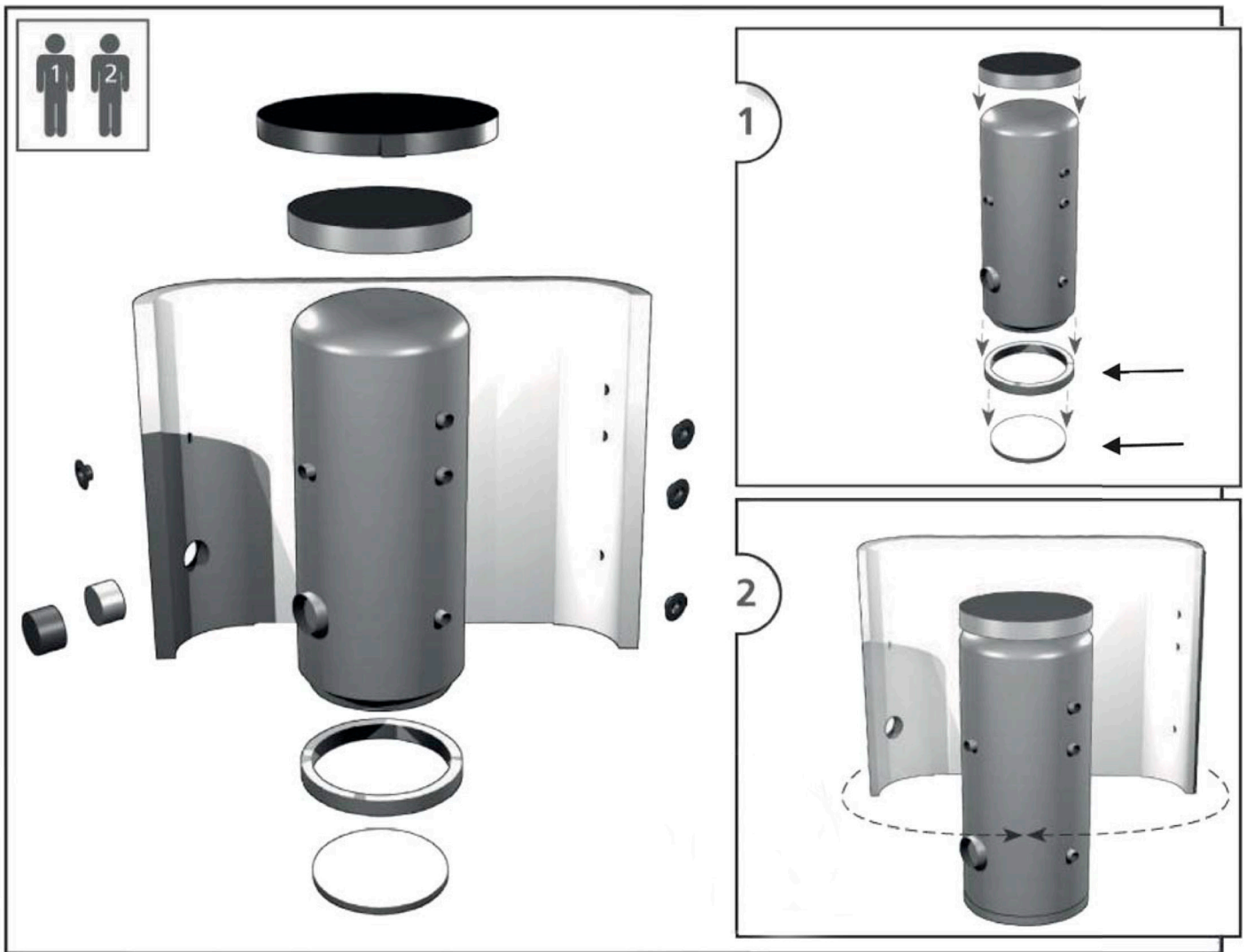

8 - Maintenance

Clean the exterior of the tank with a soft cloth and a mild detergent. Never use abrasive cleaners or solvents. Check all connections for leaks.

9 - Disposal

Packaging shall be disposed of in compliance with the valid rules. When the product reaches the end of its life, it shall not be disposed of as household waste. It shall be dropped off at a Local Waste Recycling Center. Insulation shall be recycled as plastic and the steel vessel as scrap iron.

10 - Warranty

This product is covered by warranty under conditions specified in this Manual and the respective Warranty Certificate. The Warranty Certificate is an integral part of supply of this Thermal Store.

