

MODVLVS

Two-line Solar Pump Station

S2 Solar 2 and S2 Solar 3

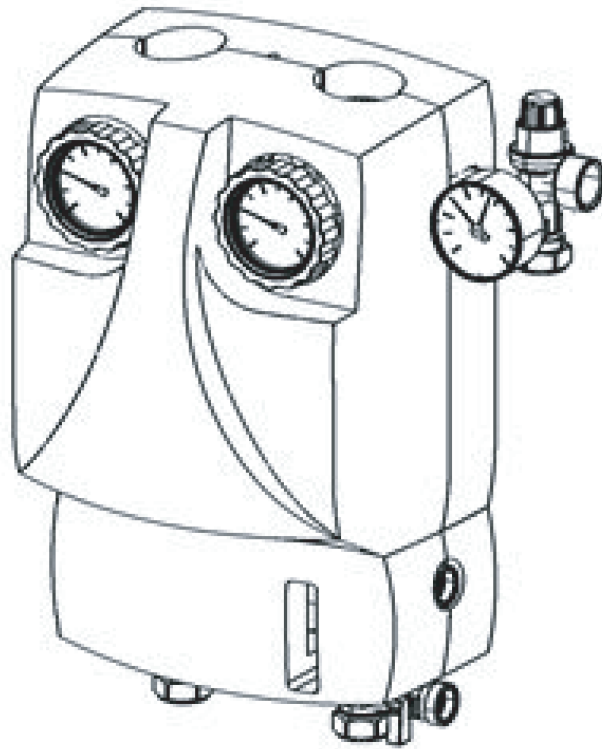

Regulus

MODVLVS Two-line Solar Pump Station "S2 Solar 2"

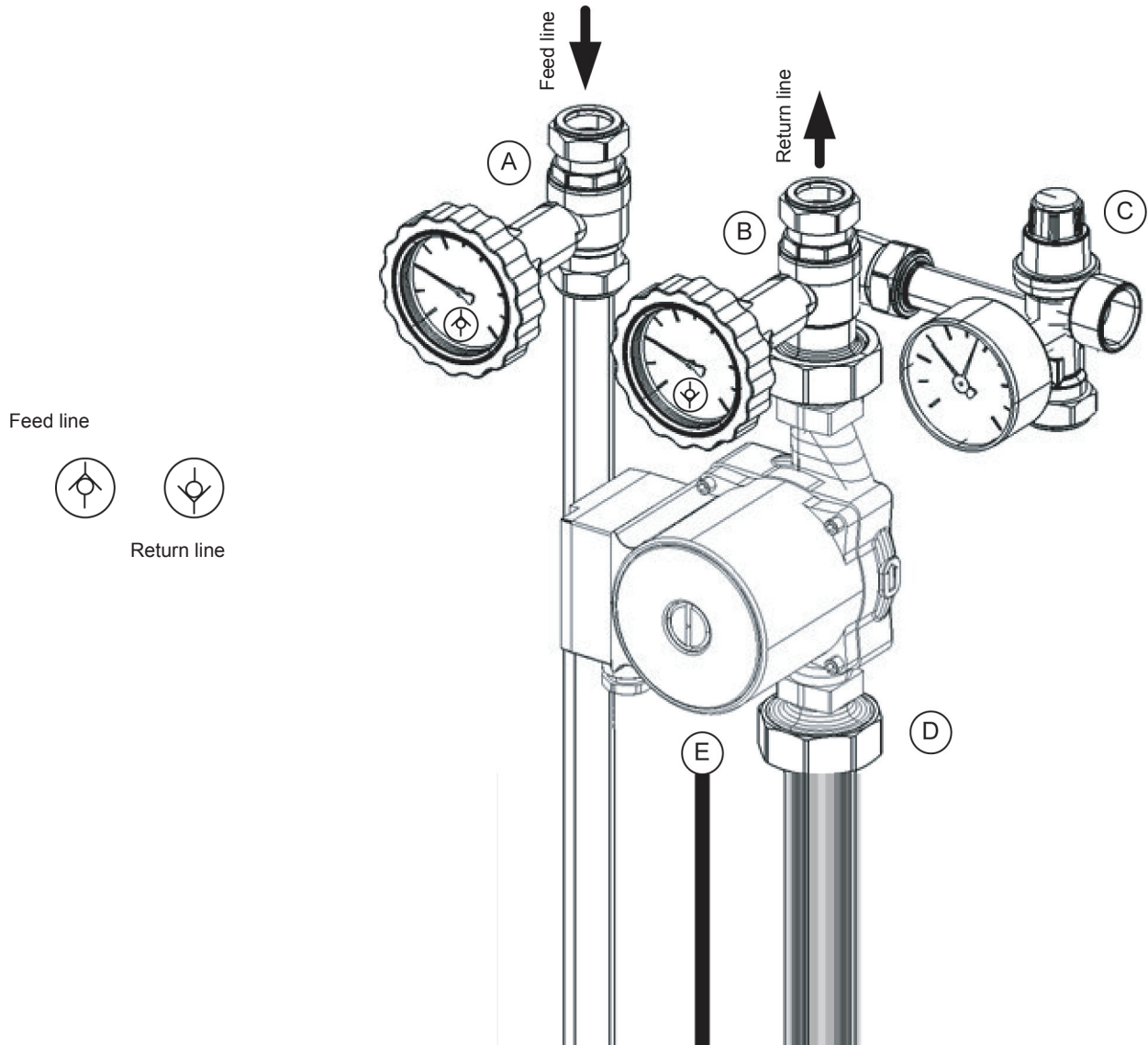

(A) Ball valve on the feed line (thermometer with a red ring and scale 0-120°C) with "Solar" check valve.

(B) Ball valve on the return line (thermometer with a blue ring and scale 0-120°C) with "Solar" check valve.

Solar Check Valve

It is included in the ball valves in both the feed and return lines. It ensures the seal and low head losses. To exclude the check valve, for instance in case of emptying, rotate the handle by 45° clockwise.

(C) Safety Unit

The safety unit, approved according to CE and TÜV, protects the installation from overpressures. It is equipped with a 6bar safety valve. It is also provided with a manometer and with a connection to the expansion vessel by a 22mm pipe with a 3/4" thread or by a 3/4" thread.

(D) Flowmeter

The flowmeter allows to regulate the flow rate depending on the capacity of the installation, by a 3-way valve. The flow rate is measured and shown by a special sliding cursor.

Further it enables the following actions to be taken:

system filling - draining - flushing.

Two flowmeters are available with a different range of measurement: 2-12 l/min and 8-28 l/min.

(E) Circulation pump

Three-speed circulation pump with manual regulation. Thanks to the seal of the ball valves before and after the circulating pump, it can be removed without emptying the installation.

Directions for the use of the flowmeter to fill the installation:

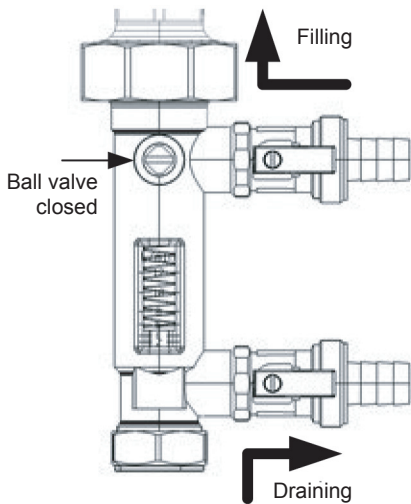

(1) - Filling the installation:

- Attach the filling hose to the filling valve and open it completely.
- Attach the return hose to the drain valve and open it completely.
- Turn the groove on the flowmeter's adjustment screw into a horizontal position. The integrated ball valve will close.
- Pour sufficient solar liquid into the filling station tank (not included in the delivery) and fill the solar system.
- Flush the solar system using the filling station for at least 15 min. In order to remove air from the system completely, open shortly the regulation screw on the flowmeter (groove vertically).

Do not flush the system with water. Since it mostly does not get completely empty, there is a risk of frost damage.

- With the filling pump running, open the drain valve and increase the pressure to approx. 5.5 bar. This value can be read on the manometer.
- Close the filling valve and turn off the filling pump, open the regulation screw on the flowmeter (groove vertically).
- Air bleed the system above collectors until bubble-free solar liquid starts flowing out. Then increase the pressure to approx. 5 bar again and check the system for leaks.
- Adjust the working pressure as given by the collector manufacturer.
- Turn on the circulation pump at its highest speed (see its Instruction Manual) and let circulate for at least 15 min.
- Then air bleed the system and set the pump to the desired speed.

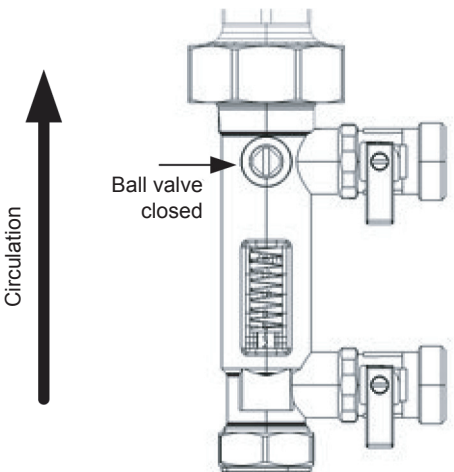

(2) - Commissioning:

- Set a suitable flow rate by the flowmeter according to the data supplied by the collector manufacturer (1-2 l/min. for each flat solar collector).
- Remove the filling station hoses and screw caps on both the filling and drain valves.
- Test the system for leaks once again.

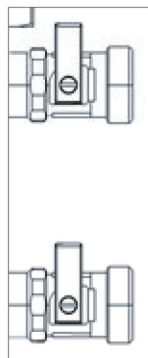

Blocking the filling/drain levers:

Unscrew the fixing screw, take out the lever and place it back turning it by 180°.

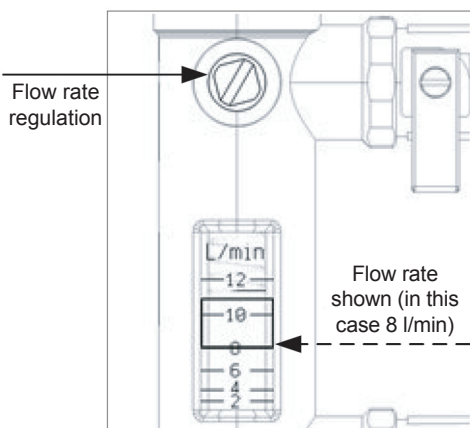

- (3) - Regulate the flow rate using the regulation element on the ball valve until the right flow rate is shown.

N.B.

The flow rate is shown taking as reference the lower edge of the sliding cursor. (see pic.)

MODVLVS Two-line Solar Pump Station “S2 Solar 3”

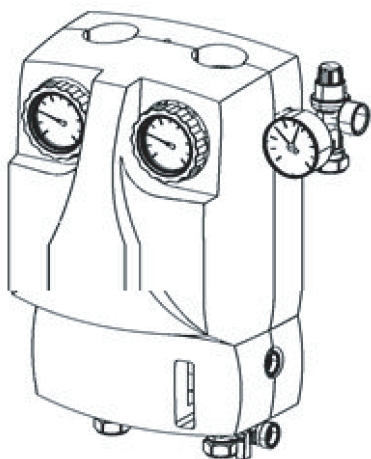

EPP insulation box

Dimensions 250x380x190.

Two covers, one for the circulation pump/valves, the other for the flowmeter. Side opening for the security unit. A special window allows to read and regulate the flow without removing the cover.

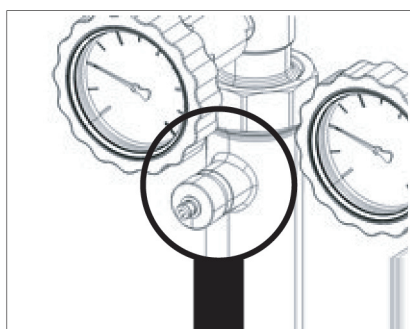

S2 Solar 3 is a model with air vent

An air vent is a device that eliminates continually the air that can be in circulation together with the fluid.

The air goes to the upper part of the air vent and can be eliminated through the special drain while the installation is working.

Unscrew the knurled metal ring lock, let the air bleed and tighten again.

This operation has to be done from time to time.

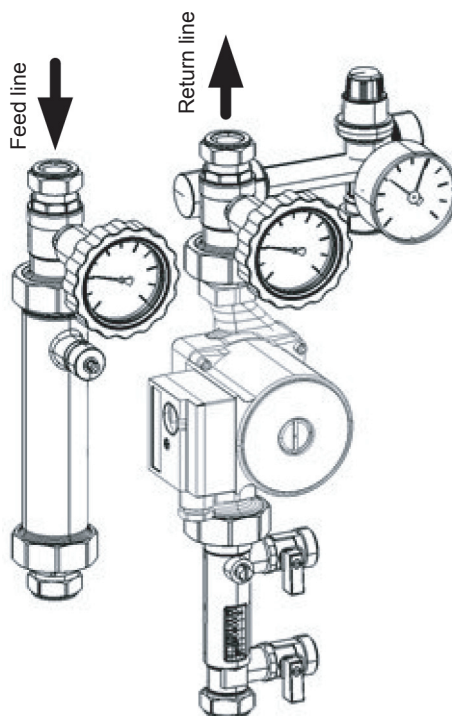

TAKE CARE!

To avoid any leakage of the fluid, taking into consideration the very high working temperature, we recommend to fasten a pipe to the end of the drain.

Instructions for wall mounting:

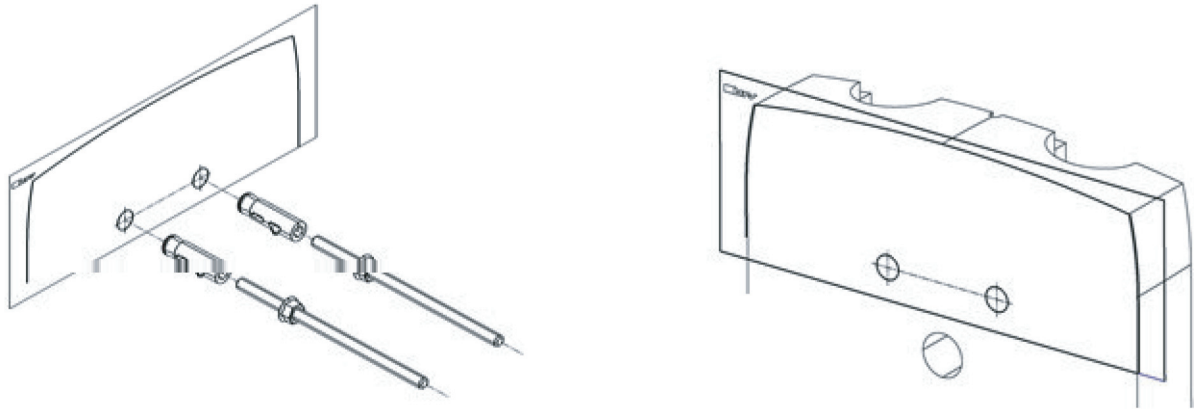

(1) Drilling and wall plugs

Using the enclosed drill template, drill holes into the wall where the bracket shall be placed. Use the enclosed wall plugs \varnothing 14. Screw the threaded rod in the right position and tighten the lock nut. The right position and depth of the holes is shown in the enclosed template. The protrusion from the wall of the threaded rod depends on the desired distance between the wall and the insulation box. For a proper mounting we recommend 135 mm. Put on the rear part of the EPP insulation box.

(2) Back lock nut

Screw the lock nuts on the two threaded rods and place them 30 mm from the end.

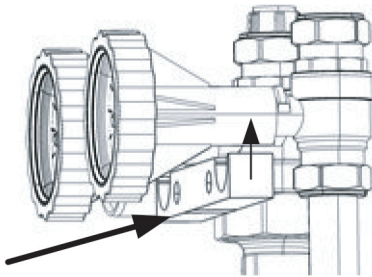

(3) Bracket

The pump station is supported by a bracket. Put the cylindrical part of the bracket into the special seats.

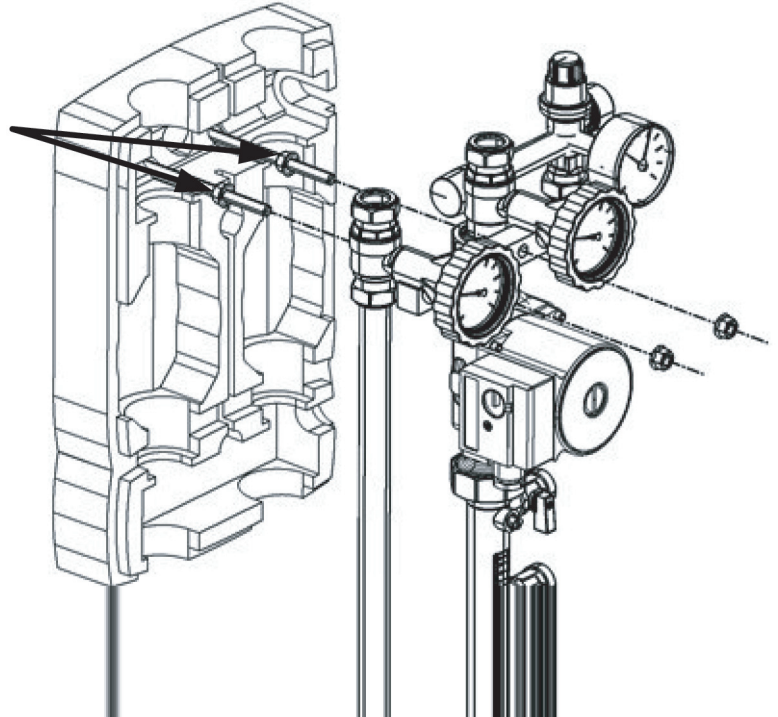

(4) Placing of the pump station

Put the bracket with the pump station already leaned on the threaded rods through the prepared holes. Check the right position on the wall with the drawing in the template. If needed, adjust the two lock nuts as per (2).

Fix the unit screwing the two remaining nuts and fastening the two lock nuts.

Pieces included in the mounting kit

- 1 drilling template with a mounting position sketch
- 2 threaded rods M8x170
- 2 wall plugs \varnothing 14
- 1 bracket
- 6 nuts M8