

BIO 55 MIX - BP G 1 F Load Unit

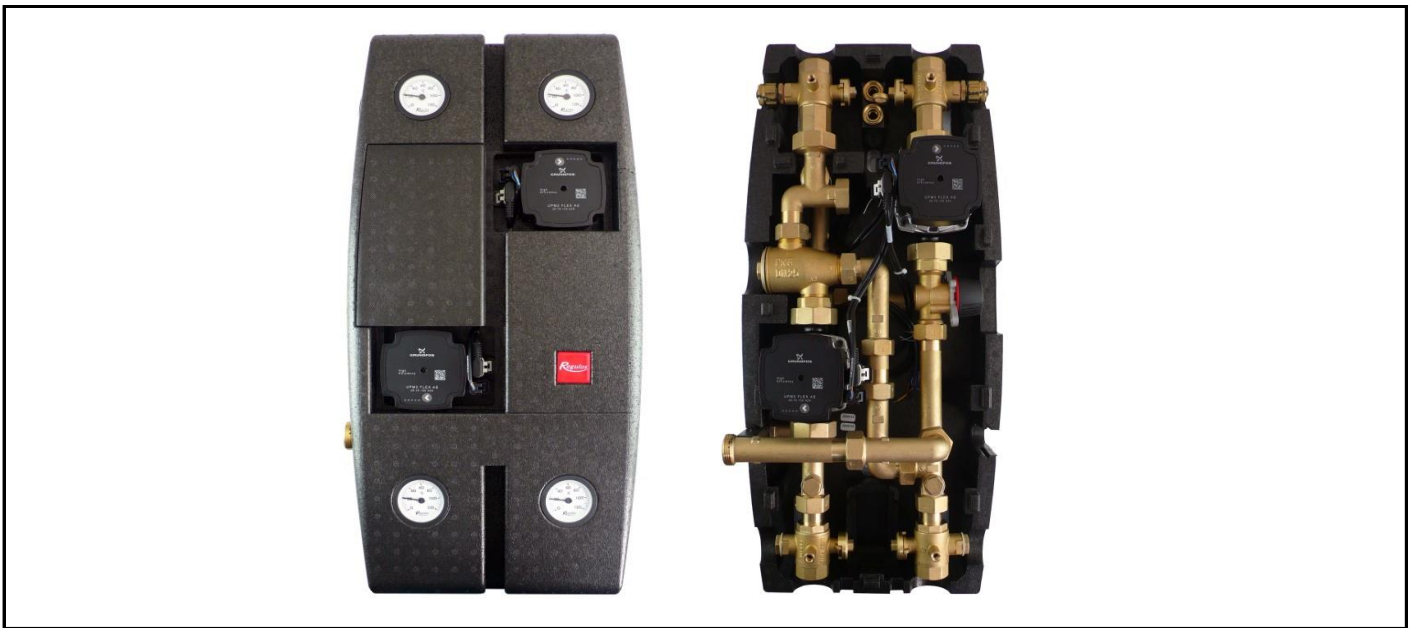

Main Features	
Application	BIO 55 MIX-BP G 1 F Insulated Load Unit is used to connect a heating system with a hydronic fireplace or solid fuel boiler and a thermal store. Heating water is mixed to OTC temperature in a 3-way valve, the return water temperature to boiler is kept at 55°C min. by a load valve in order to prevent low-temperature corrosion in the boiler. The boiler surplus output is stored in the thermal store and drawn later into the heating system if necessary.
Description	<p>The Load Unit includes</p> <ul style="list-style-type: none"> ● two Grundfos UPM3 Flex AS 25-75 circulation pumps (with the possibility of control by a PWM signal or by selecting a pump performance curve) ● TSV3BM load valve with automatic bypass balancing protecting a boiler against low-temperature corrosion by keeping the min. return water temperature to boiler at 55°C ● three-way mixing valve to maintain the required temperature in the heating circuit ● two ball valves with drain valve for shutting off and draining the heating system ● check valve integrated in the ball valve body located at the outlet from the heating system ● two ball valves and to shut off the boiler circuit ● two ball valves permitting to shut off the thermal store circuit (included in supply) ● two drain valves to drain the load unit ● lever for ball valves ● four thermometers ● outlets to connect a thermal store or a combination one, and alternative outlets to connect optional accessories
Working fluid	water, antifreeze heat-transfer fluid for heating systems
Installation	vertically on a wall using the installation kit
Connections	<p>2 x G 1" F to a heating system 2 x G 1" F to a boiler circuit 2 x G 1" F to a thermal store 2 x G 1/2" F alternative outlets to connect optional accessories (if you do not need to use the outputs, they can be plugged with the enclosed plugs)</p>
Max. boiler output	38 kW Δt 20 K
Max. HS output	20 kW Δt 10 K
Code	17553

BIO 55 MIX - BP G 1 F Load Unit

Data for BIO 55 MIX - BP G 1 F Load Unit

Fluid working temperature	5-95°C
Max. working pressure	6 bar
Ambient temperature	5-40°C
Max. relative humidity	95%, non condensing
Power supply	230 V, 50 Hz from external controller
Max. load unit power input	120 W
Insulation material	EPP RG 60 g/l
Overall dimensions (L x W x D)	640 x 250 x 350 mm
Total weight	16.5 kg

Accessories *

		Code
Magnet Filterball 1"	MAGNET FILTERBALL 1" Ball valve with filter and magnet	17405

* not included in supply, shall be ordered separately!

Load Unit Components

Grundfos UPM3 Flex AS 25-75 Pumps

Electric Data

Power supply	230 V, 50 Hz
Power input (min./max.)	2/60 W
Current (min./max)	0.04/0.58 A
IP rating	IP44
Max. speed	5991 rpm
Weighted average power	≤ 28 W
Energy Efficiency Index	≤ 0,2 by EN 16 297/3
Motor protection	not needed
Min. pressure at the suction port to avoid cavitation	0.5 m H ₂ O at 75 °C 5.1 m H ₂ O at 95 °C

Operating Parameters

Max. working pressure	10 bar
Max. ambient temperature	70 °C
Max. relative humidity	95 %, non condensing

Electrical Wiring

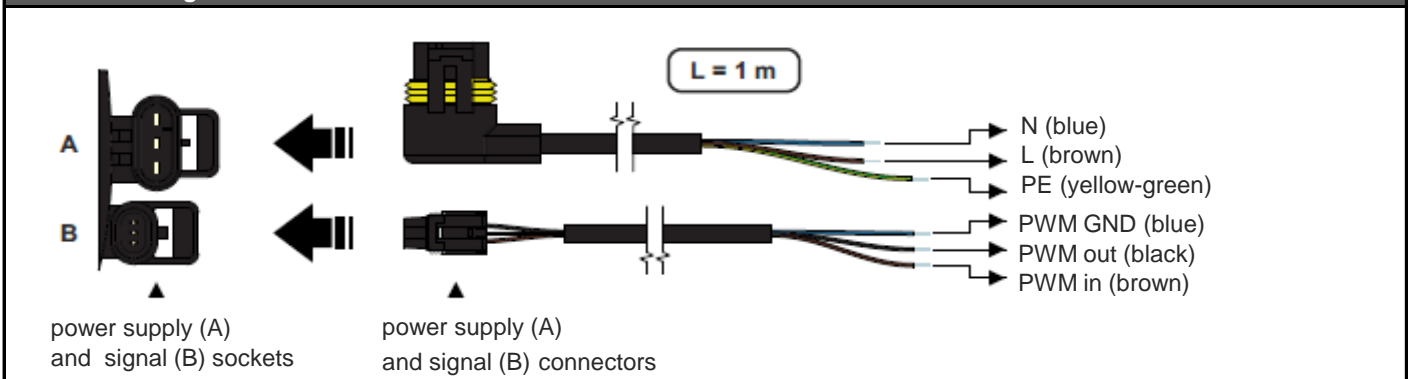

BIO 55 MIX - BP G 1 F Load Unit

Selected profile display during pump operation

control button

curve 1 (4 m)

curve 2 (5 m)

curve 3 (6 m)

curve 4 (7.5 m)



→ when the control button is pressed for less than 2 s, the currently selected curve is shown

→ with no PWM signal the pump runs at max. speed according to the selected curve

→ with PWM signal the pump speed changes with the signal value up to the maximum of the selected curve

UPM3 Flex AS 25-75 Performance Curves

Curve	Max. H (upper graph)	Max. P ₁ (lower graph)
1	4.0 m	25 W
2	5.0 m	33 W
3	6.0 m	39 W
4	7.5 m	60 W

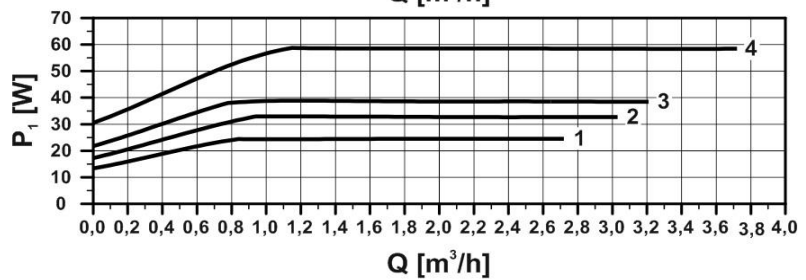
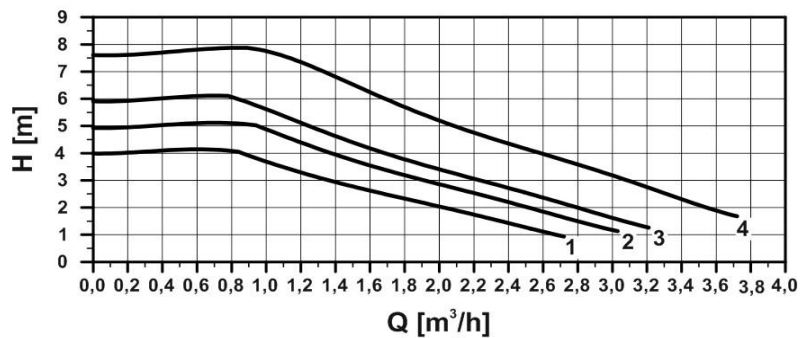

LK 840 Mixing Valve

Technical Data of LK 840 Mixing Valve

Max. pressure difference	5 mH ₂ O
Leak rate	difference
Valve Kvs	6.3 m ³ /h



LK 840 Mixing Valve Pressure Drop Diagram

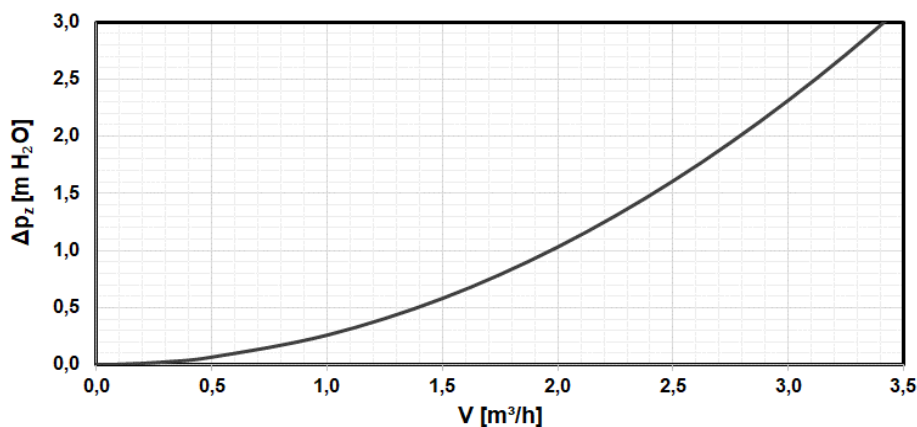

BIO 55 MIX - BP G 1 F Load Unit

TSV3BM Load Valve

Technical Data of TSV3BM Load Valve

Opening temperature	55°C
Kvs value	Direction from A to AB: 9.8 m ³ /h
	Direction from B to AB: 5.3 m ³ /h

TSV3BM Load Valve Pressure Drop Diagram

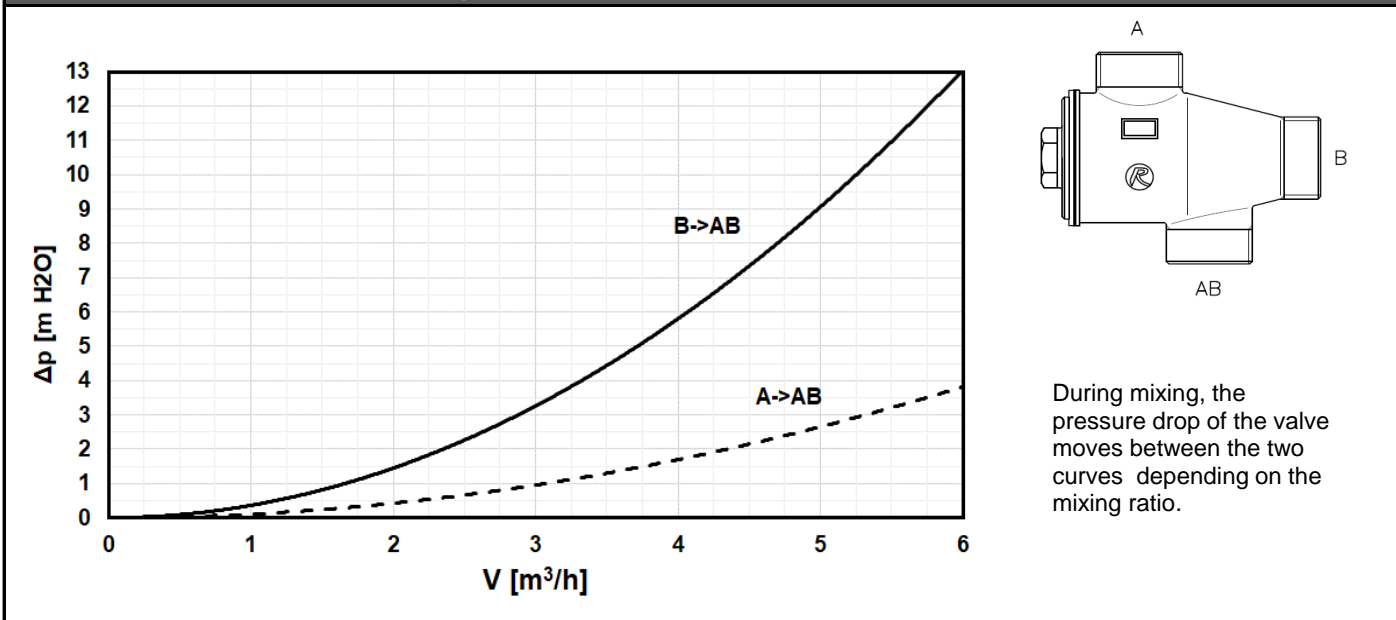

Ball Valve with Check Valve

Ball Valve w. Check Valve Pressure Drop Diagram

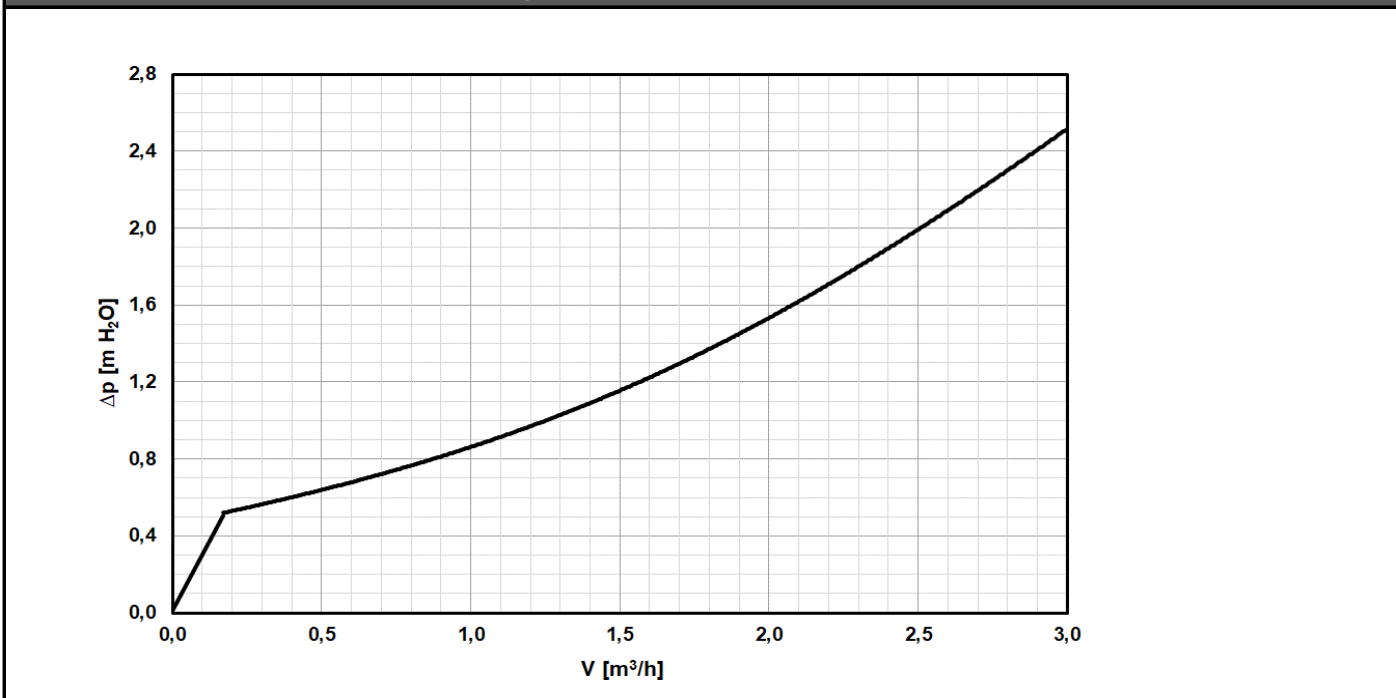

BIO 55 MIX - BP G 1 F Load Unit

Connection Diagram

Variant 2A

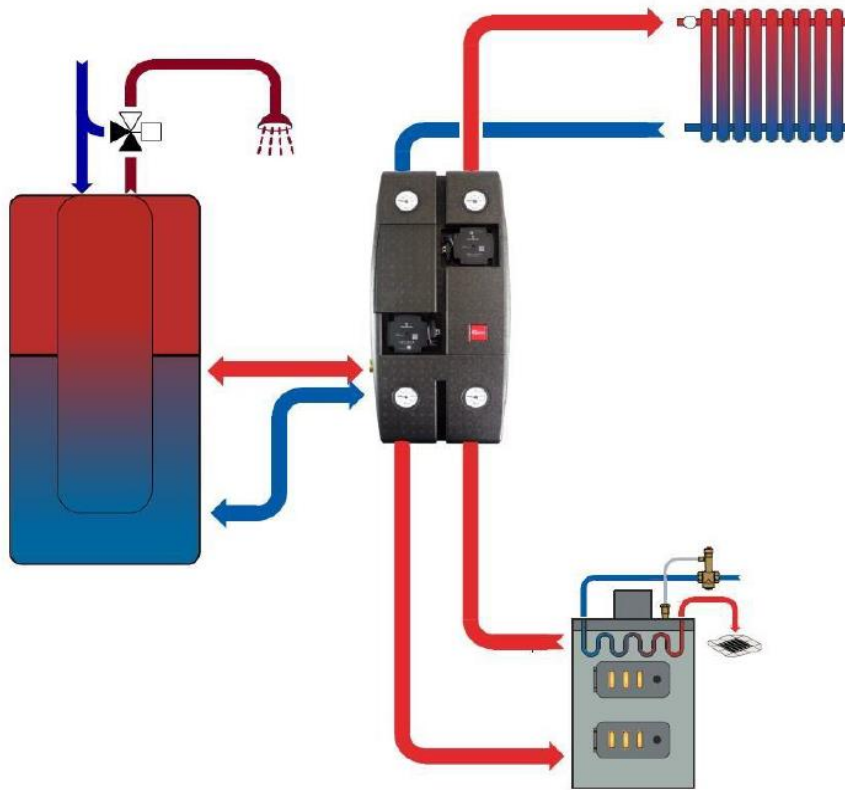

Variant 2B

