

# Regulus

[www.regulus.eu](http://www.regulus.eu)



RGMAT EA W8 5/4

Installation and Operation Manual  
**Regulus RGMAT EA W8 5/4 LOAD UNIT**  
for heating systems

**EN**

**RGMAT EA W8 5/4**

# 1. Introduction

RegulusRGMAT EA W8 5/4 Load Unit makes boiler installation quicker as it contains all components needed for boiler circuit circulation and for boiler protection against low-temperature corrosion. It is designed to be installed directly on a boiler return piping. The distance of pipe axis from a wall shall be at least 100 mm to enable insulation removal if needed. This Load Unit is intended for hydronic fireplaces and solid-fuel boilers.

## 2. Description of the Load Unit

Load Unit RGMAT EA W8 5/4 keeps the temperature in a hydraulic boiler circuit above the flue gas condensation temperatures, which prevents so called low-temperature corrosion of the boiler combustion chamber. This limits condensation and boiler tarring significantly, the efficiency of fuel combustion increases and service life of the boiler is extended.

Main Features	
Function	maintaining a minimum inlet temperature into a boiler (fireplace) through a load valve
Application	Load Unit for solid-fuel boilers and fireplaces; it prevents low-temperature corrosion and boiler (fire) fouling
Description	consists of Wilo PARA 25/8 SC pump, fittings with ball valve, TSV5 valve (with manual by-pass balancing), thermometer and insulation
Working fluid	water; water/glycol mixture (max. 1:1) or water-glycerine mixture (max. 2:1)
Installation	on return pipe, min. pipe centre distance from wall is 100 mm; for proper operation it is necessary to install and adjust a valve at the B inlet to balance flowrate

Code	Max. boiler output
<b>18637</b> for opening temperature 72 °C	50 kW at $\Delta T$ 20 K and fully open balancing valve
<b>18700</b> for opening temperature 65 °C	50 kW at $\Delta T$ 20 K and fully open balancing valve

Data for RGMAT EA W8 5/4 Load Unit	
Fluid working temperature	5 - 95 °C
Max. working pressure	6 bar
Min. working pressure	0.5 bar
Ambient temperature	5 - 40 °C
Max. rel. humidity	80% non condensing
Insulation material	EPP RG 60 g/l
Overall dimensions	305 x 135 x 165 mm
Total weight	3.45 kg
Connections	3x G 5/4" F

Accessories	
Bypass with non-return valve	code 16139

### 3. RGMAT EA W8 5/4 Connection Diagram

#### Example of possible connection I

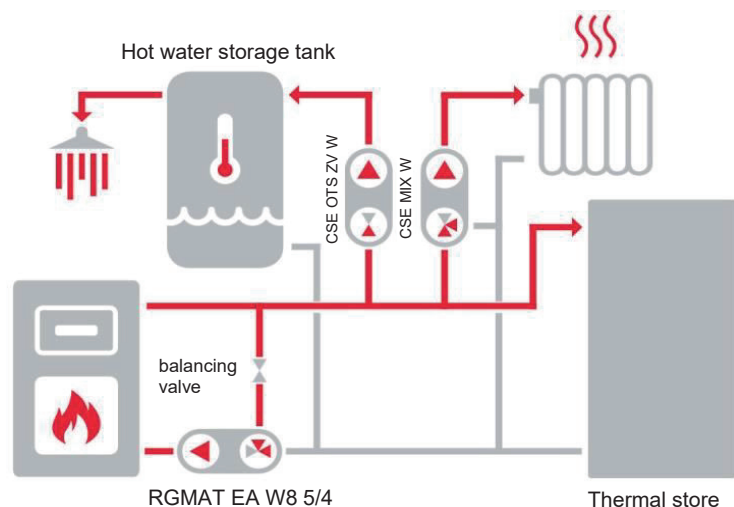

The diagram shows a typical connection of a solid fuel boiler, thermal store and heating circuit (with the recommended CSE MIX W pump station – not included in supply). If the boiler is used also for hot water heating, it is recommended to install a CSE OTS ZV W pump station (not included in supply). A balancing valve shall be installed at the B inlet into the RGMAT EA W8 5/4 pump station.

#### Example of possible connection II

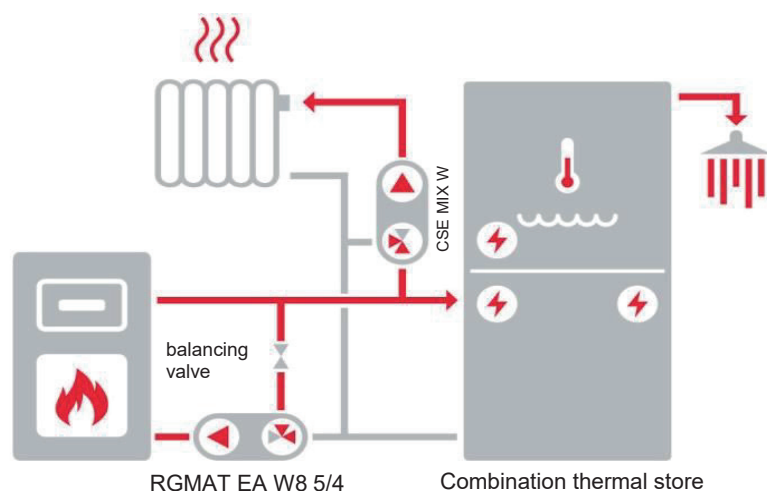

The diagram shows a typical connection of a solid fuel boiler, combination thermal store and heating circuit (with the recommended CSE MIX W pump station – not included in supply). A balancing valve shall be installed at the B inlet into the RGMAT EA W8 5/4 pump station.

#### Install the Load Unit respecting the following instructions:

Connect the Load Unit outlet marked **AB** to the piping entering the boiler. Connect the return line from the heating system to the **A** inlet, and the outlet pipe from the boiler to the **B** inlet via a T-piece. Take care to install shut-off valves where necessary to avoid draining the whole system for valve cleaning or replacing the thermostatic element.

When the connecting pipes are not arranged or sloped properly, the load valve may get blocked by air inside. This may hinder or even disable its operation.

Always respect valid rules and boiler manufacturer's data during installation.

## 4. Function description of TSV5 valve

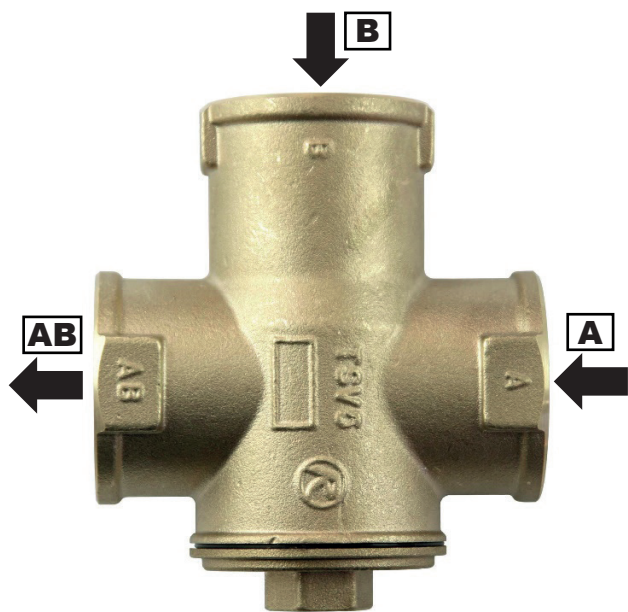

The TSV5 load valve is fitted with an integrated thermostatic insert that will close the **A** inlet (from a heating system), if the return water temperature to the boiler (**AB** outlet) is lower than the opening one. As soon as the opening temperature is reached, the thermostat starts opening the **A** inlet slowly and mixing the cold return water with the hot water from the **B** inlet (boiler flow) with the aim to reach the return temperature (**AB** outlet) slightly higher than the valve opening temperature. The **B** inlet remains always open. However, since the **B** inlet remains permanently open, it may happen depending on the hydraulic conditions that under a higher return temperature more hot water will be mixed from the **B** inlet than necessary for reaching an optimum temperature at **AB** outlet. Under these conditions, the return water temperature will be unnecessarily high. In order to set the optimum flow rate for a specific application, a balancing valve shall be

fitted before the **B** inlet (e.g. a plain ball valve is sufficient). Its size can be two sizes down from the dimension of **B** inlet (like the entire piping between the Tee at the boiler outlet and the **B** inlet), however not bigger than the piping at the **AB** outlet.

### Adjusting the balancing valve:

a. Set the valve to fully open for the first firing. Immediately after firing up, before the return line reaches the opening temperature of the TSV5 valve, set the balancing valve to half open. Let it partially open in such a way that at least the min. flow required by the boiler manufacturer passes through the boiler (usually this corresponds to a temperature drop at the boiler of 20-30 °C at full power). Monitor the boiler flow temperature, it must not exceed the max. operation temperature during the entire temperature ramp, nor after the full output is reached with nominal return temperature. Should the flow temperature rise too high, open the valve a bit more.

b. If the temperature at the **AB** outlet is higher, adjust the valve towards closed. In case the valve cannot be set properly, check the hydraulic system of the system for undesired counter-pressures from another pump or from other wrong connections in the system. Also check that the circulation pump after the **AB** outlet of the valve is set to full power and its performance is suitable for the boiler output.

It is recommended to remove the lever of the balancing valve after balancing in order to avoid possible unintentional shut-off or other movement of the lever.

TSV5 load valve offers fully automatic operation, needs no el. energy, operator or maintenance. When the valve gets clogged with impurities from the system or in case of its breakdown, first close the ball valves on all connecting pipes in order to avoid draining the system. Then loosen the plug using spanner #21 or another suitable tool. Take out the pressure spring of the element and the thermostatic element itself. When re-assembling the valve, take care of the thermostatic element's perfect fit to the gasket with its entire contact surface and its spring being centred within the plug.

# TSV5 Valve

Technical data	
Valve opening temperature	depending on the thermostatic element
Control range	$t_{\text{valve opening}} + 5 \text{ }^{\circ}\text{C}$
Valve Kvs (A→AB direction)	7.0 m <sup>3</sup> /h
Valve Kvs (B→AB direction)*	11.5 m <sup>3</sup> /h
Nominal inner diameter	DN 32

\* when the balancing valve is fully open

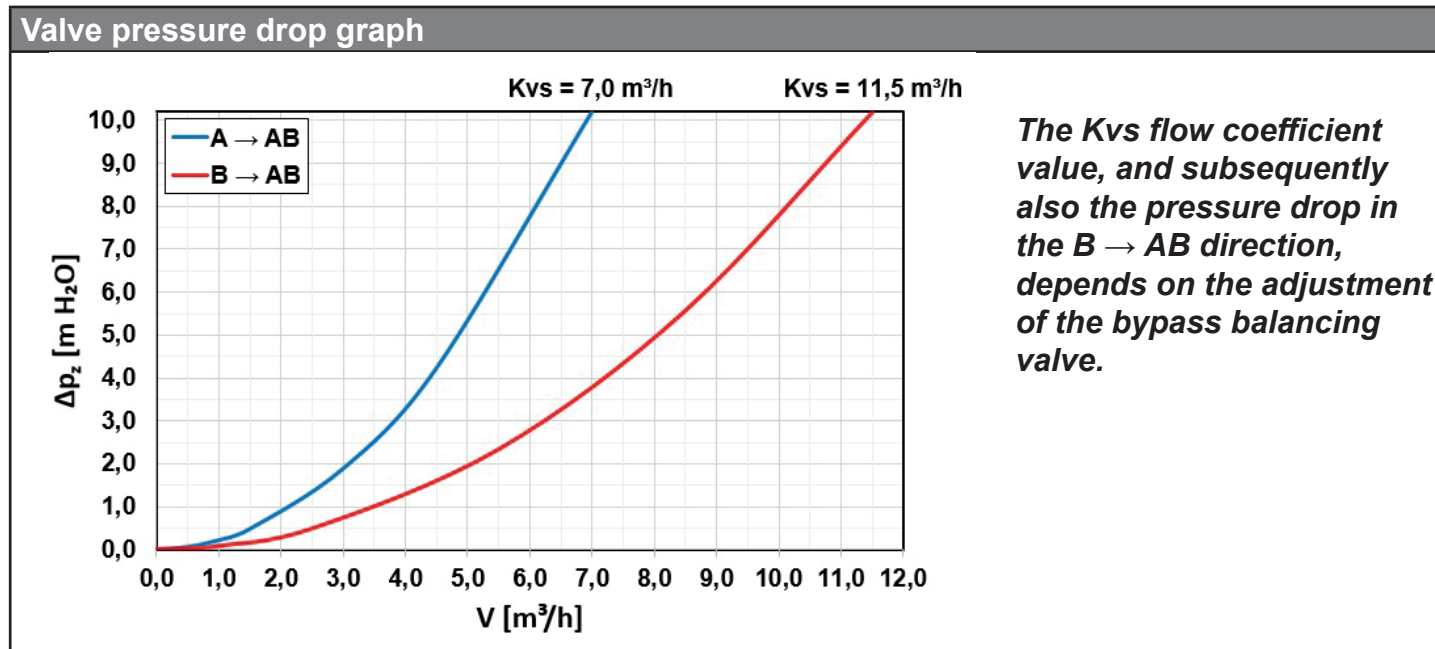

## 5. PARA 25/8 SC 130 mm Pump

### 5.1. General Information

The high efficiency circulation pumps of the PARA SC series are used exclusively for the circulation of liquids in hot water heating systems. Operating the pump in other systems or in systems lacking water, containing air or in unpressurized systems can lead to its rapid destruction.

### 5.2. Pump Description

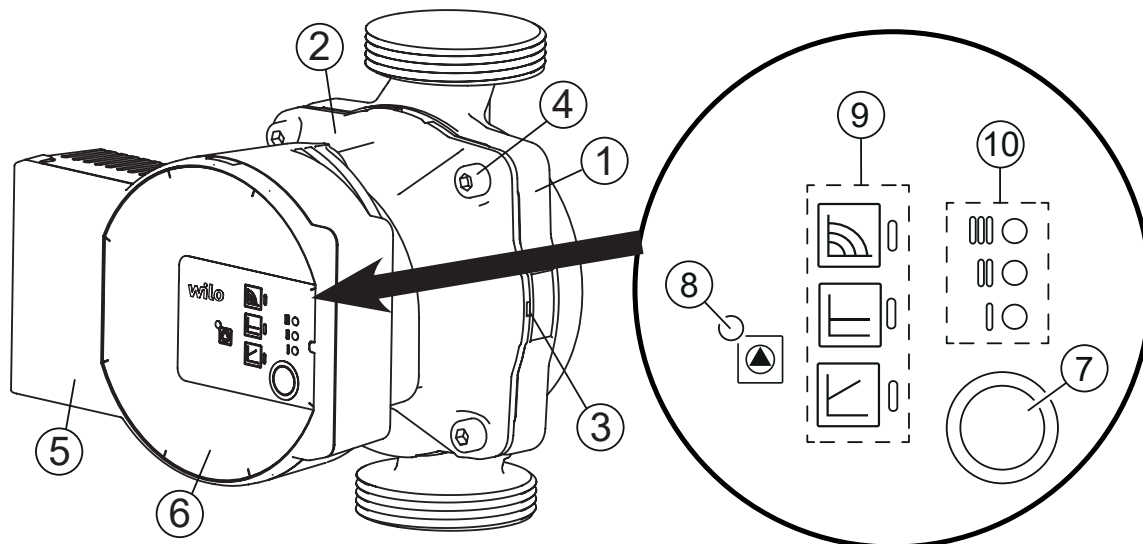

- 1 - Pump housing
- 2 - Pump motor
- 3 - Condensate drain openings
- 4 - Pump housing bolts
- 5 - Control module
- 6 - Rating plate
- 7 - Pump adjustment button
- 8 - LED indication of operation/fault
- 9 - Display of the selected pump operating mode
- 10 - Display of the selected pump curve (I, II, III)

### 5.3. Permitted and Prohibited Load Unit Positions

#### Permitted Positions



#### Prohibited Positions

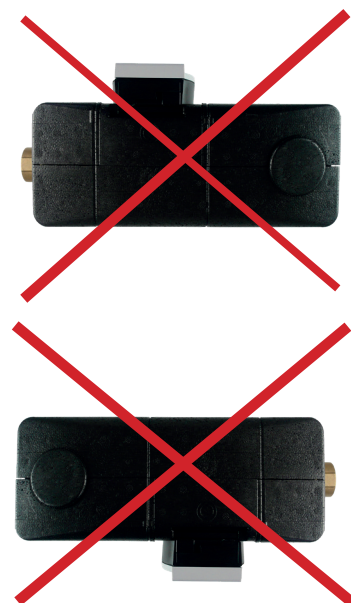

## 5.4. Pump Wiring

The pump shall be wired to electrical installation by a qualified person in compliance with EN 50110-1!

Plug the power cable (2) into the connector on the pump so that the connector lock (1) is in the correct position, see Fig.

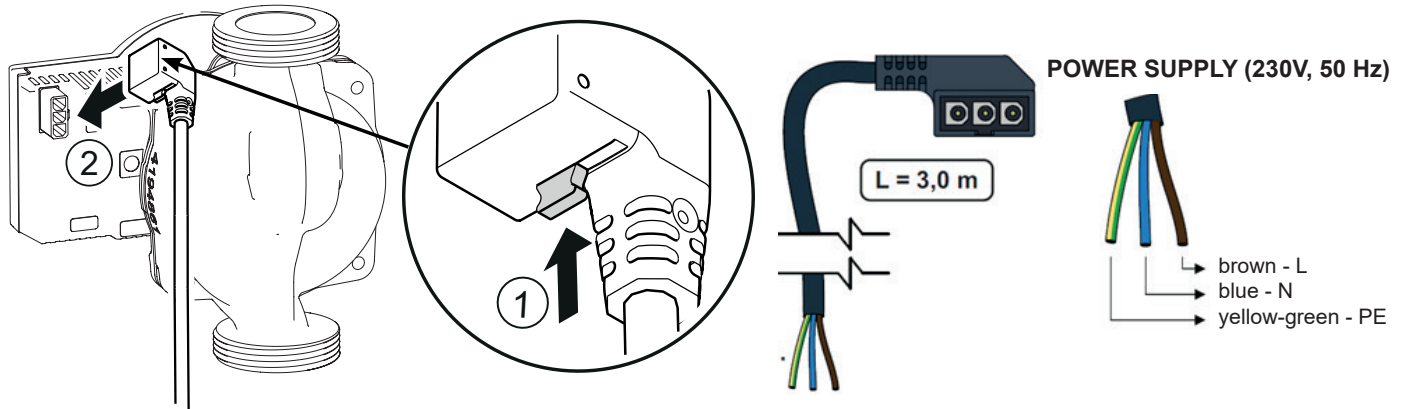

1 Lock

2 Power cable connector

## 5.5. Pump Control

Constant speed operating mode and pump performance curve III are preset as factory settings for the PARA SC pump. After switching on, the pump runs at the factory setting or at the last setting.

The settings can be changed using the operating button, see below.

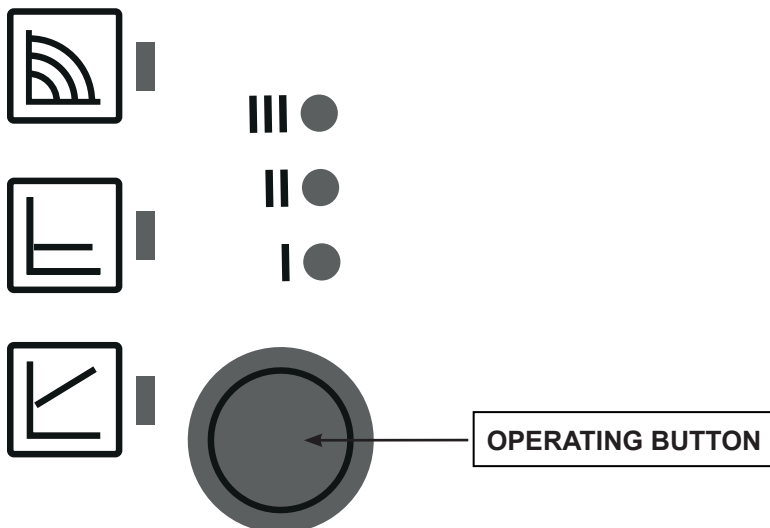

Briefly press the operating button to:

select the **pump operating mode**: constant speed,  $\Delta p-v$  or  $\Delta p-c$  and the pump **performance curve** (I, II, III)

## Press and hold the operating button for the specified time to activate:

- **Pump venting function** - hold the control button for 3 seconds.
- **Manual restart** - hold the operating button for 5 seconds.
- **Locking / Unlocking the operating button** - hold the button for 8 seconds
- **Factory setting** - hold the control button for at least 4 seconds and switch off the pump by disconnecting it from the mains.

## SETTING THE PUMP PROFILE

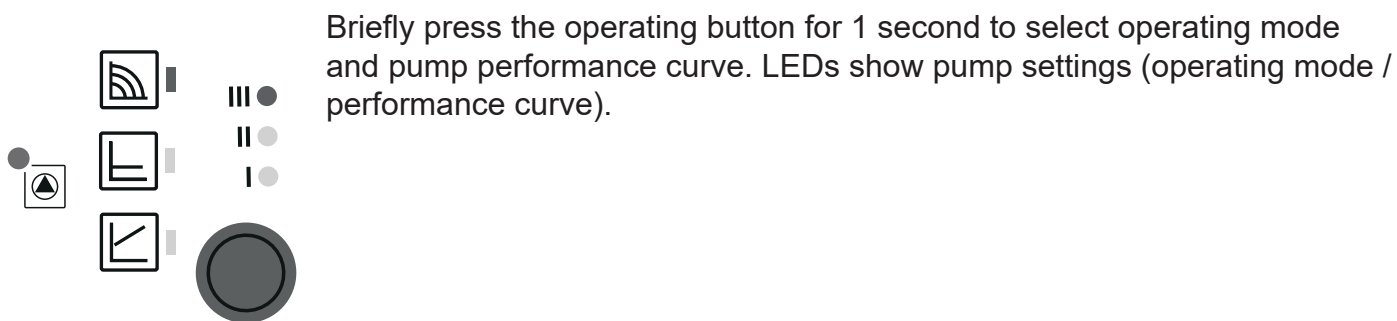

	LED indicators	Operating mode	Performance curve
1		constant speed	II
2		constant speed	I
3		$\Delta p$ -v variable	III
4		$\Delta p$ -v variable	II
5		$\Delta p$ -v variable	I
6		$\Delta p$ -c constant	III
7		$\Delta p$ -c constant	II
8		$\Delta p$ -c constant	I
9		constant speed	III



## PUMP VENTING

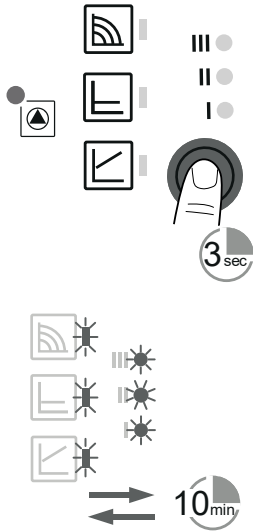

### If air is present in the pump:

- o Activate the pump venting function by pressing and holding the operating button for 3 sec. The upper and lower rows of LEDs will flash in 1sec interval, see Fig.
- o Pump venting takes 10 minutes, after that the pump returns to current mode. In order to cancel pump venting, press and hold the operating button for 3 sec.

## MANUAL RESTART



If the pump has been inactive for a long time or is blocked, activate the manual restart by holding the operating button for 5 seconds. The LEDs flash sequentially clockwise. The manual restart takes max. 10 minutes before the pump returns to normal operation. To cancel the manual restart, hold down the operating button for 5 seconds.

If the pump does not get unblocked, contact a qualified technician.

## OPERATING BUTTON LOCKING / UNLOCKING

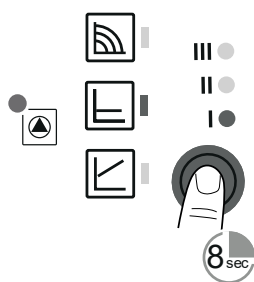

To lock the operating button, press it for 8 seconds.

The selected setting then starts flashing and cannot be changed. To unlock, hold down the operating button again for 8 seconds and the LEDs will stop flashing.



## FACTORY SETTINGS

To return to the factory settings, press and hold the operating button for at least 4 sec. (all LEDs flash for 1 second) and turn off the pump by unplugging. When switched on again, the pump will run at the factory settings.

# PUMP OPERATING MODES

## Variable differential pressure $\Delta p-v$

**It is not recommended to use variable differential pressure for solid fuel boiler pumps!**

The Variable differential pressure operating mode is recommended in systems where it is advisable to reduce the discharge pressure of the pump in parallel with the decreasing required flow rate. A typical example is a heating circuit with radiators equipped with thermostatic valves, where the selection of this operating mode can reduce the noise from thermostatic valves which is caused by closing too many radiators in the system. This mode, on the other hand, is unsuitable for circuits with heat sources where the reduction of the head and flow can make these sources even inoperable.

By reducing the discharge as the flow decreases, the pump's power consumption and therefore the operating costs are significantly reduced (see graph Q-P). In larger heating circuits and in circuits where there are significant differences in heating demand in separate heating zones, this mode may temporarily cause insufficient heating. In these systems, it may be preferable to switch the pump to  $\Delta p-c$  mode.

### Performance curves

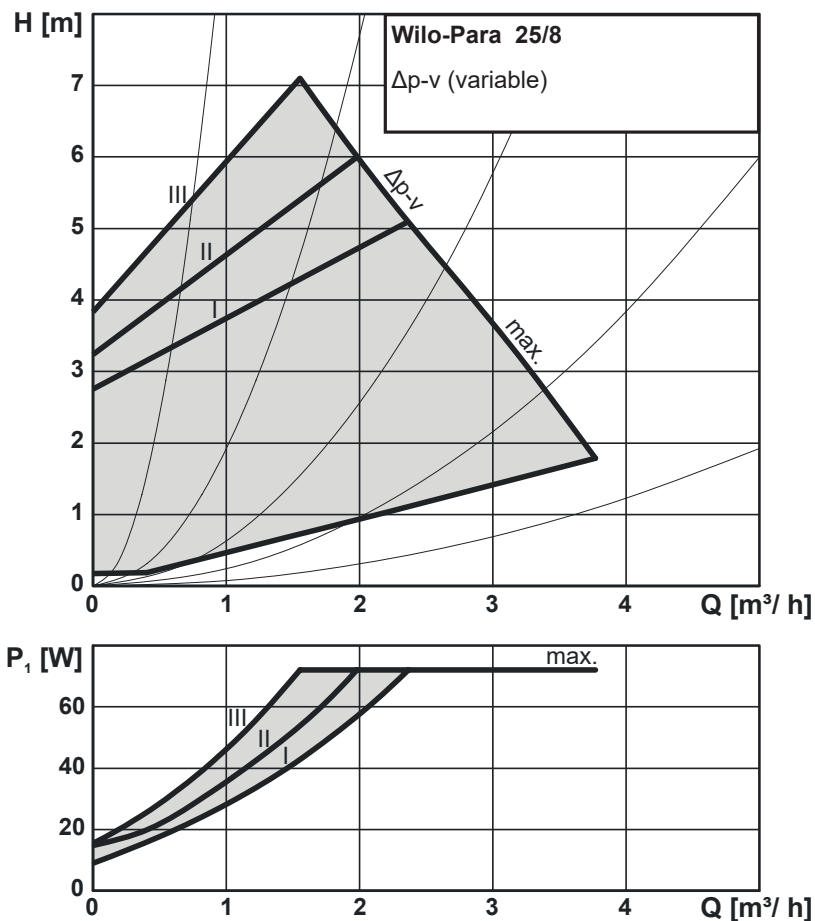

## Constant differential pressure $\Delta p$ -c

The Constant differential pressure (constant delivery head) operating mode is suitable for hydraulic circuits of heat sources (boilers, heat pumps, solar thermal systems etc.), hot water storage tanks, heaters, underfloor heating systems and large heating circuits where the previous mode  $\Delta p$ -v could cause insufficient heating through discharge reduction.

By decreasing the required flow, the pump maintains a constant delivery head, thus the pump power consumption decrease is more gentle than in the  $\Delta p$ -v mode.

### Performance curves

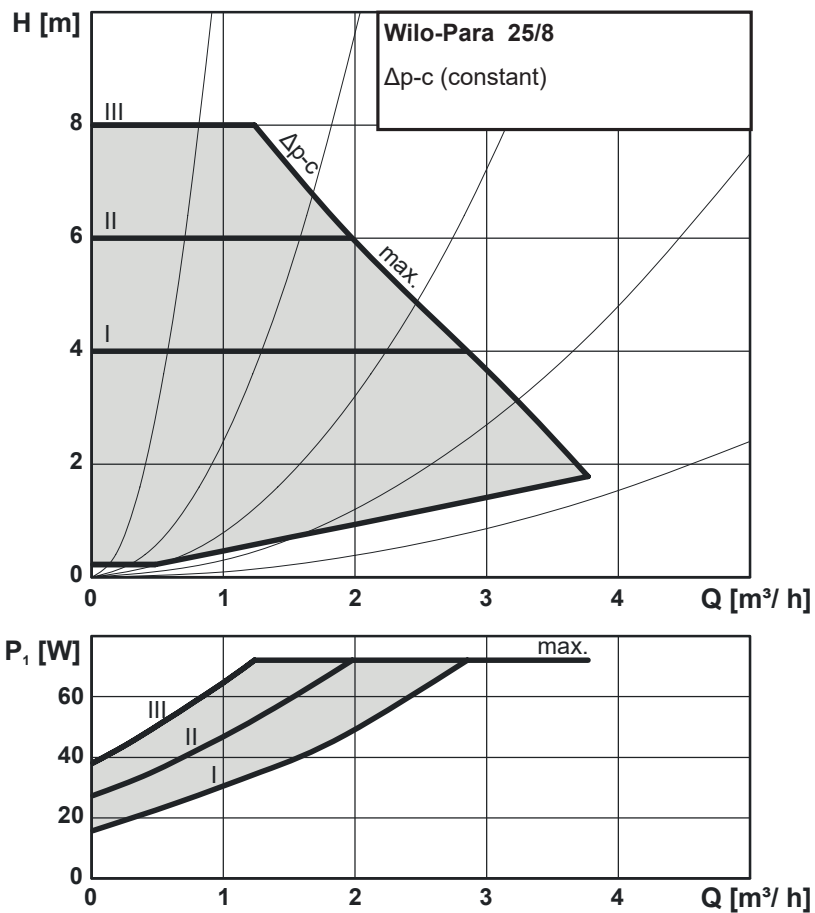



## Constant speed

Constant speed operating mode means that the pump does not adjust its speed in any way depending on the flow rate or discharge of the hydraulic circuit. The flow and discharge of the pump are thus entirely dependent on the speed setting set (I, II, III) and the hydraulic circuit settings. This mode is used when the more economical  $\Delta p$ -c mode is not suitable. This is the same mode as in the older types of classic circulation pumps where the speed I, II, III was set by a selector switch.

For example, this mode may be suitable for older circuit types where flow is regulated by throttling and this method required to be maintained. Furthermore, it may be suitable for solid fuel boilers that are equipped with older types of TSV valves with balancing using a manual throttle valve, or in other similar specific cases of requiring a constant pump performance.

### Performance curves

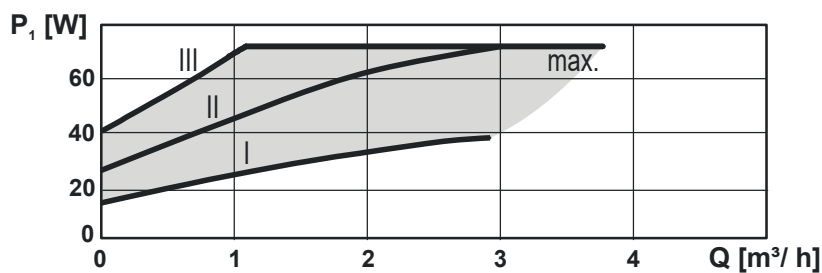
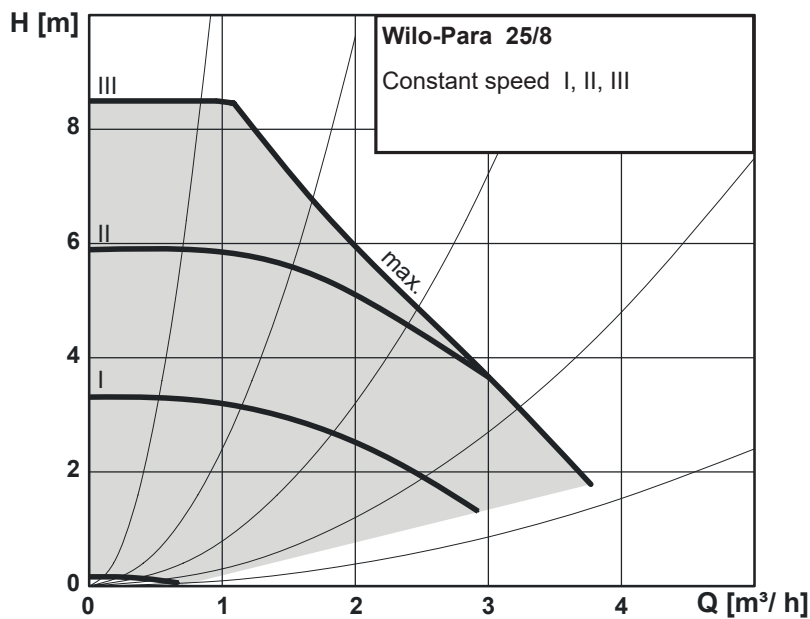





## 5.6. Technical Data

<b>Wilo PARA 25/8 SC</b>	
<b>Electric Data</b>	
Power supply	230 V, 50 Hz
Power input (min./max.)	2 / 75 W
Current (min./max.)	0.03 / 0.66 A
Max. speed	4800 rpm
Speed control	frequency converter
Energy Efficiency Index	≤ 0.21 by EN 16 297/3
IP rating	IPX4D
Motor protection	integrated
<b>Operating data</b>	
Max. head	8.4 m

## 5.7. FAULTS, THEIR REASONS AND TROUBLESHOOTING

 The LED light signals a defect. The pump will switch off (depending on the defect type) and try to restart.

LED indication		state description and possible fault reasons
	green is lit	1 - pump is running in trouble-free operation
	red is lit	1 - rotor is blocked 2 - electric motor winding defect
	flashing red	1 - power supply lower/higher than 230 V 2 - electric short circuit in pump 3 - pump overheated
	flashing red and green	1 - unforced fluid circulation through the pump 2 - pump speed lower than desired 3 - air in pump

FAULTS	REASONS	TROUBLESHOOTING
Pump does not run despite power supply switched on	Pump not energized	Check circuit breakers or fuses in the system control
Pump is making noise	Cavitation due to insufficient inlet pressure	Increase pressure in heating system within permissible range or check that circuit breaker has not tripped Check head setting, if necessary, set lower head
Building not warming up	Heat output of heating surfaces too low	Set higher temperature at controller and fully open radiator valves. If this does not help, increase circulation pump performance.

If the fault cannot be rectified, contact a specialized technician.

## 6. Installation options

This Load Unit comes in the version for horizontal installation to the right of a boiler. However, it can be installed also into vertical piping or horizontally to the left of a boiler. When being installed horizontally to the left of a boiler, the Load Unit needs to be turned by 180° and the TSV5 valve turned as shown in the pics below.

