



Installation and Operation Manual **EN**
CSE SOL W SRS1 T SOLAR PUMP STATION, 2-20 l/min
w. electronic control & flow rate measurement

1. Introduction

CSE SOL W SRS1 T Solar Pump Station is fitted with a solar pump of the latest generation that permits smooth flow control through PWM signal and sends information on the actual flow rate to the controller that shows the value on its display. The complicated setting of the right flow rate is not needed, the Pump Station keeps adjusting it automatically, depending on the actual solar radiation. This means that the solar thermal system always works with the maximum possible efficiency.

2. Main features

Main features	
Application	<p>The Solar Pump Station contains all components necessary for current and efficient operation of a solar thermal system.</p> <p>An electric heating element of up to 3 kW output, or a gas boiler, or another switched heat source can be connected to the pump station. Switching the heat source on and off is controlled by the controller. The heat source must be connected to the potential-free contact of the controller.</p> <p>No heating element is included in supply.</p>
Description	<p>The pump station consists of a Para ST 25/7-50/iPWM2 pump, SRS1 T controller, non-return and safety valves, 2 ball valves, a pressure gauge, thermometer, insulation and an assembly kit.</p> <p>The pump station further involves:</p> <ul style="list-style-type: none"> ● connection point for an expansion vessel ● safety valve outlet, incl. extension piping terminating under the pump station for easier connection ● ball valves for filling, draining and topping up a solar thermal system ● connected temperature sensors for solar consumer (4m cable) ● solar temperature sensor (2m cable, silicone insulation) ● 230V power cable w. el. plug (3m cable, PVC insulation)
Flow measurement	The pump sends electronic information on the flow rate to the controller which then shows the indicative value on its display.
Installation	Tank-mount or wall-mount.
Working fluid	Water-glycol mixture (max. 1:1)

Codes in relation to a connection size					
Connection	G 3/4" M	G 1" M	Cu 22 mm	Cu 28 mm	Cu 18 mm
Code	17726	17902	17903	17904	18117

3. Data for the Pump Station and Accessories

Data for CSE SOL W SRS1 T Pump Station	
Max. fluid working temperature	110 °C
Max. working pressure	6 bar
Min. system pressure	1.3 bar with the pump stopped
Flow rate measurement range*	2 - 20 l/min
Heat source switching	potential-free contact (max. 3 kW)
Max. switched current	13 A / 230 V
Power supply	230 V, 50 Hz
IP rating	IP20
Ambient temperature	5 - 40 °C
Max. rel. humidity	85 % at 25 °C
Overall dimensions	470 x 265 x 120 mm
Total weight	7.0 kg

* the pump station may be used also for systems with a higher flow rate than 20 l/min, then the controller will show the flow rate value as > 20 l/min.

Min. working pressure values**	
Min. working pressure values at the suction port depending on temperature	0.8 bar at 50 °C 1.2 bar at 90 °C 1.8 bar at 110 °C

** for standard installations this condition is met when the initial system pressure is set following the formula (see the collector guide): $p = 1,3 + 0,1 \cdot h$ [bar], where h ... height from the pressure gauge to the middle of the collector array [m]

Pump Station internal wiring

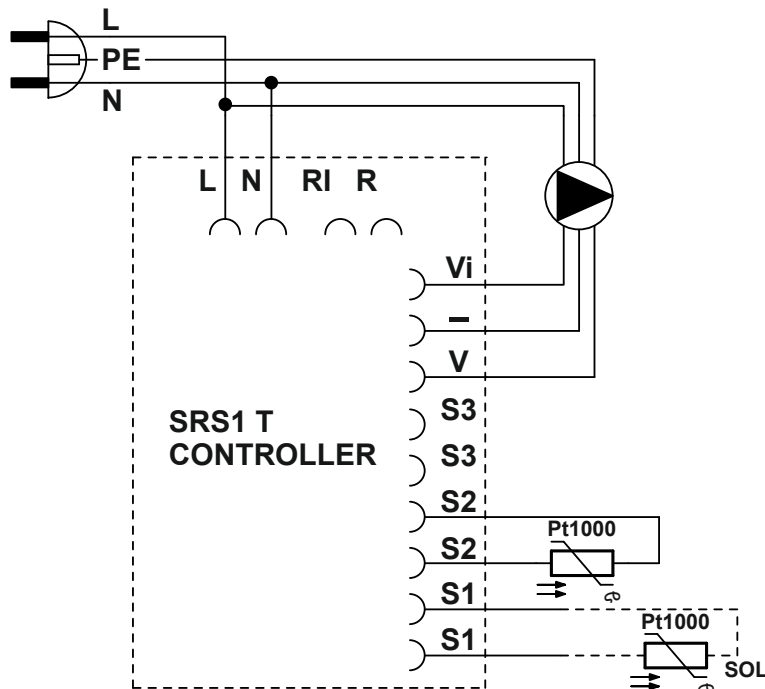

- L live
- N neutral
- RI, R potential-free switching contact
- Vi iPWM feedback signal
- GND PWM
- V PWM control signal output
- S2 sensor 2 (solar consumer)
- S1 sensor 1 (collector)

Sensor S3 not included. When installing a solar pump station in cases where sensor S3 is required, it shall be ordered as an accessory (see page 5) and connected according to the SRS1 T controller instructions.

Temperature Resistance Table for Pt1000 Sensors

°C	0	10	20	30	40	50	60	70	80	90	100
Ω	1000	1039	1077	1116	1155	1194	1232	1270	1308	1347	1385

3.1 Pump Station Pressure Drop Graph

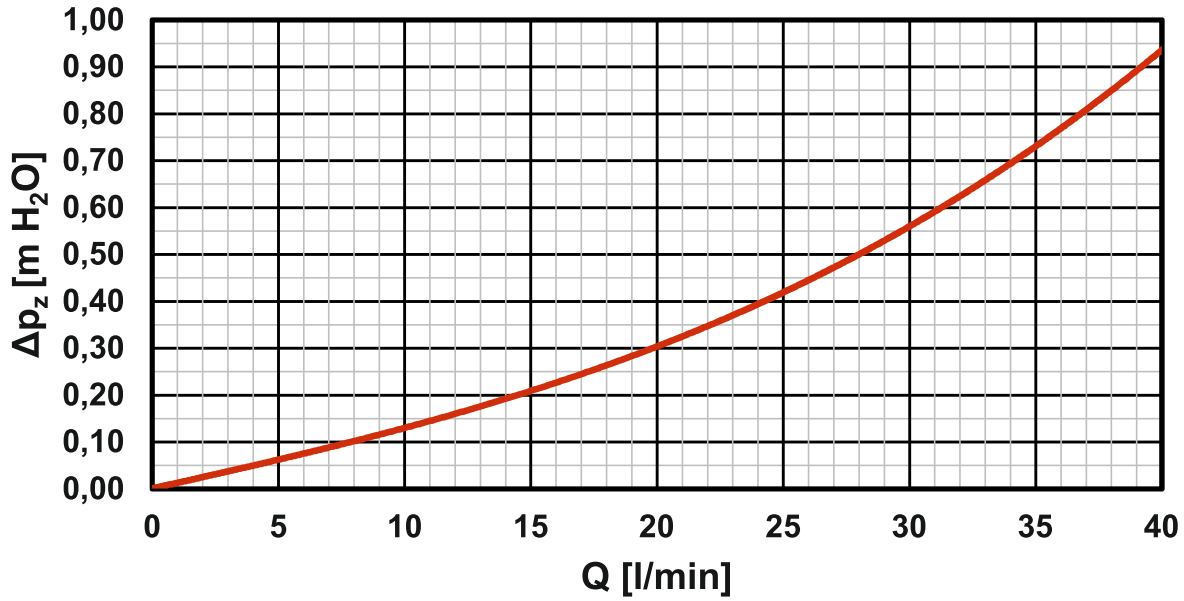

4. Pump Station Components

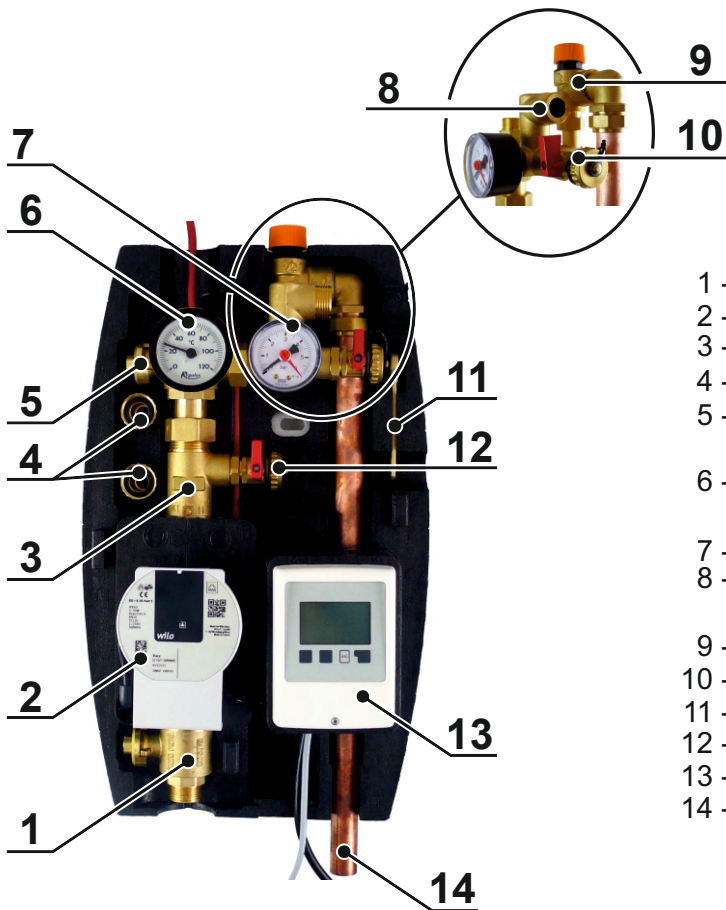

- 1 - BALL VALVE
- 2 - SOLAR CIRCULATION PUMP
- 3 - NON-RETURN VALVE
- 4 - FILL/DRAIN HOSE SOCKET
- 5 - BALL VALVE WITH T-BRANCHE FOR SAFETY ASSY
- 6 - THERMOMETER (IN INSULATION UPPER PART)
- 7 - PRESSURE GAUGE
- 8 - EXPANSION VESSEL CONNECTION POINT, 3/4" M
- 9 - 6 BAR SAFETY VALVE
- 10 - FILLING BALL VALVE
- 11 - SPANNER FOR BALL VALVES
- 12 - DRAIN BALL VALVE
- 13 - SRS1 T ELECTRONIC CONTROLLER
- 14 - SAFETY VALVE DISCHARGE PIPE, 22 mm diam.

4.1 Non-return Valve

The non-return valve prevents the tank from being cooled down by gravity circulation during periods of no sunshine. It is located between the ball valves so it can be removed and cleaned without the need to drain solar fluid from the entire solar circuit.

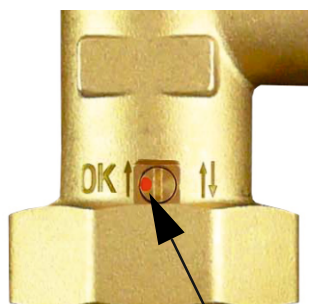

When the red mark is on the left-hand side, the non-return valve is set to normal operation position. If you need to open the valve (e.g. to drain the system), rotate its control so that the red dot is on the right-hand side. The non-return function is thus out of operation.

- ! It is important for proper operation of the pump station under normal use to have the non-return valve control always in the right position, i.e. the red mark on the left-hand side (see fig.).

The right position during operation.

4.2 Ball Valves

Ball valves are intended to isolate the pump station from a solar circuit. Then it is not necessary to drain the solar circuit for servicing (incl. cleaning the non-return valve). In order to have a more solid hydraulic section of the pump station, the upper ball valve is fixed to the rear mounting plate.

The ball valves are controlled by a lever that is not present on the valve during operation. The valve is closed by turning the lever clockwise by 90°, and opened by turning it anti-clockwise. Prior to turning the lever, the upper part of the insulation needs to be removed. Thanks to that, shutting off the solar circuit is reserved to installers and servicing staff. The user cannot simply shut off the solar circuit, bringing about stagnation and subsequent solar fluid degradation.

The ball valves are fitted with a gland with 2 O-rings (8.7x1.8 mm) that can be easily replaced after the control element with stops is removed and the gland nut released using a #21 spanner.

WARNING! IMPORTANT!

The safety relief valve, expansion vessel and upper filling valve always remain connected with the solar thermal system, even when the ball valves are shut off! Never try to isolate them from a filled solar thermal system as there is a risk of serious injury and damage to the system!

Never close the safety valve discharge piping, it shall remain free for fluid eventually discharged by the safety valve!

5. Accessories

Accessories (not included in supply)	code
Straight Pipe Fitting, Cu 22 x Cu 22	7629
Straight Pipe Fitting, Cu 22 x G 3/4" M	13695
Pt1000 temperature sensor with 4m cable (sensor S3)	9109

These accessories are not included in supply. The pipe fittings (7629 and 13695) are intended for connecting a waste pipe to the safety valve. The Pt1000 temperature sensor (9109) is needed when the pump station is to be used following the hydraulic variants 1, 2 and 3 (see chapter 7.3).

6. Installation Options

The solar pump station is designed to be installed on a wall or on a tank. There are two installation openings in the insulation rear part. The lower one is accessible only after the electronic controller is removed from the insulation rear part (see fig.).

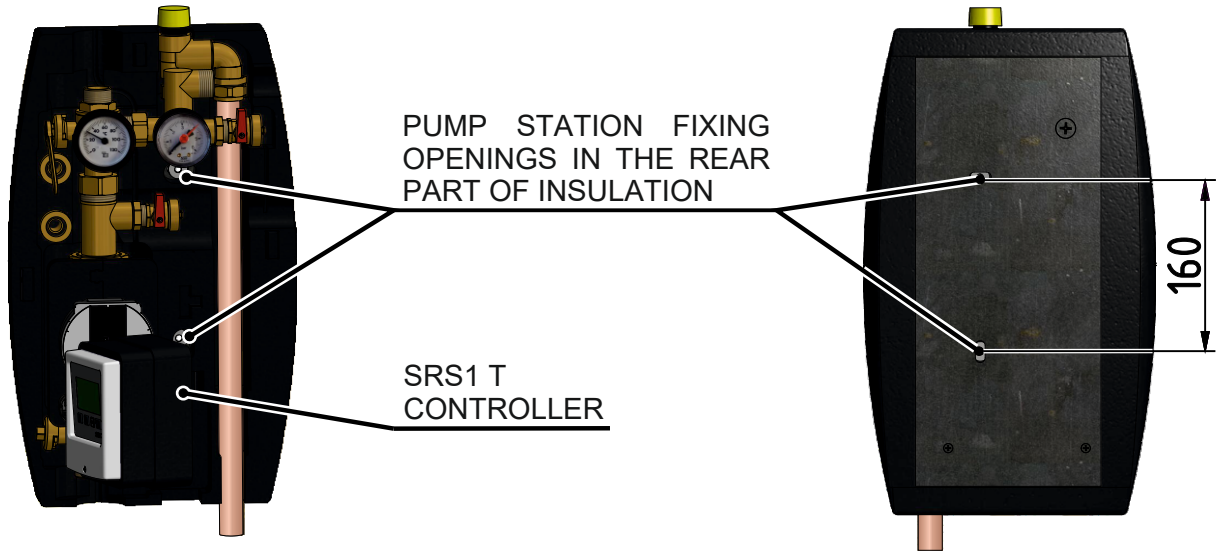

The supply involves an installation kit that is used to fix the pump station in its place.

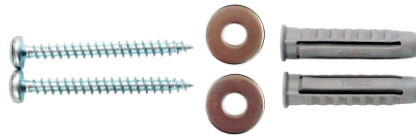

7. Pump Station Connection Diagrams

7.1 Variant with an electric heating element

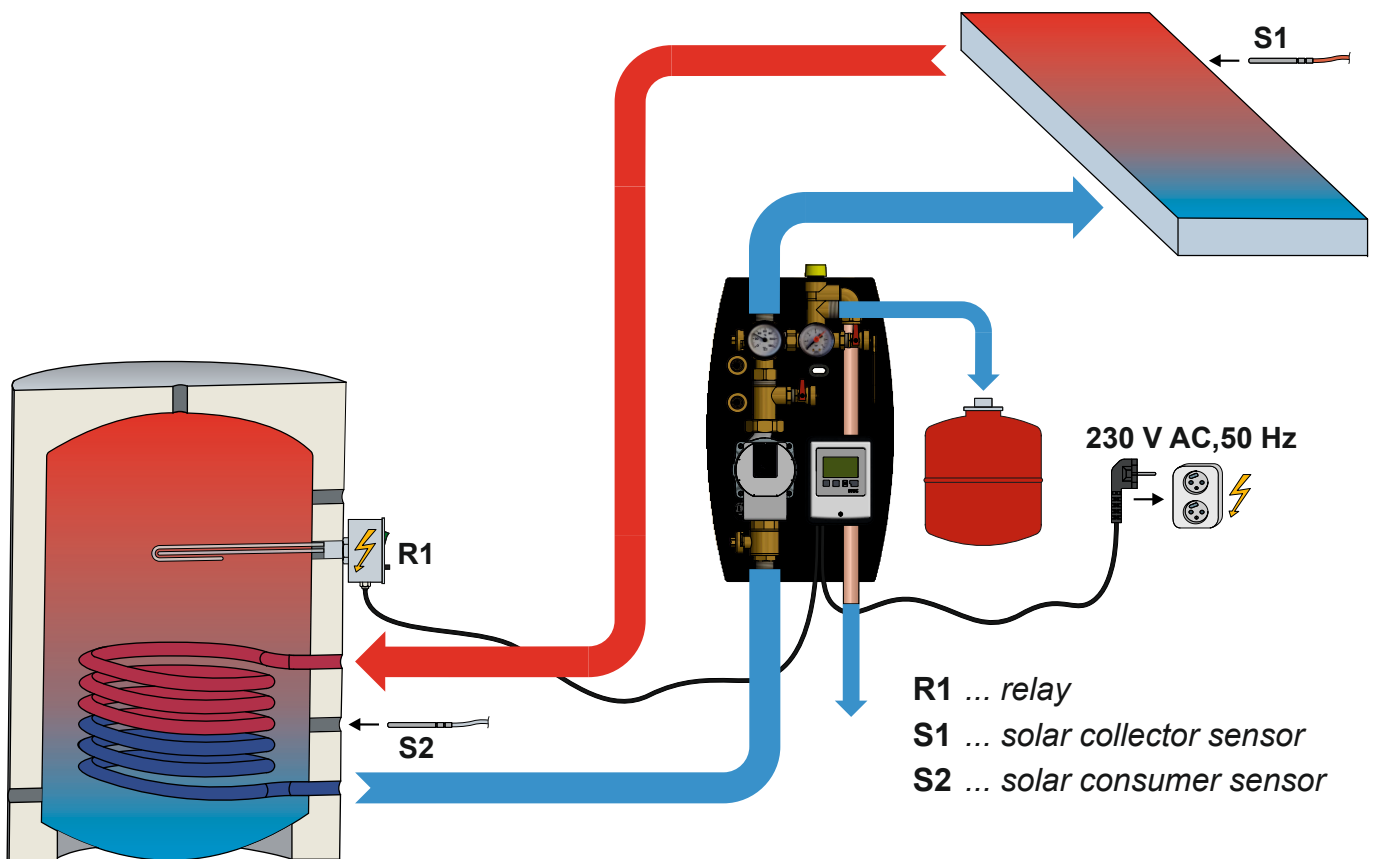

7.2 Variant with a gas boiler

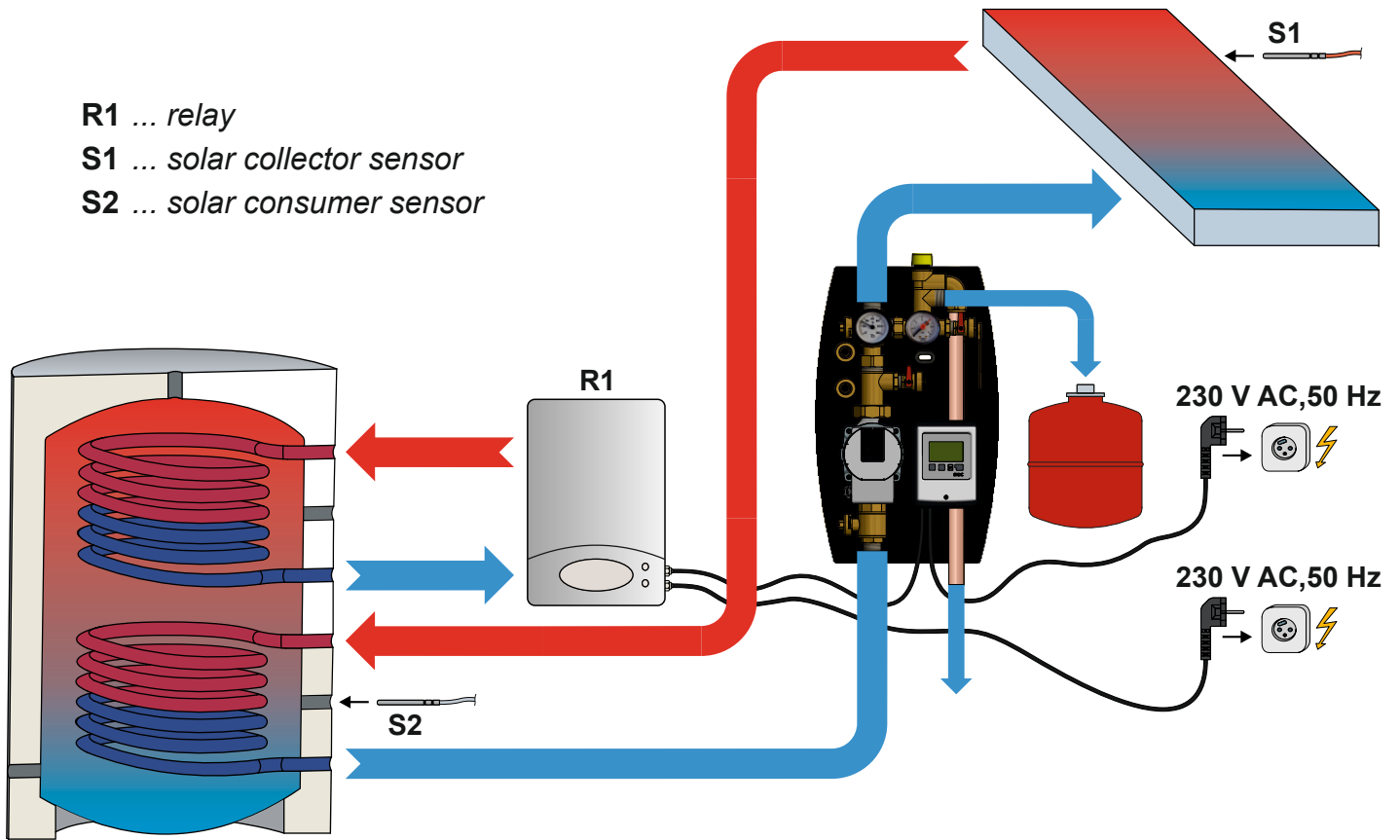



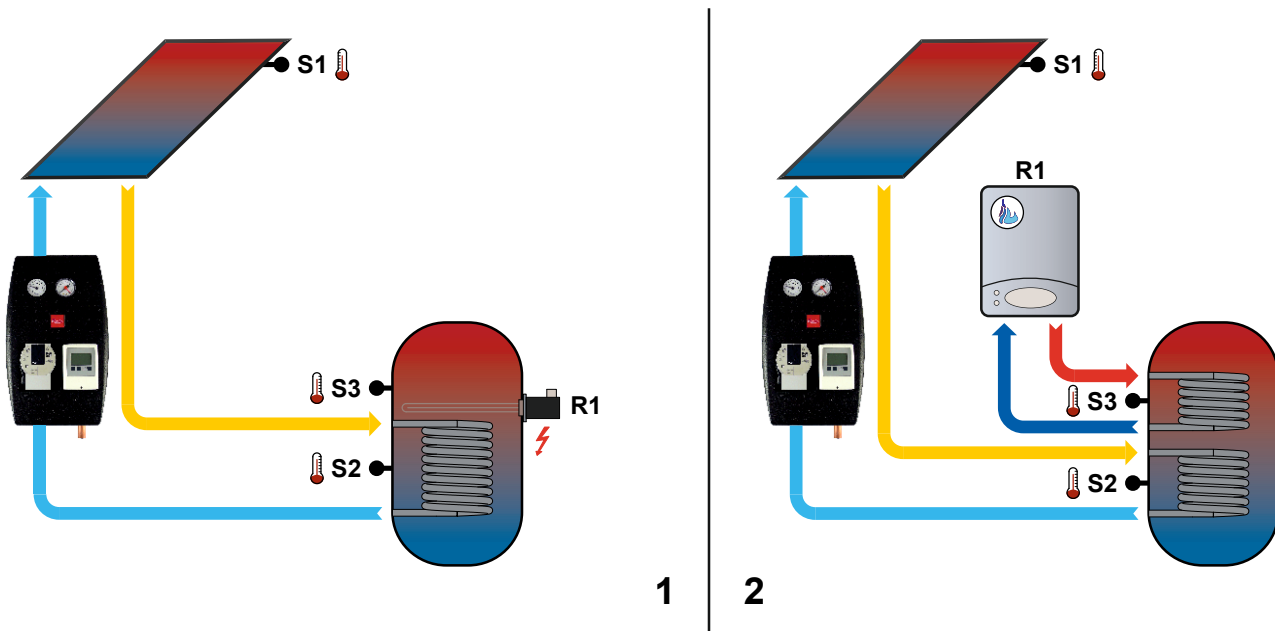

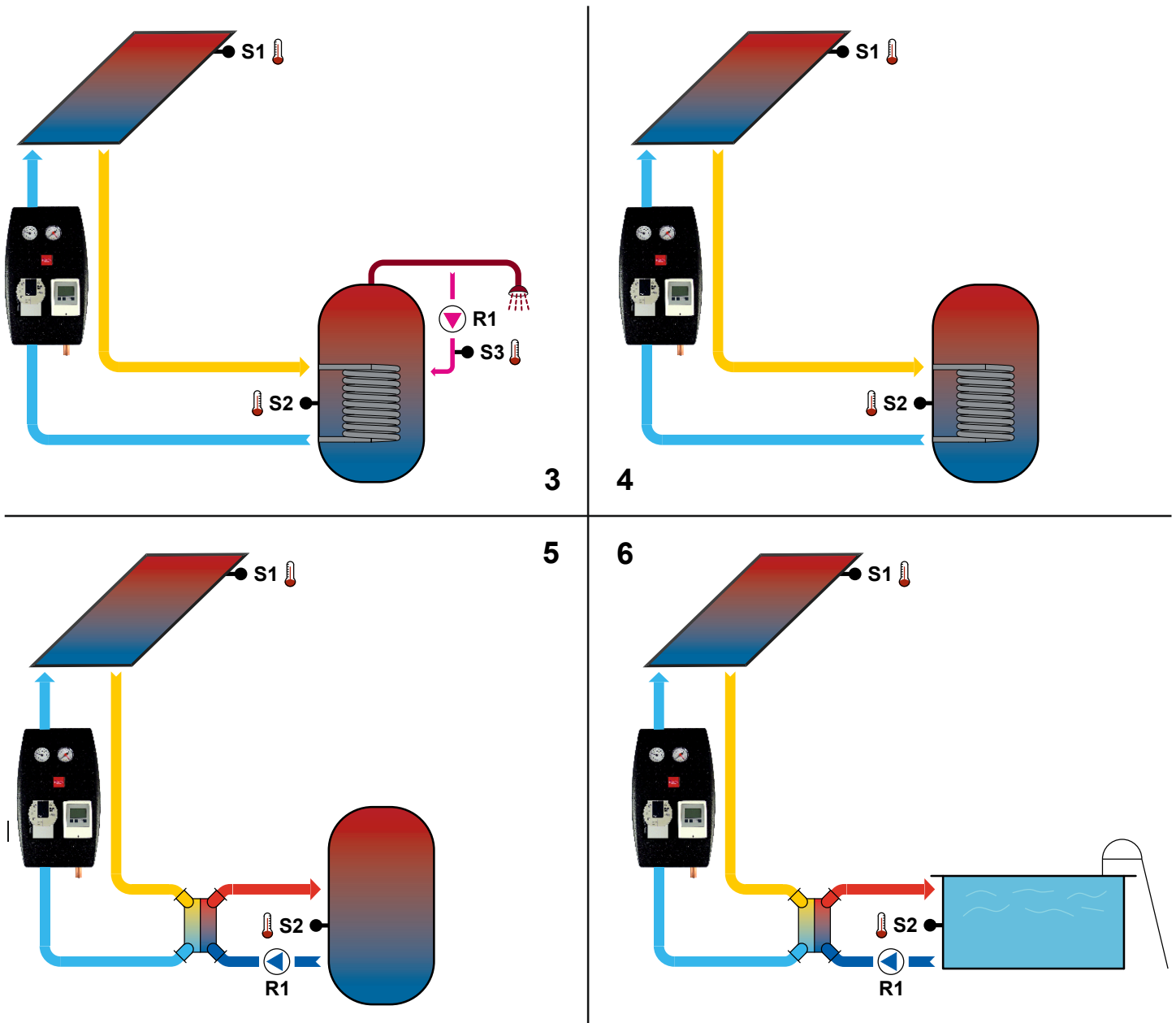
7.3 Hydraulic Variants





8. Graphic Operation Signals and Performance Curves of the Pump

8.1 Pump Operation Graphic Signals

LED SIGNALS	STATE DESCRIPTION AND POSSIBLE FAULT REASONS
 GREEN IS LIT	1) pump is running in trouble-free operation
 RED IS LIT	1) rotor is blocked 2) electric motor winding defect
 BLINKING RED	1) power supply lower/higher than 230 V 2) electric short circuit in pump 3) pump overheated
 BLINKING RED AND GREEN	1) unforced fluid circulation through the pump 2) pump speed lower than desired 3) air in pump

8.2 Performance Curves for Para ST 25/7-50/iPWM2 Pump

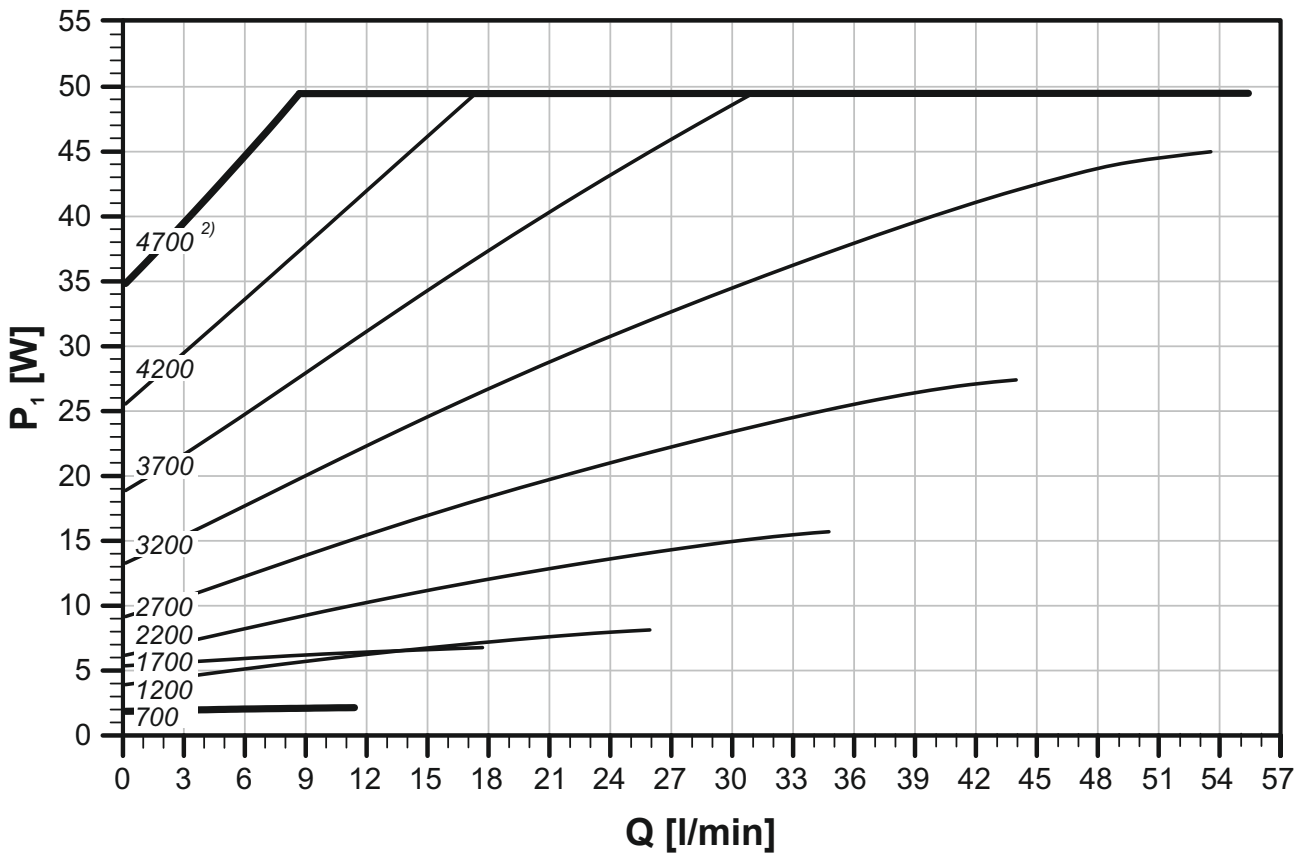
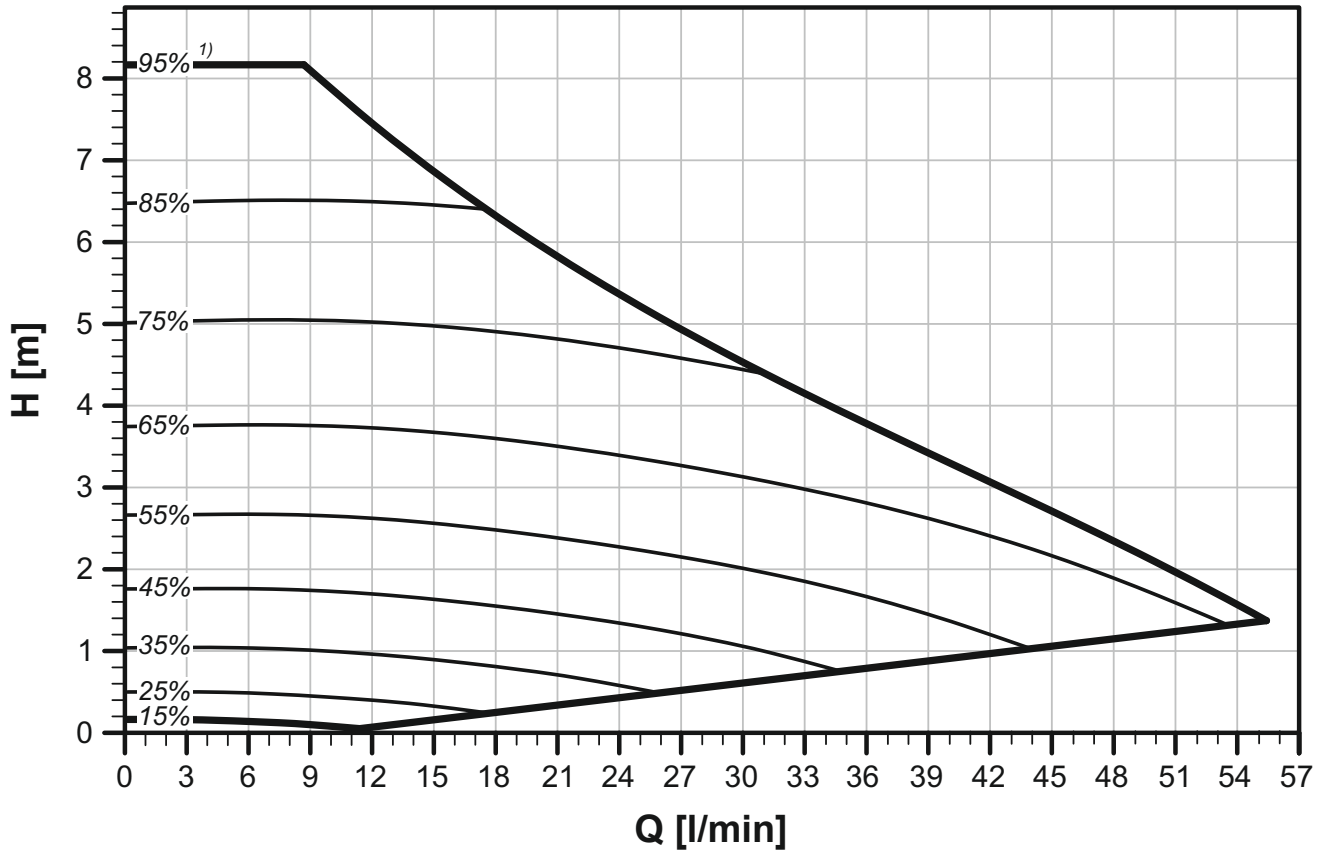

NOTE: 1) value of PWM signal in % 2) speed in rpm

9. Filling a Solar Thermal System

For filling a solar thermal system, the ball valve above the pump must be closed and the ball valve below the pump open. The open/closed position is indicated by a groove on the ball valve. If the groove is pointing horizontally, the ball valve is closed; if it is pointing vertically, the ball valve is open. See the fig. below (the groove position is marked in red).

The ball valves are operated by means of a lever handle. During normal operation, both are in the open position. To fill the solar thermal system, close the ball valve above the pump by turning the lever handle clockwise by a quarter turn. After filling the solar thermal system, turn the lever handle counter-clockwise to re-open the valve.

Prior to commissioning the system, both the ball valves must be open!

