



Installation and Operation Manual
DUO Thermal Store with Immersed DHW Tank
DUO 390/130 N PR, DUO 600/200 N PR, DUO 750/200 N PR,
DUO 1000/200 N PR, DUO 1700/200 N PR

CONTENTS

1 Description	3
1.1 Models	3
1.2 Tank protection	3
1.3 Thermal insulation	3
1.4 Packaging	3
2 General Information	3
3 Technical Data and Dimensions	4
4 Operation	9
5 Typical Layout Example with Thermal Store	9
6 Installation and Commissioning	10
6.1 Connection to heat sources	10
6.2 Connection to a solar thermal system	10
6.3 Heating element installation	10
6.4 Connection to water mains	10
6.5 Commissioning	10
7 Installing Insulation on the Tank	11
8 Maintenance	12
9 Disposal	12
10 Warranty	12

1 - Description

DUO N Thermal Stores are intended for storing and subsequent distribution of thermal energy from various heat sources like solid-fuel boilers, heat pumps, electric boilers etc. A DHW tank is integrated inside the thermal store. For a better thermal layering, the tank volume is separated by a metal plate. The lower section is equipped with a solar heat exchanger. The thermal store shall be connected to a sealed heating system with forced circulation.

For proper operation of a tank, it is necessary to have an optimum hydraulic design of the entire heating system, i.e. position of circulation pumps for both heat sources and heating circuits, valves, non-return valves etc. When more heat sources shall be combined, it is recommended to use a smart controller for both the heat source and heat consumer sections of a heating circuit, i.e. also for charging and discharging a thermal store.

1.1 - Models

Models DUO 390/130 N PR, DUO 600/200 N PR, DUO 750/200 N PR, DUO 1000/200 N PR and DUO 1700/200 N PR permitting installation of electric heating elements and other external heat sources.

1.2 - Tank protection

The inner DHW tank is made of stainless steel. A chain-type magnesium anode is installed in it for an increased level of protection. The thermal store has no inner surface finish, the outer surface is lacquered.

1.3 - Thermal insulation

Thermal insulation is available as a separate item. For easier handling, the insulation shall not be fitted on the tank until it reaches its definite place of installation. The insulation is made of fleece, 100 mm thick, with a hard polystyrene surface. It is closed by quick locks.

1.4 - Packaging

Tanks are delivered standing, each screwed to its pallet, packed in bubble wrap. The tank is then shrink-wrapped together with its pallet.

It is forbidden to transport and/or store the storage tanks in a horizontal position.

2 - General Information

This Owners Manual is an integral and important part of the product and must be handed over to the User. Read carefully the instructions in this Manual as they contain important information concerning safety, installation, operation and maintenance. Keep this Manual for later reference. The appliance shall be installed by qualified staff according to valid rules and Manufacturer's Instructions.

This appliance is designed to accumulate heating water and distribute it subsequently. It shall be connected to a heating system and heat sources. This appliance is also suitable for accumulator heating of domestic hot water.

Using the Thermal Store for other purposes than above described is forbidden and the manufacturer accepts no responsibility for damage caused by improper or wrong use or filling procedure.

Before filling the thermal store, fill and pressurize the inner DHW tank first!!!

3 - Technical Data and Dimensions

Regulus DUO N PR

Regulus DUO 390/130 N PR Thermal Store (code:19139, insulation - code: 19293)

Dimensions		CONNECTIONS																																																																																																																																													
<p>Tipping height without insulation 1950 mm</p>		<table border="1"> <thead> <tr> <th>pos.</th> <th>descriptions</th> <th>connection</th> <th>height [mm]</th> </tr> </thead> <tbody> <tr> <td colspan="4">Heat sources</td> </tr> <tr> <td>B1</td> <td>Incoming from heat source</td> <td>G 1" F</td> <td>780</td> </tr> <tr> <td>B2</td> <td>Return to heat source</td> <td>G 1" F</td> <td>130</td> </tr> <tr> <td>B3</td> <td>Incoming from heat source</td> <td>G 1" F</td> <td>1630</td> </tr> <tr> <td>B4</td> <td>Return to heat source</td> <td>G 1" F</td> <td>880</td> </tr> <tr> <td>B5</td> <td>Incoming from heat source</td> <td>G 1" F</td> <td>1540</td> </tr> <tr> <td colspan="4">Heating system</td> </tr> <tr> <td>H1</td> <td>Outlet to the heating circuit</td> <td>G 1" F</td> <td>780</td> </tr> <tr> <td>H2</td> <td>Return from the heating circuit</td> <td>G 1" F</td> <td>210</td> </tr> <tr> <td colspan="4">Solar system</td> </tr> <tr> <td>X1</td> <td>Incoming from solar collectors</td> <td>G 1" F</td> <td>660</td> </tr> <tr> <td>X2</td> <td>Return to solar collectors</td> <td>G 1" F</td> <td>210</td> </tr> <tr> <td colspan="4">Electric heating elements</td> </tr> <tr> <td>E1</td> <td>Electric heating element for space heating</td> <td>G 6/4" F</td> <td>720</td> </tr> <tr> <td>E2</td> <td>Electric heating element for space heating</td> <td>G 6/4" F</td> <td>720</td> </tr> <tr> <td>E3</td> <td>Electric heating element for DHW heating</td> <td>G 6/4" F</td> <td>980</td> </tr> <tr> <td colspan="4">DHW heating</td> </tr> <tr> <td>W1</td> <td>Cold water</td> <td>G 3/4" M</td> <td>1910</td> </tr> <tr> <td>W2</td> <td>Hot water</td> <td>G 3/4" M</td> <td>1910</td> </tr> <tr> <td>W3</td> <td>Recirculation</td> <td>G 3/4" M</td> <td>1910</td> </tr> <tr> <td>A1</td> <td>Anode</td> <td>G 3/4" F</td> <td>1855</td> </tr> <tr> <td colspan="4">Control and safety</td> </tr> <tr> <td>C1</td> <td>Temperature sensor – space heating</td> <td>G 1/2" F</td> <td>750</td> </tr> <tr> <td>C2</td> <td>Temperature sensor – solar</td> <td>G 1/2" F</td> <td>510</td> </tr> <tr> <td>C3</td> <td>Temperature sensor – DHW heating</td> <td>G 1/2" F</td> <td>1160</td> </tr> <tr> <td>C4</td> <td>Temperature sensor – DHW heating</td> <td>G 1/2" F</td> <td>1020</td> </tr> <tr> <td>T</td> <td>Thermometer</td> <td>G 1/2" F</td> <td>1630</td> </tr> <tr> <td>M</td> <td>Pressure gauge</td> <td>G 1/2" F</td> <td>510</td> </tr> <tr> <td>P</td> <td>Safety valve</td> <td>G 1/2" F</td> <td>400</td> </tr> <tr> <td colspan="4">Air release</td> </tr> <tr> <td>O</td> <td>Air vent valve</td> <td>G 1/2" F</td> <td>1885</td> </tr> <tr> <td colspan="4">Other</td> </tr> <tr> <td>F1</td> <td>Attaching the pump station</td> <td>M 6</td> <td>1430</td> </tr> <tr> <td>F2</td> <td>Attaching the pump station</td> <td>M 6</td> <td>1270</td> </tr> </tbody> </table>		pos.	descriptions	connection	height [mm]	Heat sources				B1	Incoming from heat source	G 1" F	780	B2	Return to heat source	G 1" F	130	B3	Incoming from heat source	G 1" F	1630	B4	Return to heat source	G 1" F	880	B5	Incoming from heat source	G 1" F	1540	Heating system				H1	Outlet to the heating circuit	G 1" F	780	H2	Return from the heating circuit	G 1" F	210	Solar system				X1	Incoming from solar collectors	G 1" F	660	X2	Return to solar collectors	G 1" F	210	Electric heating elements				E1	Electric heating element for space heating	G 6/4" F	720	E2	Electric heating element for space heating	G 6/4" F	720	E3	Electric heating element for DHW heating	G 6/4" F	980	DHW heating				W1	Cold water	G 3/4" M	1910	W2	Hot water	G 3/4" M	1910	W3	Recirculation	G 3/4" M	1910	A1	Anode	G 3/4" F	1855	Control and safety				C1	Temperature sensor – space heating	G 1/2" F	750	C2	Temperature sensor – solar	G 1/2" F	510	C3	Temperature sensor – DHW heating	G 1/2" F	1160	C4	Temperature sensor – DHW heating	G 1/2" F	1020	T	Thermometer	G 1/2" F	1630	M	Pressure gauge	G 1/2" F	510	P	Safety valve	G 1/2" F	400	Air release				O	Air vent valve	G 1/2" F	1885	Other				F1	Attaching the pump station	M 6	1430	F2	Attaching the pump station	M 6	1270
pos.	descriptions	connection	height [mm]																																																																																																																																												
Heat sources																																																																																																																																															
B1	Incoming from heat source	G 1" F	780																																																																																																																																												
B2	Return to heat source	G 1" F	130																																																																																																																																												
B3	Incoming from heat source	G 1" F	1630																																																																																																																																												
B4	Return to heat source	G 1" F	880																																																																																																																																												
B5	Incoming from heat source	G 1" F	1540																																																																																																																																												
Heating system																																																																																																																																															
H1	Outlet to the heating circuit	G 1" F	780																																																																																																																																												
H2	Return from the heating circuit	G 1" F	210																																																																																																																																												
Solar system																																																																																																																																															
X1	Incoming from solar collectors	G 1" F	660																																																																																																																																												
X2	Return to solar collectors	G 1" F	210																																																																																																																																												
Electric heating elements																																																																																																																																															
E1	Electric heating element for space heating	G 6/4" F	720																																																																																																																																												
E2	Electric heating element for space heating	G 6/4" F	720																																																																																																																																												
E3	Electric heating element for DHW heating	G 6/4" F	980																																																																																																																																												
DHW heating																																																																																																																																															
W1	Cold water	G 3/4" M	1910																																																																																																																																												
W2	Hot water	G 3/4" M	1910																																																																																																																																												
W3	Recirculation	G 3/4" M	1910																																																																																																																																												
A1	Anode	G 3/4" F	1855																																																																																																																																												
Control and safety																																																																																																																																															
C1	Temperature sensor – space heating	G 1/2" F	750																																																																																																																																												
C2	Temperature sensor – solar	G 1/2" F	510																																																																																																																																												
C3	Temperature sensor – DHW heating	G 1/2" F	1160																																																																																																																																												
C4	Temperature sensor – DHW heating	G 1/2" F	1020																																																																																																																																												
T	Thermometer	G 1/2" F	1630																																																																																																																																												
M	Pressure gauge	G 1/2" F	510																																																																																																																																												
P	Safety valve	G 1/2" F	400																																																																																																																																												
Air release																																																																																																																																															
O	Air vent valve	G 1/2" F	1885																																																																																																																																												
Other																																																																																																																																															
F1	Attaching the pump station	M 6	1430																																																																																																																																												
F2	Attaching the pump station	M 6	1270																																																																																																																																												

Total volume:	396l
Immersed DHW tank volume:	264 l
Fluid volume in Thermal Store:	123 l
Heat exchanger (HX) volume:	9l
Heat exchanger surface area:	1,5 sqm
Max. working temp. in thermal store:	95 °C
Max. working temperature in heat exchanger:	95 °C
Max. working temperature in DHW tank:	95 °C
Max. working pressure in DHW tank:	3 bar
Max. working pressure in thermal store:	6 bar
Max. working pressure in HX:	10 bar
Empty weight:	117 kg
Electric heating element (Accessories):	type ETT-C, F, M, P
Number and max. length of heating element:	3 x 500 mm

Regulus DUO 600/200 N PR Thermal Store (code:19133, insulation - code: 19321)

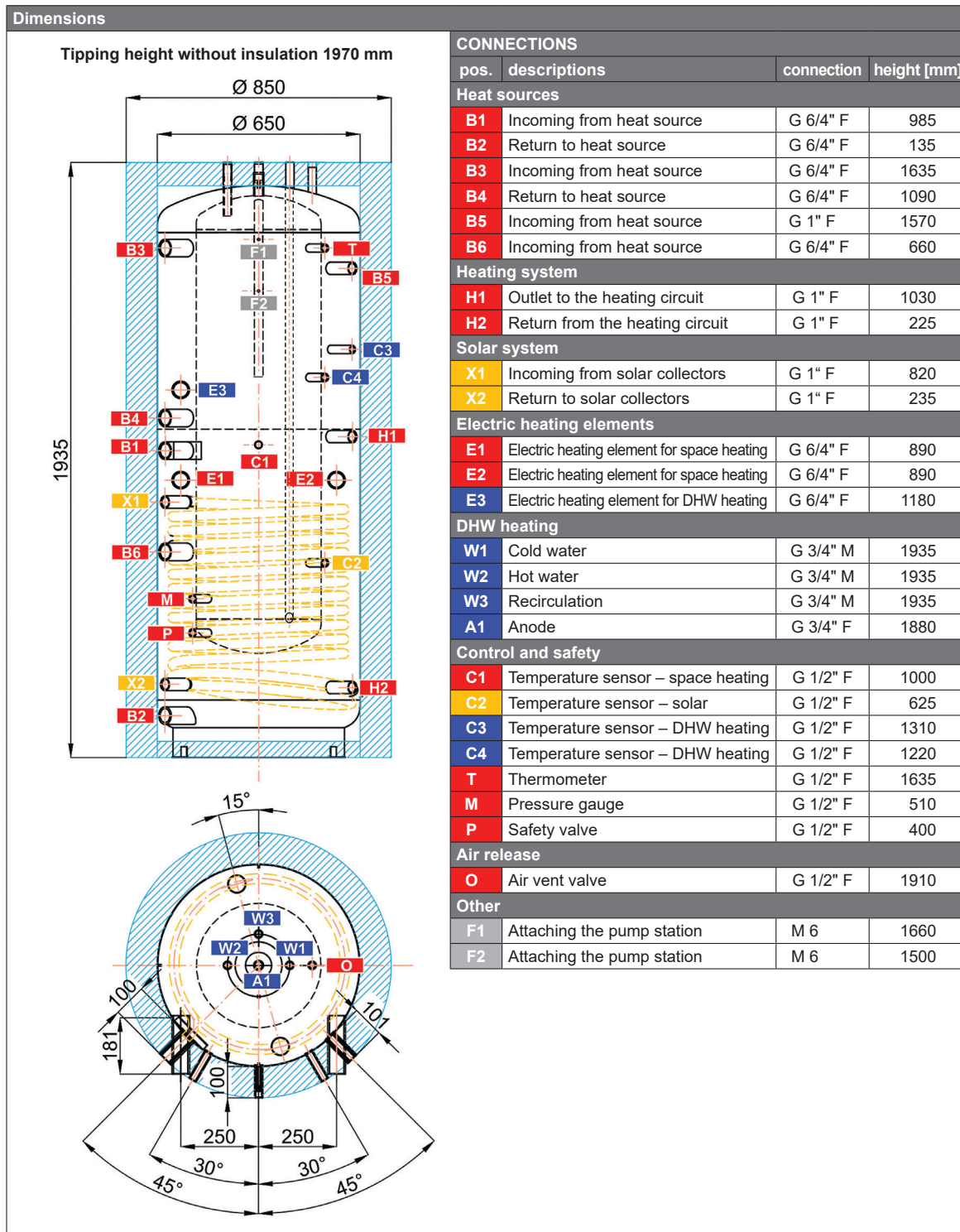

Total volume:	559
Immersed DHW tank volume:	372 l
Fluid volume in Thermal Store:	174 l
Heat exchanger (HX) volume:	13 l
Heat exchanger surface area:	2,4 sqm
Max. working temp. in thermal store:	95 °C
Max. working temperature in heat exchanger:	95 °C
Max. working temperature in DHW tank:	95 °C
Max. working pressure in DHW tank:	3 bar
Max. working pressure in thermal store:	6 bar
Max. working pressure in HX:	10 bar
Empty weight:	154 kg
Electric heating element (Accessories):	type ETT-C, F, M, P
Number and max. length of heating element:	3 x 500 mm

Regulus DUO 750/200 N PR Thermal Store (code:19135, insulation - code: 19327)

Dimensions

Tipping height without insulation 2040 mm

CONNECTIONS

pos.	descriptions	connection	height [mm]
Heat sources			
B1	Incoming from heat source	G 6/4" F	960
B2	Return to heat source	G 6/4" F	155
B3	Incoming from heat source	G 6/4" F	1655
B4	Return to heat source	G 6/4" F	1065
B5	Incoming from heat source	G 1" F	1590
B6	Incoming from heat source	G 6/4" F	635
Heating system			
H1	Outlet to the heating circuit	G 1" F	1005
H2	Return from the heating circuit	G 1" F	245
Solar system			
X1	Incoming from solar collectors	G 1" F	795
X2	Return to solar collectors	G 1" F	255
Electric heating elements			
E1	Electric heating element for space heating	G 6/4" F	865
E2	Electric heating element for space heating	G 6/4" F	865
E3	Electric heating element for DHW heating	G 6/4" F	1155
DHW heating			
W1	Cold water	G 3/4" M	1980
W2	Hot water	G 3/4" M	1980
W3	Recirculation	G 3/4" M	1980
A1	Anode	G 3/4" F	1925
Control and safety			
C1	Temperature sensor – space heating	G 1/2" F	975
C2	Temperature sensor – solar	G 1/2" F	615
C3	Temperature sensor – DHW heating	G 1/2" F	1285
C4	Temperature sensor – DHW heating	G 1/2" F	1195
T	Thermometer	G 1/2" F	1655
M	Pressure gauge	G 1/2" F	510
P	Safety valve	G 1/2" F	400
Air release			
O	Air vent valve	G 1/2" F	1955
Other			
F1	Attaching the pump station	M 6	1680
F2	Attaching the pump station	M 6	1520

Total volume:	757 l
Immersed DHW tank volume:	568 l
Fluid volume in Thermal Store:	174 l
Heat exchanger (HX) volume:	15 l
Heat exchanger surface area:	2,5 sqm
Max. working temp. in thermal store:	95 °C
Max. working temperature in heat exchanger:	95 °C
Max. working temperature in DHW tank:	95 °C
Max. working pressure in DHW tank:	3 bar
Max. working pressure in thermal store:	6 bar
Max. working pressure in HX:	10 bar
Empty weight:	176 kg
Electric heating element (Accessories):	type ETT-C, F, M, P
Number and max. length of heating element:	3 x 635 mm

Regulus DUO 1000/200 N PR Thermal Store (code: 19149, insulation - code: 19329)

Dimensions

Tipping height without insulation 2120 mm

CONNECTIONS

pos.	descriptions	connection	height [mm]
Heat sources			
B1	Incoming from heat source	G 6/4" F	1115
B2	Return to heat source	G 6/4" F	200
B3	Incoming from heat source	G 6/4" F	1700
B4	Return to heat source	G 6/4" F	1220
B5	Incoming from heat source	G 1" F	1635
B6	Incoming from heat source	G 6/4" F	785
Heating system			
H1	Outlet to the heating circuit	G 1" F	1160
H2	Return from the heating circuit	G 1" F	290
Solar system			
X1	Incoming from solar collectors	G 1" F	950
X2	Return to solar collectors	G 1" F	300
Electric heating elements			
E1	Electric heating element for space heating	G 6/4" F	1020
E2	Electric heating element for space heating	G 6/4" F	1020
E3	Electric heating element for DHW heating	G 6/4" F	1310
DHW heating			
W1	Cold water	G 3/4" M	2080
W2	Hot water	G 3/4" M	2080
W3	Recirculation	G 3/4" M	2080
A1	Anode	G 3/4" F	2025
Control and safety			
C1	Temperature sensor – space heating	G 1/2" F	1130
C2	Temperature sensor – solar	G 1/2" F	740
C3	Temperature sensor – DHW heating	G 1/2" F	1440
C4	Temperature sensor – DHW heating	G 1/2" F	1350
T	Thermometer	G 1/2" F	1700
M	Pressure gauge	G 1/2" F	510
P	Safety valve	G 1/2" F	400
Air release			
O	Air vent valve	G 1/2" F	2055
Other			
F1	Attaching the pump station	M 6	1725
F2	Attaching the pump station	M 6	1565

Total volume:	903 l
Immersed DHW tank volume:	711 l
Fluid volume in Thermal Store:	174 l
Heat exchanger (HX) volume:	18 l
Heat exchanger surface area:	3,2 sqm
Max. working temp. in thermal store:	95 °C
Max. working temperature in heat exchanger:	95 °C
Max. working temperature in DHW tank:	95 °C
Max. working pressure in DHW tank:	3 bar
Max. working pressure in thermal store:	6 bar
Max. working pressure in HX:	10 bar
Empty weight:	195 kg
Electric heating element (Accessories)::	type ETT-C, F, M, P
Number and max. length of heating element:	3 x 700 mm

Regulus DUO 1700/200 N PR Thermal Store (code: 19145, insulation - code: 19357)

Dimensions

Tipping height without insulation 2200 mm

Ø 1300
Ø 1100
2080

15°
100
125
100
250
250
30°
45°
30°
45°

CONNECTIONS

pos.	descriptions	connection	height [mm]
Heat sources			
B1	Incoming from heat source	G 6/4" F	1150
B2	Return to heat source	G 6/4" F	235
B3	Incoming from heat source	G 6/4" F	1675
B4	Return to heat source	G 6/4" F	1255
B5	Incoming from heat source	G 1" F	1610
B6	Incoming from heat source	G 6/4" F	820
Heating system			
H1	Outlet to the heating circuit	G 1" F	1195
H2	Return from the heating circuit	G 1" F	325
Solar system			
X1	Incoming from solar collectors	G 1" F	935
X2	Return to solar collectors	G 1" F	335
Electric heating elements			
E1	Electric heating element for space heating	G 6/4" F	1055
E2	Electric heating element for space heating	G 6/4" F	1055
E3	Electric heating element for DHW heating	G 6/4" F	1295
DHW heating			
W1	Cold water	G 3/4" M	2080
W2	Hot water	G 3/4" M	2080
W3	Recirculation	G 3/4" M	2080
A1	Anode	G 3/4" F	2025
Control and safety			
C1	Temperature sensor – space heating	G 1/2" F	1165
C2	Temperature sensor – solar	G 1/2" F	775
C3	Temperature sensor – DHW heating	G 1/2" F	1425
C4	Temperature sensor – DHW heating	G 1/2" F	1335
T	Thermometer	G 1/2" F	1675
M	Pressure gauge	G 1/2" F	510
P	Safety valve	G 1/2" F	400
Air release			
O	Air vent valve	G 1/2" F	2055
Other			
F1	Attaching the pump station	M 6	1700
F2	Attaching the pump station	M 6	1540

Total volume:	1682 l
Immersed DHW tank volume:	1486 l
Fluid volume in Thermal Store:	174 l
Heat exchanger (HX) volume:	22 l
Heat exchanger surface area:	4,0 sqm
Max. working temp. in thermal store:	95 °C
Max. working temperature in heat exchanger:	95 °C
Max. working temperature in DHW tank:	95 °C
Max. working pressure in DHW tank:	3 bar
Max. working pressure in thermal store:	6 bar
Max. working pressure in HX:	10 bar
Empty weight:	268 kg
Electric heating element (Accessories):	type ETT-C, F, M, P
Number and max. length of heating element:	3 x 955 mm

4 - Operation

This tank is designed to accumulate thermal energy in household or industrial applications, however always in sealed pressure circuits with forced circulation.

Hot water is heated by heating water inside the integrated DHW tank. It connects with fittings to both cold and hot water piping, possibly also to a hot water recirculation circuit. When hot water is drawn from an outlet point, cold water flows into the immersed DHW tank and heats up from the heating water in the thermal store to a temperature set by the thermostat placed in the sheath of the DHW tank, or in a heating system controller. Hot water temperature should be set to 60-65 °C. This temperature guarantees the best operation and at the same time, it prevents formation of Legionella bacteria.

5 - Typical Layout Example with Thermal Store

Hydraulic variant : Solar set with heat pump combined with electric heating elements and fireplace

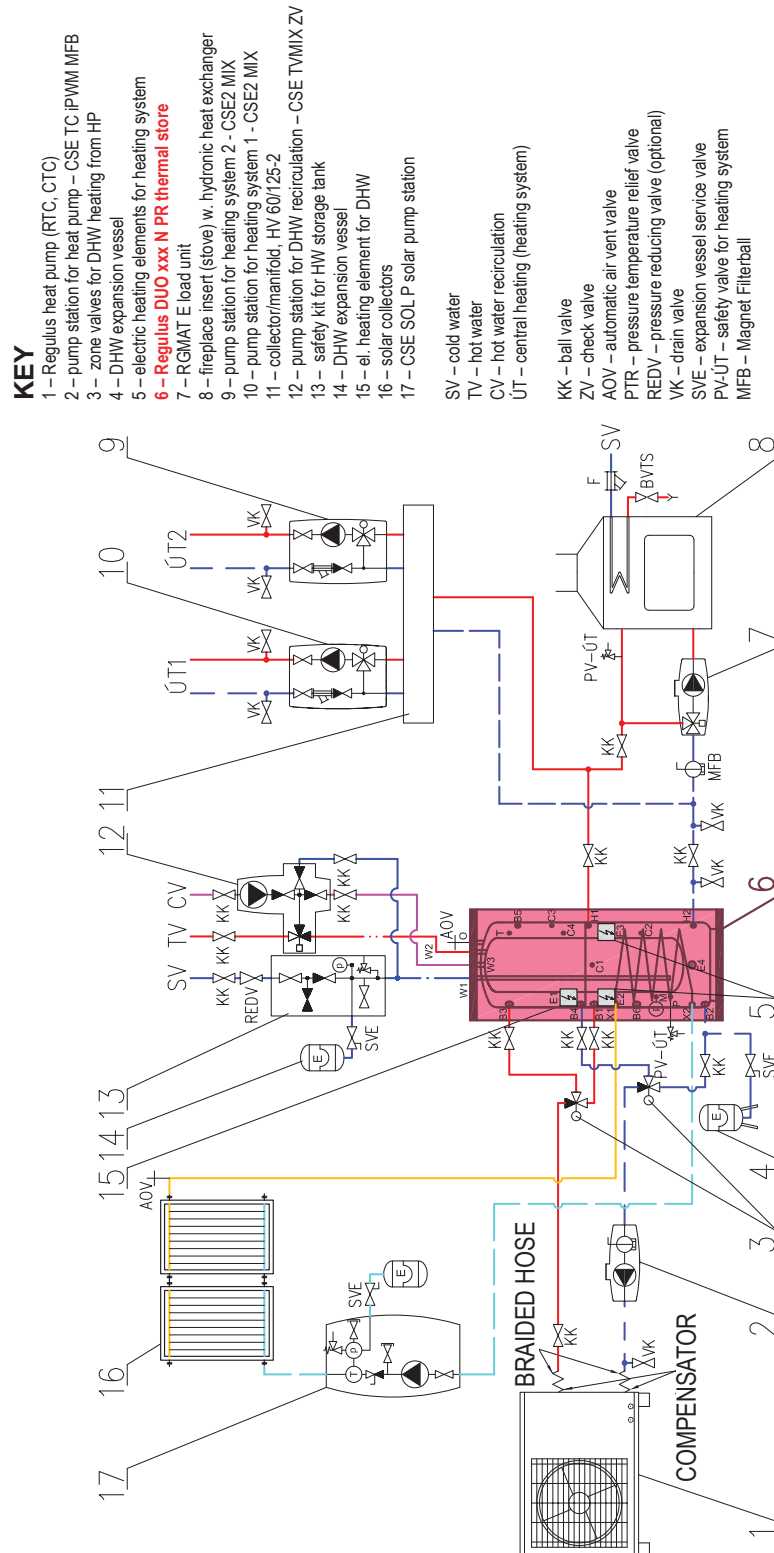

6 - Installation and Commissioning

Installation shall meet valid rules and may be done by qualified staff only.

Installation of an el. heating rod may be done by qualified staff only.

Defects caused by improper installation, use or handling are not covered by warranty.

After the tank is installed and connected to an existing heating system, it is recommended to clean the entire heating system using a suitable cleaning agent, e.g. BP 400. Anti-corrosion protective liquid should be also used, e.g. BP 100 Plus.

6.1 - Connection to heat sources

Place the tank on the floor, as close to your heat source as possible and level it. Connect the heating system according to one of the schematic diagrams - see Chap. 5. Install a drain valve at the lowest point of the tank. Install an air vent valve at the highest point of the system. Insulate all the connection piping.

6.2 - Connection to a solar thermal system

The tank can be used with a solar system. In such a case, the inlet for hot heat-carrying liquid coming from the solar thermal system shall be connected to the G 1" upper sleeve of the heating coil. The lower G 1" heating coil outlet shall be connected to the return solar piping through which cooled solar fluid returns to solar collectors. Insulate meticulously all the piping between the tank and the solar thermal system.

6.3 - Heating element installation

Electric heating elements shall be installed into G 6/4" side connections. They can be connected either directly (elements with integrated thermostat) or via the controller of the entire heating system. Electric heating elements shall be wired by a professionally qualified person only.

Warning: All electric heating elements shall be protected by a safety thermostat.

6.4 - Connection to water mains

DHW piping shall be done according to valid rules. The connection to the tank, including the fittings, is shown in the diagram of the recommended connections in Chap. 5. Installation of a pressure reducing valve on the immersed tank inlet is recommended. For water mains pressure above 6 bar a pressure reducing valve is necessary. To prevent water loss, we recommend installing an expansion vessel at the cold water inlet to the immersed tank with a minimum volume of 4% of the total volume of water in the DHW piping, including heat exchangers, recirculation pipes, etc. (usually 8 l). Installation of an expansion vessel is one of the necessary conditions for the extended warranty. Should the water be too hard, install a water softener upstream of the tank. In case the water source contains mechanical impurities, install a filter.

Table of limit values for total dissolved solids in hot water.

Description	pH	Total dissolved solids (TDS)	Ca	Chlorides	Mg	Na	Fe
Max. value	6.5 - 9.5	600 mg/l	40 mg/l	100 mg/l	20 mg/l	200 mg/l	0,2 mg/l

6.5 - Commissioning

Ground the tank before commissioning.

During commissioning, the immersed hot water tank shall be filled and pressurized first, after that the thermal store can be filled. If the thermal store was filled first, the DHW tank would get damaged!!!

The tank shall be filled up together with the heating system, respecting valid standards and rules. In order to minimize corrosion, special additives for heating systems should be used. The quality of heating water depends on the quality of filling water at commissioning, on the top-up water and on the frequency of topping up. This has a strong influence on the lifetime of heating systems. Poor quality of heating water may cause problems like corrosion or incrustation, esp. on heat transfer surfaces.

Quality of DHW shall meet the conditions shown in the Table of limit values for total dissolved solids in hot water in Chap. 6.4. of this Manual.

Fill the heating system with the appropriate fluids and air-bleed the entire system. Check all connections for leaks and verify the system pressure. Set the heating controller in compliance with the documentation and manufacturer's recommendations. Check regularly the proper function of all control and adjustment elements.

7 - Installing Insulation on the Tank

Product description

Thermal insulation is a part of thermal stores, preventing heat loss. For easier handling, the insulation shall not be fitted on the tank until it reaches its definite place of installation.

Warning

Insulation installation shall be done in two persons. Do not use any tools for installation. Keep away from open fire.

Installing Insulation

1. Fix the tank following installation instructions.
2. Wrap the insulation around the tank carefully. Check that the insulation adheres to its body perfectly. This can be reached by rubbing and patting the insulation by hand from its center evenly in both directions until the insulation adheres to the tank's surface completely and no bubbles are left.
3. Use the holes for connections as a rest during the insulation installation.
4. At least one person presses the insulation to the tank, pulling both ends together. The other person closes the insulation lock from the side.
5. Put on the upper insulation and cover.
6. Push on the covering plastic rosettes depending on the size of connections.
7. Finish the tank installation in compliance with the respective instructions and valid standards and rules.

Warranty on insulation

- Warranty shall become null and void if:
 - the procedure described in the Installation Manual was not respected
 - the product was used for other purposes than intended.
- Warranty does not cover:
 - usual wear and tear,
 - damage caused by fire, water, electricity or a natural disaster,
 - defects caused by failure to use the product in compliance with its intended purpose, by improper use and insufficient maintenance,
 - defects caused by mechanical damage to the product,
 - defects caused by tampering or incompetent repair.

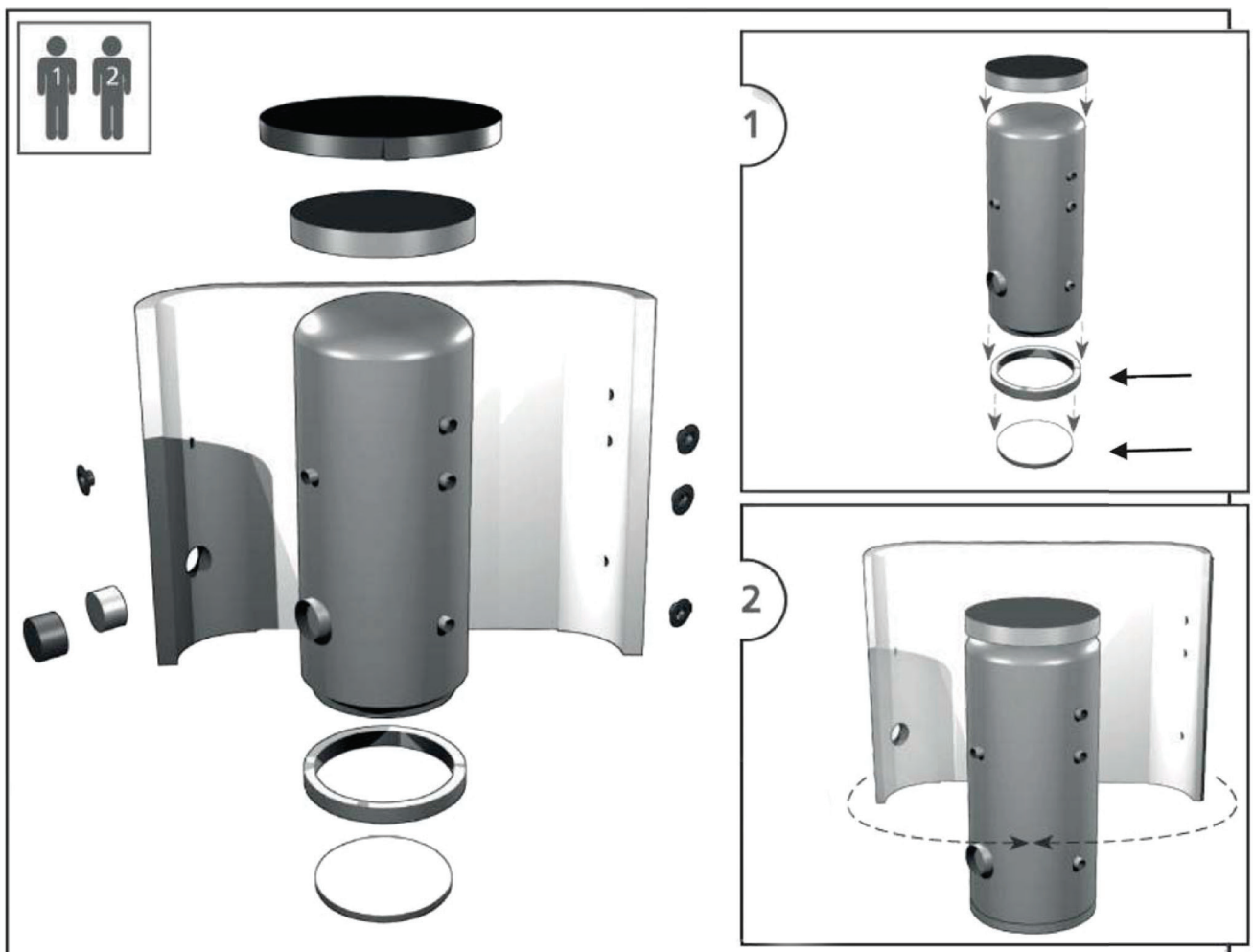

8 - Maintenance

If the tank is fitted with a heating element, disconnect it from the mains first. Clean the exterior of the tank with a soft cloth and a mild detergent. Never use abrasive cleaners or solvents.

Check all connections for leaks.

The thermal stores come with an anti-corrosion sacrifice magnesium anode rod as standard. The condition of the anode rod shall be checked within 12 months after commissioning and subsequently always not later than 12 months after the last check. In locations where water contains more ferrites or calcites, it is recommended to check the anode rod every 6 months. If more than one third of its total volume is consumed, the anode rod shall be replaced with a new one. Disregarded of its state, the magnesium anode rod shall be always replaced with a new one within 24 months from commissioning.

In order to replace a magnesium anode rod, decrease the pressure inside the Thermal Store to the atmospheric value first, then the pressure inside the hot water tank. Replace the anode rod and pressurize the inner hot water tank first, then pressurize the Thermal Store.

If damage to a tank occurs due to the neglected substitution or a wrong replacement procedure of a magnesium anode rod, the warranty cannot be claimed.

9 - Disposal

Packaging shall be disposed of in compliance with the valid rules. When the product reaches the end of its life, it shall not be disposed of as household waste. It shall be dropped off at a Local Waste Recycling Center. Insulation shall be recycled as plastic and the steel vessel as scrap iron.

10 - Warranty

This product is covered by warranty according to the conditions described in this Manual and according to the Warranty Certificate. A Warranty Certificate forms an integral part of the supply. Tank transport or storing in a horizontal position is considered a warranty violation!